



ELECTRICAL COMMUNICATION

July 1939

Volume 18, Number 1



ELECTRICAL COMMUNICATION

A Journal of Progress in the
Telephone, Telegraph and Radio Art

H. T. KOHLHAAS, EDITOR

EDITORIAL BOARD

E. A. Brofos G. Deakin E. M. Deloraine P. E. Erikson F. Gill
W. Hatton R. A. Mack H. M. Pease Kenneth E. Stockton C. E. Strong

Issued Quarterly by the

International Standard Electric Corporation

67 BROAD STREET, NEW YORK, N.Y., U.S.A.

Volume XVIII

July, 1939

Number 1

	PAGE
DEVELOPMENT ASPECTS OF INTERNATIONAL VOICE FREQUENCY SIGNALING AND DIALING UNDER CONSIDERATION BY THE C.C.I.F. <i>By E. P. G. Wright</i>	3
FUNDAMENTAL TRANSMISSION PLANNING OF TELEPHONE NETWORKS.. <i>By Bruce H. McCurdy</i>	25
CALCULATION OF TRIODE CONSTANTS..... <i>By J. H. Fremlin</i>	33
A NEW HARD VALVE RELAXATION OSCILLATOR..... <i>By D. H. Black</i>	50
NEW "SPOT WAVE" SERIES OF COMMERCIAL RADIO TRANSMITTERS..	57
RECTIFIER POWER PLANT FOR TRANSMISSION SYSTEMS..... <i>By R. Kelly</i>	60
TIE LINE PROBLEMS IN P.A.B.X. DESIGN..... <i>By R. T. Ringjob</i>	65
EXPERIMENTAL RESEARCHES ON THE PROPAGATION OF ELECTROMAGNETIC WAVES IN DIELECTRIC (CYLINDRICAL) GUIDES..... <i>By A. G. Clavier and V. Altovsky</i>	81
TELEPHONE AND TELEGRAPH STATISTICS OF THE WORLD.....	106
RECENT TELECOMMUNICATION DEVELOPMENTS OF INTEREST.....	111



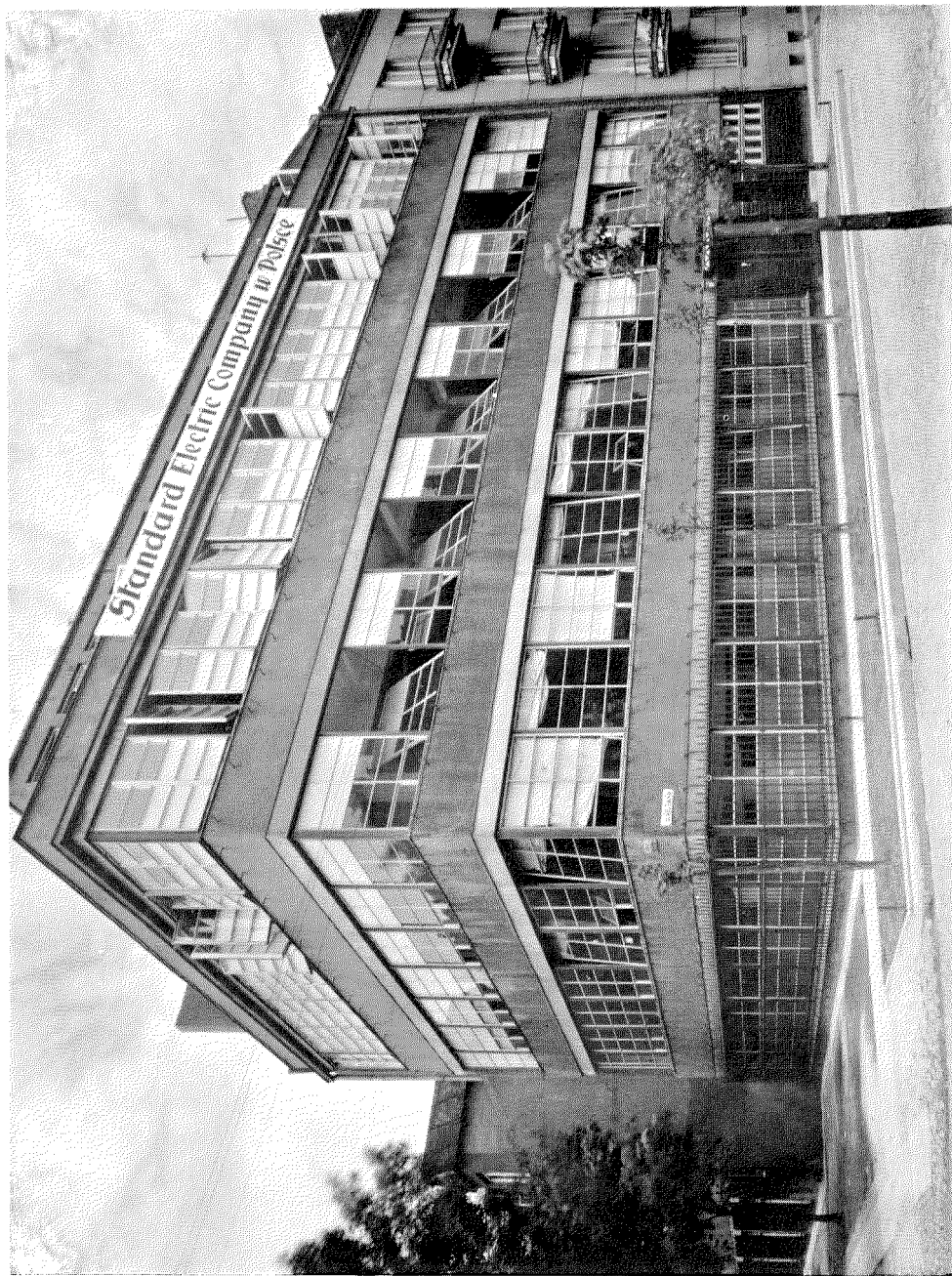

Standard Electric Company w Polsee Factory in Warsaw, Poland.

Development Aspects of International Voice Frequency Signalling and Dialling under Consideration by the C.C.I.F.

By E. P. G. WRIGHT, M.I.E.E.,

Standard Telephones and Cables, Limited, London, England

CONTENTS

- | | |
|--|---|
| 1. <i>Introduction.</i> | 10. <i>Efficiency of the Guard Circuit.</i> |
| 2. <i>Importance and Necessity of Voice Frequency Signalling.</i> | 11. <i>Considerations controlling the General Arrangement of the Voice Frequency Code of Signals.</i> |
| 3. <i>Comparison with D.C. and other A.C. Signalling Systems.</i> | 12. <i>Signal Code Timing.</i> |
| 4. <i>Interference between Voice Frequency Systems.</i> | 13. <i>Transit Working.</i> |
| 5. <i>Recommendations to avoid Interference between Voice Frequency Systems.</i> | 14. <i>Summary of Research Work in Progress and Questions awaiting consideration.</i> |
| 6. <i>Time Variations associated with Voice Frequency Signals.</i> | <i>Appendix No. 1—Glossary of Terms.</i> |
| 7. <i>Choice of Frequency for the Prefix Signal.</i> | <i>Appendix No. 2—Translation of Proceedings of 3rd Commission of Rapporteurs, Oslo, June 1938.</i> |
| 8. <i>Voice Immunity Tests.</i> | <i>Bibliography.</i> |
| 9. <i>Determination of Length of Prefix.</i> | |

I. INTRODUCTION

ADDED interest in the development of systems of voice frequency signalling and dialling is resulting from study being devoted to this subject by the C.C.I.F. It is in connection with work of this nature, involving the danger of interferences, that the assistance of the C.C.I.F. is of immense value. Each National Administration is naturally capable of choosing the most advantageous arrangement for the national conditions concerned, but it is only by general discussion between representatives from different Administrations with different conditions to fulfil that recommendations can be framed for guiding the subsequent development, so that problems which might otherwise arise are avoided.

The immediate objective of the Sub-Committee of the C.C.I.F. established to investigate voice frequency signalling problems is to

recommend the basic principles to be used to indicate the conditions to be met by voice frequency receivers and to establish the safeguards which are necessary to avoid interference between national systems when connected together by international circuits.

Several excellent descriptions of the principles underlying the development of voice frequency systems of signalling and dialling are available in published papers; it therefore seems desirable largely to avoid descriptive details. Diagrams and descriptions of the circuits of the receiver and associated relays are omitted because the examination of such details is thought to be of less interest than the circumstances which control the design basically. The recommendations of the C.C.I.F., 3rd C.R., already issued, constituting the specification to which the receivers on international lines should be constructed in respect to power, attenuation,

frequency variation, insertion loss, temperature change, voltage change, etc., are included for reference purposes (see Appendix No. 2) but are not discussed.

Great emphasis is laid on the dangers of interference to voice frequency circuits from various different sources because this aspect of the subject has not been explained thoroughly elsewhere. It is hoped that this article will be of assistance as an explanation of the reasons why alternative arrangements, which may appear at first sight to be simpler or cheaper, are considered to be less satisfactory.

2. IMPORTANCE AND NECESSITY OF VOICE FREQUENCY SIGNALLING

The statistical reports issued from time to time show the rate at which long distance telephony has expanded in recent years. Prior to the development of the technique for transmitting speech between cities, countries and finally continents, practically without regard to distance, an actual demand existed for such facilities and, in consequence, Telephone Administrations have hastened plant extension programmes for the introduction, and for the rapid increase in most cases, of the long line equipment.

Although modern technique can provide a standard of speech transmission on long distance circuits leaving little to be desired, the signalling on the majority of these circuits is relatively crude, resulting in the Administration failing to realize the full earning power of the lines and the subscriber failing to receive the speed of service to which he is entitled.

It is the primary function of voice frequency signalling to provide the quick and accurate interchange of information which is essential to an efficient service. The purpose of voice frequency dialling is to speed up still further the time required for connection and release. The establishment of quicker connections and signalling on long distance circuits calls for a re-examination of the existing national and international switching plans because the new economic conditions are different from the old. The time taken by two or three operators to set up a call bears little relation to the time taken by a single operator dialling the complete connection, and an even more marked contrast

is displayed by the time necessary for the release of the connection. Operator dialling has been responsible for increasing the traffic load by as much as 15 per cent. to 20 per cent. and such an improvement causes a considerable reduction in the waiting time, with the result that the number of calls is increased. With an efficient switching plan the number of switching points for the average connection can be increased; thus different groups of traffic can be combined and a further saving in the line plant effected.

The value of the long line plant is high in comparison with that of voice frequency signalling and dialling equipment, and a small saving in line time can justify considerable additional signalling plant. The reliability of the long line equipment is of great importance. For these reasons voice frequency systems are judged chiefly by their speed and reliability.

The fundamental reason for the use of voice frequency currents for the transmission of signals and dial impulses lies in the fact that these currents will pass over the speech channel without the necessity for any special arrangements to pass the signals through or around the speech repeaters which may be present in toll lines. The ability of the voice frequency currents to pass from end to end of the built-up connection provides the possibility of extending the impulsing circuit stage by stage to avoid the distortion which is inherent in impulse repetition.

3. COMPARISON WITH D.C. AND OTHER A.C. SIGNALLING SYSTEMS

On circuits local to an exchange and on those employed for short inter-exchange connections, experience shows that D.C. circuits provide the cheapest and most satisfactory service. Advantage is taken of the use of continuous current to indicate changes of condition. For use on longer circuits, A.C. currents may be employed in conditions for which D.C. would be impracticable owing to the absence of physical conductors or the limitations imposed on the impulsing relays by extreme conditions of resistance and capacity of the line. The A.C. may be in, above, or below the voice frequency range. In the case of the lower frequencies, such as 50-150 p : s, speech currents cause no

interference, while the use of high pass filters in the line does not affect speech and yet serves the double purpose of preventing the leakage of signalling current and the entry of extraneous currents of low frequency.

In such systems changes of condition are signalled by impulses of current. A relatively high signal power is used and the impulses are retransmitted at each line termination and at intermediate repeater stations.

D.C. and low frequency A.C. systems have the advantage that the condensers or filters which restrict the signals to a section of the line prevent interference between sections, but such systems are not readily applicable to carrier operation. An approximate equivalent to a D.C. carrier signalling system is provided by transmitting the carrier and interrupting the current for signalling purposes. Such an arrangement offers the possibility of signalling without interference but transmission complications are involved. Carrier systems have inadequate power handling capacity for low frequency signals which cannot always be transmitted satisfactorily owing to the high attenuation encountered.

Systems using frequencies such as 2 500–3 000 p : s have the advantage that the power necessary can be readily transmitted and that the interference currents from speech are of very low power. Retransmission of signals at repeater stations is unnecessary, but end-to-end signalling tends to be unreliable due to the variation of attenuation at these frequencies. The use of low pass filters to avoid interference between sections is not permissible on account of the impairment to speech. As these frequencies are not transmitted in the case of many loaded cables and some carrier systems, their application is likely to be severely restricted.

4. INTERFERENCE BETWEEN VOICE FREQUENCY SYSTEMS

Voice frequency systems are much more subject to interference than D.C. or low frequency A.C. systems. Apart from interference attributable to speech or echo suppressors, there is that due to mutual interference between separate voice frequency systems. All sections of a connection must be capable of passing voice frequencies and, therefore, even when

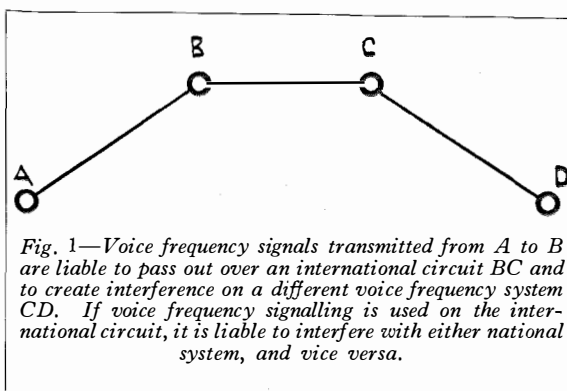

Fig. 1—Voice frequency signals transmitted from A to B are liable to pass out over an international circuit BC and to create interference on a different voice frequency system CD. If voice frequency signalling is used on the international circuit, it is liable to interfere with either national system, and vice versa.

intermediate sections are not using voice frequency signalling, there is the possibility of interference between systems normally quite independent. For example, on international connections there is the possibility of mutual interference between different national voice frequency systems and also of interference between the national system and that used for signalling over the international lines. To restrict the signals to a portion of the connection is fundamentally difficult because voice frequency currents cannot be adequately filtered without impairment to articulation (Fig. 1).

It is evident that some international agreement is necessary on the fundamental principles of design to ensure that, when two national systems are connected together by any type of international line, the pulses of voice frequency current used for signalling in one national system are prevented from passing out over the international line to the other national system in such a way as to cause false signals on either the international or the distant national system. As it is unreasonable to assume that the signals which are required on national circuits will be identical to those necessary for international circuits, the agreed fundamental principles for avoiding mutual interference should cater for the possibility that the national systems are not identical with the international system.

5. RECOMMENDATIONS TO AVOID INTERFERENCE BETWEEN VOICE FREQUENCY SYSTEMS

National Administrations look to the C.C.I.F. for recommendations as to the best method of avoiding interference in difficulties of this type. At the meeting held in Copenhagen

in 1936 a recommendation was made as to the frequencies to be used for voice frequency signalling over international circuits. At the meeting held in Oslo in 1938 a special Sub-Committee of the 3rd Commission of Rapporteurs was appointed for the study of voice frequency signalling matters, and a translation of the recommendations made as the result of the Oslo meeting appears in Appendix No. 2.

Perhaps the most important principle established is that interference can be avoided if each national system is designed to be capable of preventing signals exceeding a certain duration from passing out beyond the national system and, conversely, that signals of a shorter duration have no significance and, therefore, are incapable of causing interference within the national system.

The Sub - Committee recommend that an adequate control of voice frequency signals be obtained by the use of a prefix before the transmission of all signals which are liable to pass beyond the national boundary. The function of this prefix should be, firstly, that of splitting the line at a switching point in such a way as to prevent more than the permissible amount of the signal from passing beyond that switching point and, secondly, that of preparing the circuit to admit the subsequent receipt of a suffix signal. This principle of operation necessitates general agreement as to the line splitting time which corresponds to the maximum duration of the current passing beyond the splitting point. (The factors influencing the duration of the splitting time are detailed in Section 6.) It is important, therefore, that voice frequency signalling systems be designed to be non-responsive to short pulses of either signalling frequency.

6. TIME VARIATIONS ASSOCIATED WITH VOICE FREQUENCY SIGNALS

In D.C. signalling systems a change of condition is indicated by a change of potential or a change in the direction of current. It is usually possible for the circuit to be arranged for simultaneous signalling in both directions and, so long as it is wished to maintain the indication at the remote end of the circuit, it is possible to maintain the change of D.C. condition.

With A.C. signalling, continuous signals cannot easily be applied during speech conditions and it is, therefore, more difficult to maintain simultaneous signalling in both directions, particularly on lines fitted with echo suppressors designed to prevent currents passing in both directions simultaneously. For this reason most A.C. signalling systems rely on the use of a series of impulses varying in duration or frequency. A response to these impulses can readily be obtained by the operation or release of relays, but the timing of these relays is subject to inherent variations due to adjustment and voltage margins. Furthermore, the reception of the voice frequency impulses will also be subject to variations due to line attenuation, frequency shift and the tuning of the receiving elements.

When a number of voice frequency receivers are attached on the same connection without end-to-end signalling, it is necessary that only the adjacent receiver respond to each signal; otherwise confusion may be introduced by receivers responding to "foreign" signals, especially when the same signal is used with different significance as the connection proceeds. In order to ensure correct operation some timing control is necessary. This control must take into account the fact that interference on the line due to speech or tone may curtail the transmitted signal in such a way that its duration, as received, may be any portion of the complete signal.

The principle of the control employed restricts the signalling currents to portions of the complete connection in a way similar to the division of a D.C. circuit by means of condensers. It is not practical to introduce filters to act as rejectors but it is possible to open or split the line at switching points adjacent to each voice frequency receiver. This splitting of the connection is produced by the signalling currents and, therefore, is not analogous to the case of filters, owing to the delay factor before the isolation is effected. If a signal of some predetermined time is arranged to open the line, then it follows that no impulse exceeding this period is capable of passing over the line beyond the switching point. Therefore, if it is arranged that all the significant signals are longer than the maximum splitting impulse,

the resulting effect is limited to the adjacent receiver which remains connected to the line after the splitting function has taken place. In order to guarantee that the maximum amount of current passing out of the system should not be exceeded, when adjustments and conditions are on maximum limits, splitting must have occurred at the termination of the specified duration; when adjustments and conditions are on minimum limits, splitting occurs before the predetermined maximum period.

The function of the splitting relay is limited to opening the line beyond the receiver and subsequently reclosing the line. A second relay is necessary for checking the duration of the prefix signal.

Similar timing variations apply to the prefix responding relay; and not only must the transmitted impulse be sufficient to cover this variation but, in addition, an allowance must be made for the transmission variations and the possibility that preceding voice currents on the line may have left the receivers in an insensitive condition, either because a signal may commence while tone is on the line or because the signal may follow a series of capacity discharges due to a subscriber entering or leaving the connection. In such circumstances there may be present on the line voice frequency currents which operate a guard circuit in the receiver and, until these currents have died down and the guard circuit has restored to normal, the signal response is liable to be impaired.

It is naturally desirable to make the signalling as rapid as possible. If investigation of receiver immunity from speech interference indicates that the minimum splitting impulse permissible is 90 ms., an allowance of approximately 45 ms. is necessary for time variations of the receiving relay which may be adjusted to respond at 90 ms. minimum, 135 ms. maximum, after the commencement of the receipt of the signal. Such a margin is desirable for the maintenance of this relay.

On the basis of these figures, the minimum response time for the recognition of the signal prefix may be fixed at 150 ms. The prefix response relay requires a variation of 70 ms., giving a maximum release time of 220 ms. The transmitted impulse provides a margin of a further 30 or 40 ms. for losses due to generation,

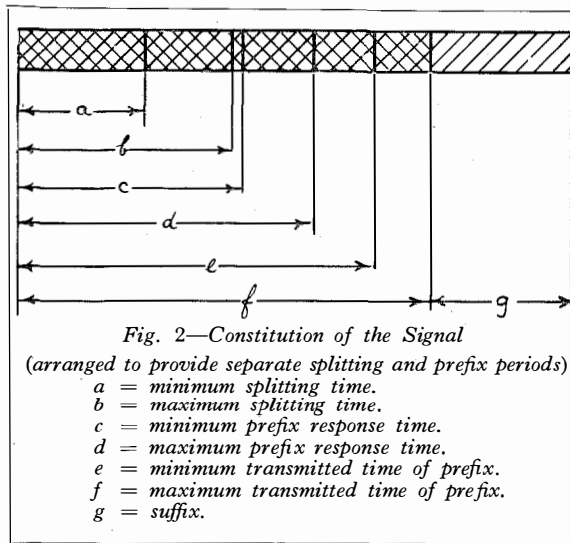

transmission and preceding disturbances, so that the minimum basic signal builds up to approximately 260 ms., which is about three times the duration of the minimum splitting time. Any increase in the minimum splitting time requires a proportional increase in the length of the signal transmitted as a prefix (Fig. 2).

7. CHOICE OF FREQUENCY FOR THE PREFIX SIGNAL

7.A. The Complete Function and Application of the Prefix Signal

The prefix plays such an important part in the built-up connection that it is desirable to outline its complete function and application before dealing with its constitution. It may appear contradictory that in a system using voice frequency currents there are advantages to be gained by dialling and signalling from end to end and yet means are necessary to prevent the signals and dial impulses from passing from end to end. The reason is apparent in considering that a national network may be built up on a uniform code of signals and that, whenever two voice frequency circuits are joined together, the impulsing and signalling are extended without retransmission. Such a system is likely to be capable of connection to international lines leading to another national network following the same principles but using a larger or smaller code of signals. If these two signalling codes do not coincide, an adequate separation has to

be effected. The separation applies to the signals transmitted from any terminal. The receiver connected at the incoming end of a circuit can be arranged to use the prefix for splitting purposes to effect separation or, alternatively, to allow the prefix to pass without splitting the line.

The function of the prefix, as its name implies, is preparatory. Owing to the fact that voice frequency signals pass from one end of a built-up connection to the other end, the prefix indicates that a signal is being transmitted and that it has significance to the particular receiver which accepts the signal. At the time when the prefix is accepted and recognized, the line is split beyond the receiver and at the transmitting end it is also split before the signal is commenced. In these circumstances the two receivers are connected together free from any external interference and sensitive to the suffix portion of the signal, which can be short and of a single frequency frequently present in speech. The exact arrangement of the suffix portion of the signal is described in greater detail later.

7.B. Frequencies Available

Mention has previously been made of the recommendation of the C.C.I.F. on the frequencies to be used for signalling and dialling. Following this recommendation, which is to use the frequencies 600 and 750 p/s, it is possible to choose a single frequency for the prefix or a compound signal of the two frequencies transmitted simultaneously. A third possibility is the use of the frequencies alternately. This last possibility appears to introduce too much complication in timing if a number of components are used whereas, with two components only, it has little merit in comparison with the single frequency prefix in view of the difficulty of instantaneous switchover from one frequency to the other or the limitations imposed if a space component separates the frequencies.

7.C. Speech Immunity

It has been found that the compound prefix is preferable to the single frequencies for the following two reasons: Firstly, the compound

frequency prefix permits a greater number of signals of each character or duration; secondly, the greater immunity of the compound prefix from speech interference permits the use of a shorter prefix and, therefore, of quicker signalling.

7.D. Response Characteristics

The response of the receiver to a compound frequency signal is slower than the response to a single frequency signal, owing to the division of available power between the two portions of the circuit. For the dial impulses a quicker response is desirable because less distortion is likely with a quick response; but, for the larger splitting signal, an accurate time response is not so important, especially if the transmitted length of the signal has a reasonable margin over and above the maximum response time. There are advantages, therefore, in the use of a compound frequency signal for the prefix, with a single frequency for dial impulses.

7.E. Number of Signals Available

In considering the number of signals available, it appears that a compound prefix may be followed by a suffix formed by either of the single frequencies or by a compound frequency, and that a single frequency prefix may also be followed by either of the single frequencies or by a compound frequency suffix, making three signals available in either case.

There is, however, a danger that distant-end speech or the action of splitting may react on the receiver in such a way that the last portion of the prefix signal becomes detached from the earlier portion, so that, in effect, a broken prefix is received as a prefix and suffix. This possibility is greatest with adverse factors in the incoming receiver consisting of splitting time high, prefix time low, receiver response time high, space component low, suffix time low. This danger of misconstruction makes it inadvisable to use a suffix signal of the same composition but shorter than a prefix signal.

As previously stated, the response time is liable to greater variation with a compound frequency signal than with a single frequency signal. Consequently, if the compound component is being used to form a part of the whole

signal, it is more suitable for the long prefix than as a short suffix or for dial impulses.

The simple arrangement of prefix and suffix is, therefore, restricted to a compound prefix followed by either of the single frequencies used for the suffix, or one single frequency for the prefix followed by the other for the suffix. With the single frequency prefix a second signal can be obtained by reversing the frequencies and arranging a relay circuit to perform a double discrimination on prefix and suffix, but such an arrangement is restricted to the use of one single frequency in the forward direction, and the second for the return, since it is inadvisable to double the danger of speech interference by the use of two separate prefix frequencies, although compensation could be introduced by a further extension of the length of the signals. Moreover, it is possible, with a relay circuit designed to make double discrimination of frequencies used in sequence, to obtain six separate signals from a suffix formed of two impulses following a compound prefix.

The prefix alone is unsuitable for important signals because of the danger that other signals may be mutilated, not necessarily by speech, while safeguards to avoid this trouble slow down the speed of signalling. Before the possibility of speech connection necessitates the use of any prefix, short and long single frequency signals are available in a compound prefix system without the danger that a prefix signal may be misconstrued.

7.F. Other Considerations

There is no evidence that a receiver designed for compound frequency signals introduces complexity.

7.G. Conclusion

For the above reasons, it is desirable to use a compound signal component for the prefix and single frequency components for dial pulses.

8. VOICE IMMUNITY TESTS

As already explained, the use of voice frequency currents for signalling and dialling systems is not based on the particular suitability of these currents for the purpose but rather on their suitability to the transmission char-

acteristics of the long distance channels which are designed only for currents in the voice frequency diapason. The A.C. signalling systems using frequencies outside the speech band avoid certain of the difficulties experienced with voice frequency systems, but are subject to other difficulties. In systems restricted to the voice frequency range there is an inherent liability to interference from speech or tones. Precautions are necessary for the following possibilities :

- 8.A. Distortion to dialling from near-end speech or noises picked up and transmitted by the microphone of the calling party.
- 8.B. False splitting due to the presence of signal frequencies in speech.
- 8.C. Failure to split correctly due to part of the signal being neutralized by transitory currents causing operation of some guard circuits only, resulting in response to "foreign" signals.

Research work shows that the signal currents produced in speech are rarely pure but are usually accompanied by harmonics and sub-harmonics. Although the signal currents may be sufficient to cause the operation of a relay corresponding to a signal frequency, it is still possible to avoid any result from this operation by adding a guarding element which is tuned to respond to a wide band of non-signal frequencies. Operation of this guarding element may disable the contacts of the signalling relay or act as an electrical bias serving to make more difficult the operation of the relay responding to the signalling frequency. These guard circuits introduce the further possibility of interference (Fig. 3).

- 8.D. Inability to accept correct signals due to operation of guard circuit from speech or line noise.

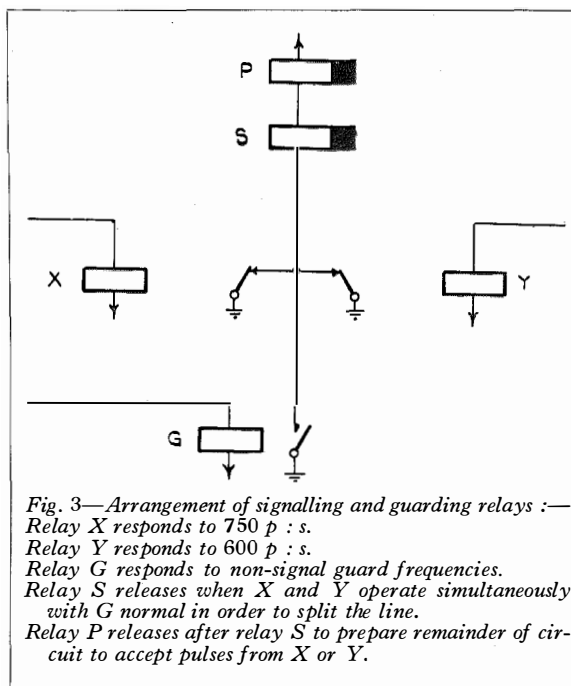

Fig. 3—Arrangement of signalling and guarding relays :—
 Relay X responds to 750 p : s.
 Relay Y responds to 600 p : s.
 Relay G responds to non-signal guard frequencies.
 Relay S releases when X and Y operate simultaneously with G normal in order to split the line.
 Relay P releases after relay S to prepare remainder of circuit to accept pulses from X or Y.

Bearing these possibilities in mind, it is evident that the immunity of the voice frequency system from interference is a primary condition to be taken into account in the design of the receiver and the arrangement of the signalling code. An investigation of the duration and combination of frequencies in speech can be carried out only by sampling the speech of a large number of individuals speaking over circuits with differing conditions. It is essential that a voice frequency system be universally applicable; that is, complete immunity from false operation must be provided for every individual.

The earliest immunity tests carried out showed spasmodic interference. For several days the circuit on test would operate without interference, and then in a short space of time a relatively large number of interferences occurred. It was observed that more faults were found when languages other than English were used. A rough comparison of immunity showed that the single frequencies were subject

to approximately ten times the interference observed with combined frequencies. Further tests carried out on the Continent showed similar results but with a somewhat greater advantage in favour of the combined signals.

In 1938 an elaborate immunity test was carried out in London with a number of receivers of different types connected to the same circuit. These tests were designed for the primary purpose of determining whether the use of combined frequencies provides a system less liable to speech interference than one utilizing single frequencies when an equal time delay is employed or, alternatively, a system having the same immunity from speech operation with a smaller time delay. The secondary object of the test was to check the splitting time proposed at the C.C.I.F. meeting at Oslo, and, in addition, it was anticipated that valuable design information could be obtained.

At first sight it would appear self-evident that a receiver responsive to simultaneous frequencies inherently possesses greater inter-

TABLE I
VOICE IMMUNITY TEST IN ENGLISH, FRENCH AND GERMAN
Comparison between Single and Compound Prefix Signals.

X Receivers measured to record X (750 p : s).
Y " " " Y (600 p : s).
XY " " " X and Y simultaneously.

Table represents false splits due to speech per 100 speech hours.

Receivers designed to split line open between	48/52 ms.	96/104 ms.	144/156 ms.	192/208 ms.	240/260 ms.	288/312 ms.	Duration of Test in Speech Hours
Level 10 X	5 803	2 263	539	199	94	49	} 350
Y	7 862	2 122	623	279	135	67	
XY	100	11	3	2	1	1	
Level Zero X	4 663	1 487	516	217	91	58	} 640
Y	4 084	920	304	105	51	37	
XY	21	3	1	1	0	0	
Level — 10 X	1 736	431	129	47	23	16	} 350
Y	1 189	242	74	28	11	5	
XY	9	1	1	0	0	0	
Level — 18 X	414	104	30	8	3	1	} 400
Y	242	33	6	5	1	0	
XY	0	0	0	0	0	0	

NOTE 1.—This comparative test is not representative of actual false splitting because the hybrid coils used to attenuate near-end interference were disconnected.

NOTE 2.—These measurements are made on a single group of receivers designed for use with a sending power of 1 mW of each frequency into 600 ohms measured as a steady frequency. Separate anode relays for X and Y provide means of measurement singly or in combination. There are obvious difficulties in achieving the ideal condition of equal power for single and compound signals.

TABLE II

VOICE IMMUNITY TEST IN ENGLISH, FRENCH AND GERMAN

Comparison between individual receivers to show variation.

X Receivers measured to record X (750 p : s).
 Y " " " Y (600 p : s).
 XY " " " X and Y simultaneously.

Table represents false splits due to speech per 100 speech hours.

Receivers designed to split line open between	48/52 ms.	96/104 ms.	144/156 ms.	192/208 ms.	240/260 ms.	288/312 ms.	Duration of Test in Speech Hours
Level + 10							
X1	2 610	720	158	80	38	6	50
X2	4 160	946	310	118	58	31	50
X3	2 452	550	154	56	26	6	50
X4	10 448	3 234	926	248	130	72	50
Y1	4 426	934	266	96	42	18	50
Y2	14 432	3 418	962	366	182	72	50
Y3	1 860	498	162	66	34	12	50
Y4	9 850	2 270	542	270	90	52	50
XY1	40	6	0	0	0	0	50
XY2	92	12	2	0	0	0	50
XY3	12	0	0	0	0	0	50
XY4	172	8	4	0	0	0	50

NOTE 1.—These measurements were made simultaneously on 50 hours of speech.

NOTE 2.—This comparative test is not representative of actual false splitting because the hybrid coils used to attenuate near-end interference were disconnected.

NOTE 3.—These receivers were protected from speech by guard relays operating on non-signal frequencies and by the use of voltage limiting devices.

ference immunity than a receiver requiring only one frequency. It is known also that other considerations associated with the receiver design prevent an ideal response.

The test receivers were subjected to the requirements of a stringent specification inasmuch as it is apparent that a receiver may be made very immune from speech if it has no other functions to perform. For example, an over-efficient guard circuit may be employed, accepting all frequencies other than those used for signalling. Furthermore, the guard circuit may be coupled with a delay of such magnitude that during speech the guard elements remain operated continuously. Both these conditions, however, must be controlled; otherwise it may become impossible to signal in the presence of speech or tones.

The conditions for dialling are also important because the least distortion possible is desirable for the dial impulses; and, if the same frequency is used for prefix purposes, the receiver cannot easily be given the best adjustment to suit both conditions simultaneously.

The results of these tests confirm the preference for the combined prefix, as compared with the single prefix, showing a reduction in interference lying between 90 per cent. and 99 per cent., depending on the performance of different receivers and measurements made at different levels with different languages (Table I).

One of the most important observations was the variation between receivers of the same design operating on the same circuit and at the same relative level, although all these receivers were accurately adjusted and check-tested from time to time (Table II).

The observations indicate that a 5 : 1 variation is not unusual in a relatively small group of receivers, and a much wider variation is probable between factory-produced receivers subjected to normal routine processes, so that the immunity to be expected in practice is likely to be worse than that found during test. There was an indication that each design of receiver has a characteristic response to the variation of level, but the response was not consistent for different designs of receiver and, again, greater interfer-

ence was experienced with languages other than English. As these tests were carried out in London, it is reasonable to assume that in many cases the language used was foreign to the listener and that, with the desire to avoid misunderstanding, the voice was raised unconsciously, possibly accounting for the greater interference.

9. DETERMINATION OF LENGTH OF PREFIX

The immunity from interference and the speed of signalling are the two fundamental factors influencing the time of response to, and therefore the length of, the prefix signal. For the former, the prefix should be as long as possible, while for the latter it should be as short as possible.

The presence in speech of signal frequencies for a sufficient duration results, first of all, in a splitting operation. If the signal frequencies are maintained for a longer period, they may be mistaken for a prefix signal, in which case the receiver in effect becomes more sensitive and there is then liability of a false signal being received.

False splitting may mutilate speech to an extent slightly worse than that experienced with echo suppressors when a listener fails to

break in during a conversation and a number of syllables or words are lost and the meaning of the sentence destroyed. Many statements representing questions or replies have a duration of only 200 or 300 ms., and such sentences may be totally lost on account of echo suppressors. The chief difference between echo suppressor losses and false splitting operations is that, with the former, the answering party is aware of the interruption and consequently is prepared to repeat the statement, whereas, with false splitting, the interference may remove a syllable or two from a statement during a period when the listening party knows that there has been no speech interruption; for example, the words "90 pounds" may be received as "9 pounds" if the line is split for approximately 50 ms. It is, therefore, important that false splitting operations be avoided.

False signals may cause an operator to challenge on the line or to make the circuit noisy, due to the operation of the speaking key or the direct reaction from splitting the line. Such conditions could be tolerated, say, once in every 250 hours, but false signals of a particular type may result in the call being released and cannot be tolerated in normal circumstances. The liability to a false signal involves the combination of a false prefix and a false

TABLE III

VOICE IMMUNITY TEST IN ENGLISH, FRENCH AND GERMAN

Comparison between guard circuits on compound prefix signals.

A — Receivers arranged with voltage limiting device.

B — Receivers also employing non-signal frequency guard relays.

Table represents false splits due to speech per 100 speech hours.

Receivers designed to split line open between	48/52 ms.	96/104 ms.	144/156 ms.	192/208 ms.	240/260 ms.	288/312 ms.	Duration of Test in Speech Hours
Level + 10 <i>A</i>	389	49	10	4	2	0	} 350
<i>B</i>	100	11	3	2	1	0	
Level Zero <i>A</i>	88	10	3	2	0	0	} 800
<i>B</i>	39	4	1	1	0	0	
Level — 10 <i>A</i>	42	4	1	1	0	0	} 500
<i>B</i>	22	3	1	1	0	0	
Level — 18 <i>A</i>	0	0	0	0	0	0	} 400
<i>B</i>	0	0	0	0	0	0	

NOTE.—This comparative test is not representative of actual false splitting because the hybrid coils used to attenuate near-end interference were disconnected.

suffix, and it seems probable that the determination of the minimum splitting time depends chiefly on the liability to false splitting. On the basis of observations made, 80-100 ms. seems to represent a reasonable splitting time, and this figure provides a tolerable margin for the receiving relay, ensuring that the maximum splitting time never exceeds the 150 ms. recommended by the C.C.I.F. for compound prefix signals (Table IV).

TABLE IV

VOICE IMMUNITY TESTS IN ENGLISH AND GERMAN
Result of False Speech Operations

With Comparisons between Different Signals.

Interference per 1 000 hours circuit time at + 5 db. level.

Four receivers each tested on 680 hours occupied time, during which voice currents were measured for approximately 320 hours.

	Faults
False Splitting $\overline{X} \dots \overline{Y}$	18.75
False Prefix $\overline{X} \overline{Y}$	7.5
False Signal \overline{XX}	1.5
False Signal $\overline{X} \overline{SX}$	0.35
False Signal \overline{XY}	1.65
False Signal $\overline{X} \overline{SY}$	0.35

X = 750 p : s ; Y = 600 p : s ; S = Space 20 - 100 ms.

One other consideration which requires attention in the arrangement of the prefix is the possibility that the relays timing the reception of the signal may become operated by a succession of short pulses of signal frequency in speech, the cumulative effect of which is equivalent to a longer pulse. This type of trouble can be avoided almost entirely by the use of relays in the guard circuit operating in the first detected space to reject the interrupted signals entirely. The relay responding to the prefix signal should be rapidly reset to its nominal timing after operation, otherwise there is the danger that the receiver is in an over-sensitive condition immediately after receiving the prefix portion of the signal only.

10. EFFICIENCY OF THE GUARD CIRCUIT

Protection from false signals due to the presence of signalling frequency currents occurring in speech is obtained usually by voltage

limiting devices and circuits depending on non-signalling frequency, electrically or mechanically neutralizing any operation of the signal frequencies. The effect of these devices is further increased by delaying their restoration to the normal condition. It follows quite naturally that any attempt to signal while speech or tones are present on the line may be abortive due to the operation of the guard circuit. If signals are to be transmitted in these circumstances, they must be prolonged or repeated to permit them to be received at a time when there is a pause in the speech or tone. On this account it is undesirable for the guard circuit to operate with a time lag which would tend to bridge such pauses. For exactly the same reasons it is necessary that a maximum power level be established for the non-operation or release of the guard circuit to ensure that it does not remain operated due to room or line noises.

Experience shows that speech at a relatively high level may maintain operated continuously for 4 or 5 seconds a guard circuit of normal sensitivity adjusted to enable at least seventy impulses out of a hundred to be received in the presence of speech.

Inequality of the guard circuits is also a source of trouble, due to operation from "foreign" signals ; for example, a voice frequency signalling circuit AB is connected by a 500/20 p : s ringing circuit BC to a second voice frequency signalling circuit CD. If the guard circuit at B operates on all non-signal frequencies, whereas the receivers at C and D are only incapacitated by non-signal frequencies below 500 p : s, interference is likely because a 500 p : s current may prevent splitting and prefix recognition at B, so that a signal from A reaches D. The acknowledgment signal is normally prevented from passing back beyond C, meanwhile A is repeating the signal to B. In spite of the difficulty of regulating the efficiency of the guard circuit, it seems desirable that the C.C.I.F. consider and recommend what course should be followed.

11. CONSIDERATIONS CONTROLLING THE GENERAL ARRANGEMENT OF THE VOICE FREQUENCY CODE OF SIGNALS (TABLE V)

As mentioned in Section 8, there are a number of interference sources which are liable

to interfere with dialling and signalling, due to the presence of speech or tones on the line. The construction of a code of signals necessitates examination of these disturbances due to speech and, also, some record is required of the extraneous conditions which are liable to impair the integrity and stability of the signals.

11.A. Disturbance to Impulsing

Possible sources of interference, in order of importance, are :—

- 11.A (1). Disturbance in the D.C. circuit, including the dial, upsetting the receiver at the distant end of the toll line. As the disturbances take place before any operation of the D.C. circuit, it is very difficult to protect the receiver by opening or short-circuiting the line at the outgoing end sufficiently early to avoid a discharge from the first impulse. A similar type of trouble may arise at the incoming end due to capacity discharges in the D.C. circuit reacting on the incoming voice frequency receiver. This disturbance is to be expected, not only on the first impulse but subsequently at the time of switching from one selector to another in a step-by-step system.
- 11.A (2). Liability of all sounds to which a microphone is sensitive being transmitted from the caller's telephone during the inter-digital pauses. If these currents are of the signalling frequency, false dial impulses may be recorded and retransmitted by the voice frequency receiver. If the currents are of guard frequency, the receiver is rendered insensitive until the guard circuit is restored ; thus impulses may be mutilated.
- 11.A (3). To render an accurate response to impulsing, the incoming receiver is designed to operate from quite short pulses of the impulsing frequency which are known to occur frequently in speech. To avoid the creation of false impulses during speech, the incoming receiver needs to be insensitive to such pulses as soon as the dialling is completed.
- 11.A (4). A troublesome type of interference involves dialling over a built-up connection including two separate V.F. portions. If there is a normal forward speech path, the dial impulses on the first portion will also be operative on the incoming receiver of the second portion and possibly also on the outgoing receiver of the second portion.

11.B. Possible Methods of Impulsing

There are two methods of approach to these difficulties. Either the path for forward speech is not connected through until dialling is complete or, conversely, the speech path is normally connected with the receivers in an insensitive condition until the operations resulting from dialling create changes in conditions to sensitize the receivers. In either case the backward speech path may be maintained for the transmission of tones indicating the condition of the connection. Systems providing a distinctive end-of-selection signal can be arranged to disconnect the dialling circuit and to connect the forward speech at the end of selection. In other systems, one of the following methods may be applied :—

11.B (1). Speech path connected through on restoration of the dialling key independently of any answer signal.

11.B (2). Answer signal provided on all calls with no forward speech before answer.

11.B (3). Tone- or speech-operated signal to switch through forward speech.

11.B (4). Counting number of digits passing to control switching of forward speech path.

11.B (5). Regeneration of impulses, with or without prefix signal, before each train of dial impulses.

Considering these possibilities in greater detail :—

- 11.B (1). Dial key control is simple and circuit arrangements can be made to pass a suitable signal forward over a D.C. circuit even if the operator is dialling from an exchange other than that at which the toll line terminates. This type of control is, however, quite unsuitable for subscriber dialling owing to the absence of any signal when dialling is completed and the introduction of a new signal must be avoided. The dial key control method needs, in addition, some signal to the incoming receiver to transfer it into a speech condition (See 11.A (3)). There is also difficulty if a connection necessitates two-voice frequency sections without end-to-end signalling owing to the difficulty of passing forward the dial key control to the second section.
- 11.B (2). The universal answer signal introduces the difficulty that all calls must be metered before any speech can commence. This is not a serious matter on long distance calls for which there is an operator available to prepare a suitable ticket. It is more serious on local calls because, if the connection is not completed, credit must be established for every uncompleted call. Over the V.F. circuit there is no difficulty in transmitting a special answer signal which does not result in metering, but the D.C. terminations have no means for transmitting such a signal. Difficulty is also experienced in systems which include 50 p : s and 150 p : s A.C. signalling circuits which may be arranged to pass the proceed-to-dial, end-of-selection and answer signals without being capable of differentiating one from another. On such a connection no information is conveyed to an intermediate V.F. section as to which is the answer signal and, in consequence, no switching operation is possible. To summarize, the use of a blocking valve to prevent forward speech is an effective cure to the troubles, but it introduces difficulty of its own in being dependent on an answering signal which may not be convenient, especially on international circuits.
- 11.B (3). The tone- or speech-operated device must respond to low level speech and must not respond to any line noises encountered before the dialling is completed. The arrangement would be inoperative in the case of the receiver being lifted immediately and no speech following. The receivers at the incoming end of the line must include a similar device to terminate the dialling condition (See 11.A (3)). Again the blocking valve is an effective cure. The arrangement depends on a mechanically responsive guard circuit which will switch through the speech path. The arrangement is possibly more suited to national than international use, because in the former case there is more definite control of the tones which are likely to be encountered during the dialling process.
- 11.B (4). Counting the number of digits transmitted is

a possible solution in simple systems, but the procedure becomes very complicated in mixed digit numbering systems unless the principle can be applied as a means of identifying an end-of-selection signal. In such circumstances there is no need to discriminate between the value of the digits but only to record whether more than one train of impulses passes in response to a proceed-to-dial signal.

11.B (5). Impulse regenerators offer some interesting possibilities in connection with voice frequency dialling. These regenerators function to store and retransmit impulses. Because the incoming impulses may vary in speed, it is usual for the regenerators to make a small delay before commencing to send a digit which is being received. This principle makes it possible to prepare the outgoing end of the line for impulsing and permits the incoming receiver to settle down after any disturbance which may be caused at the commencement of the first impulse. In a similar way the regenerator at the incoming end may be used to disassociate the D.C. portion of the circuit and, in consequence, prevent the condenser discharge from reacting on the incoming receiver. In subscriber dialling systems the use of a prefix before each digit is a most convenient method of avoiding the use of signals to arrange the speech condition. With this arrangement the circuits are normally in the speech condition and are completed for the dialling condition temporarily. This technique requires the storage of impulses at the outgoing end which is adequately accomplished by a regenerator. The disadvantage of the regenerator method is the delay period introduced before sending the first digit, but such a delay is encountered frequently on register and other systems.

11.C. The Answer Signal

The second main problem concerns the safeguarding of the answer signal. Occasional subscribers are notoriously ingenious in finding methods of avoiding payment so that, for subscriber dialling systems, it is essential to preclude the possibility of a short answering signal being lost due to the transmission of additional digits or shouting on the line. Systems depending on the answering signal for switching through the forward path are immune from speech and line noises but there is the possibility of dialling interference or the creation of signals by switch-hook flashing. Other systems are free from the interference due to subsequent dialling owing to an arrangement which will release the connection in these circumstances. An answer signal which is long enough to exceed in duration subscriber-produced interference is undesirable because of the delay introduced before the commencement of conversation.

Probably the most satisfactory method of safeguarding the answer signal is to repeat the signal until it is acknowledged by a combination of frequency which the subscriber cannot produce by manipulation because the splitting technique prevents the subscriber from blocking the answer signal and subsequently transmitting the answer acknowledgment.

It is found by experiments, carried out to investigate the delay in response after the ringing current is cut off by the closure of the D.C. path when the called party answers, that response in less than 1.75 seconds is unusual and that the inability to commence forward speech for such a period is not noticeable to either party. Any delay beyond 3 seconds is liable to cut off the first forward syllables, whereas, with a delay exceeding 5 seconds, there is a danger of the called party abandoning the call. The answer signal with acknowledgment needs 1.25 seconds approximately. If the voice frequency signals are being retransmitted at transit exchanges, each additional circuit needs only 0.5 second because the retransmission is concurrent with the first acknowledgment signal.

11.D. Clearing and Release Signal

It is necessary that the arrangements to be adopted for releasing the voice frequency line

TABLE V

TYPICAL V.F. SIGNALLING CODE WITH AUXILIARY SIGNALS

Signal	Indication in Direction →	Indication in Direction ←
X	Seize	
Y	Test Busy	Proceed-to-Dial
$\frac{X}{Y}$ $\frac{X}{Y}$	(R) Forward Transfer or (R) Offering, Break-down and Ring Forward	(R) Answer (Meter) (R) Ring Back
$\frac{X}{Y}$ $\frac{Y}{Y}$	Acknowledge * Clear Forward	Acknowledge * Clear Back (R) End-of-Selection (R) or Answer (Non-meter)
$\frac{X}{Y}$ $\frac{Y}{Y}$		Release

NOTES.

- 1.—X = 750 p : s, Y = 600 p : s, $\frac{X}{Y}$ = compound 600 and 750 p : s.
- 2.—(R) represents signals repeated until acknowledged.
- 3.—* represents repeated signals.
- 4.—Dial impulses use X (750 p : s) frequency.

SIGNAL TIMING :

- 1.—Prefix length : 250–280 ms.
- 2.—Signal length : 60–70 ms. Release : 250–280 ms.
- 3.—Interval between repetitions : 550 min. incoming.
650 min. outgoing.
- 4.—Interval prefix and signal : 33 ms.

ensure that the two ends release simultaneously and definitely. The presence of an intermediate echo suppressor may interfere with a single signal unless it is of very long duration. There is danger also that the guard circuit of the incoming receiver may be operated while the signal is arriving, and in such circumstances there is naturally the danger of interference.

The layout of the system may be such that the release is under the control of an operator at the incoming end of the toll line, and in such circumstances complete release from a signal in the forward direction is undesirable. If the connection has been extended by an operator at the incoming end by means of a cord and plug, it may not be permissible to release the toll line until the operator has removed the plug from the jack. A single forward impulse release signal must then be followed by a backward signal, to maintain the line engaged at the outgoing end until it becomes free at the incoming end.

An indication of the length of the forward impulse necessary to break through interference can be judged from the fact that approximately 50 per cent. of line talk spurts which do not exceed 6 seconds duration are estimated to be without sufficient pause to permit an echo suppressor to release. The most frequent pause in speech has a duration between 200 and 400 ms. and an echo suppressor may absorb a pause of less duration.

Tests comparing the relative immunity of short and long signals to speech interference indicate that with a very sensitive guard circuit speech currents may prevent more than 5 per cent. of signals having a duration of 300 ms. from being received, whereas the receivers accept at least a 300 ms. portion of 50 per cent. of signals with 2 seconds duration, and with the signal extended to 6 seconds, 99 per cent. succeed in providing a signal exceeding 300 ms. to the incoming receiver. There is evidence to show that the guard circuit should, in practice, be much less sensitive and permit approximately 70 per cent. of the 300 ms. signals to be accepted. With a guard circuit of this efficiency some 98 per cent. of the 2-second signals are safely received, provided there is no loss due to echo suppressors which should be considered as a separate source of interference when present. The operation of a normal echo suppressor will

block a line in one direction and, so long as the echo suppressor remains operated, no voice frequency signal can be transmitted in the direction suppressed.

On circuits in which intermediate echo suppressors are unavoidably present, interference can be restricted by admitting some measure of delay.

11.D (a). By repeating the signals until they are acknowledged, preferably with an arrangement by which transmission is delayed if the guard relay is operated due to the presence of guard frequencies.

11.D (b). By repeating the signals when the reception of other tones at the transmitting end indicates a probability that the signal path is not open.

11.D (c). By delaying the transmission of signals if the reception of other tones at the transmitting end indicates a probability that the signal path is not open.

Using the method which depends on the repetition and acknowledgment of signals, it is necessary to hold the transmitting end of the line open until the acknowledgment is received, in order to ensure that the echo suppressor is not maintained operated by extraneous currents mutilating the acknowledgment. It is also necessary to ensure that the acknowledgment signal is not transmitted until a sufficient period has elapsed to cover the hangover time of the echo suppressor. These two requirements do not introduce difficulty.

The detector required for the second method must necessarily be more sensitive than the echo suppressor, yet not sufficiently sensitive to operate in response to noise. This requirement appears to set very close limits on the detector because the margin between the noise level and the sensitivity of the echo suppressor is frequently small.

There is also the possible danger that the echo suppressor may operate undetected after the commencement of transmission but before the receipt of the signal. As with the acknowledgment method, it is also necessary to ensure that the signal is not transmitted until sufficient time has elapsed to cover the hangover time of the echo suppressor. It is, therefore, desirable to employ a repetition method in all cases of lines with intermediate echo suppressors. Terminal echo suppressors situated at transit points become intermediate echo suppressors when lines are switched through.

The difficulties encountered with echo suppressor interference are allied to those due to

the operation of the guard relay in the voice frequency receiver.

For lines of all types a uniform principle of release is obtained by a forward clearing signal repeated periodically until a backward release signal has been received. This arrangement avoids the use of continuous backward signals and maintains the line available for re-ring and forward supervision signals.

It is very desirable that the ultimate release signal should be different in character from other signals inasmuch as the design of the transit receiver circuit is more simply arranged to recognize such a condition rather than the combination of certain signals in each direction.

11.E. Proceed-to-Dial Signal

In many systems it is desirable to include a proceed-to-dial signal to indicate when a register or connecting circuit is attached at the incoming end. This proceed-to-dial signal is valuable also on both-way circuits on which the risk of call collisions is serious due to the use of toll board circuits which indicate to the operator immediately a toll line becomes available. It is possible by means of the proceed-to-dial signal and a simple circuit addition to give a preference, for example, to the call coming from the direction of the national toll centre, the other call being connected to busy tone.

11.F. Clear-Back Signal

The clear-back supervision when the called party flashes can be given either by a signal on hanging up and another signal on lifting the receiver again, or by sending a succession of signals while the receiver is on the rest. The latter method is preferred owing to the possibility of interference by speech and the consequent complication and slowing-up of signalling if any method of acknowledgment is adopted.

At first sight it would appear to be possible to allow the clear-back signal to take the form of a prefix followed by a succession of suffix signals, but such a signal would be dependent on the safe reception of the initial prefix and would jeopardize the possibility of inserting a forward re-ring signal owing to the delays introduced between receiving and transmitting to

provide time for the receiver response, propagation time and echo suppressors, as described later. If the suffix signals are spread out, there remains no advantage in comparison with the repeated signal without acknowledgment.

12. SIGNAL CODE TIMING

12.A. Prefix

As indicated in Section 6, the minimum splitting time to guard against speech interference is approximately 80–100 ms. and, to avoid interference between systems, a current duration of not more than 150 ms. is permitted to pass the splitting point. This condition necessitates that the line should be split not later than 150 ms. after the current reaches the splitting point.

If the response time of the receiver is 25 ms. when operating under conditions extreme but liable to occur, then the artificial delay to be provided cannot exceed 125 ms. as a maximum. If the timing element measuring 125 ms. does not itself open the line but closes the circuit for a relay, the operation of which performs this function, then the artificial delay is again reduced to allow for the operating time of this relay. The period elapsing while the timing element is restoring on the cessation of the voice frequency current is also important because this time and the receiver response time have a very direct bearing on the immunity of the system.

If the line is to be split to guarantee that current does not pass out beyond the splitting point for more than 150 ms., it is impossible for a receiver with a response time of 25 ms. to check the maintenance of the current for the whole period of 150 ms. before opening the line; actually the receiver is out of phase and, by the time 150 ms. is measured, 175 ms. of current will have passed out to the line. The minimum length of impulse causing the splitting action is indicated generally by the artificial delay provided. If the artificial delay comprises a relay, then the minimum release or operating time of this relay represents the duration of the impulse which is liable to split the line.

As already mentioned, the prefix reception is timed to fall between 150 ms. and 210 ms. For this circuit the response time losses are not detrimental but there is no reason why the prefix should not be checked for the full period

of 150 ms. when on minimum adjustment. This does not mean that there is any additional margin because the splitting arrangements at an intermediate point may pass a current lasting for the full period of 150 ms. although the line will generally be split before the impulse has reached this duration. The prefix time to be transmitted therefore must exceed the maximum receipt time of 210 ms. and make some allowance for generation variations. It is known that the guard circuit of the receiver is frequently operated during a conversation and it is found that, if the transmitted prefix has a reasonable margin above the receipt time, the receiver has a greater chance of recovery.

For research purposes 43 000 test impulses of 50 ms. duration were connected to a line on which speech was present and to which a number of receivers adjusted to receive impulses of 50 ms. were attached. 18 900 impulses were received. At the same time 43 000 impulses of 120 ms. duration were connected to a line on which the same speech at the same level was present and to which a number of receivers adjusted to accept impulses of 100 ms. were attached. 34 000 impulses were received. This test was repeated with a smaller number of receivers on which the mechanical response to the guard circuit had been disabled. Of 4 000 impulses of 50 ms. duration transmitted with speech on the line to receivers adjusted to accept impulses of 50 ms., 3 988 were received. Of 4 000 impulses of 120 ms. duration transmitted with the same speech on the line to receivers adjusted to accept impulses of 100 ms., 3 987 were received. These figures show a certain loss due to the voltage limiting device in the receiver but a considerably larger loss due to the operation of the guard circuit from non-signal frequencies (Table III).

12.B. Suffix

The C.C.I.F. recommend that the transmitted prefix fall between 250 and 350 ms., providing at least 40 ms. margin above the maximum adjustment time of the receivers.

The length of the suffix signal is fixed between 50 and 100 ms., representing approximately the duration of dial impulses. The circuit conditions are not difficult and a shorter impulse might be satisfactory. The pause between pre-

fix and suffix must be sufficient to be easily recognizable and to permit relay operations to take place. 30 ms. is probably the minimum time which is satisfactory, whereas 50 ms. may be considered as the maximum.

12.C. Release

The suffix portion of the release signal has the same minimum duration as the prefix. The advantage of this longer suffix lies in the simplification made possible in the voice frequency receiving circuit when switched into the transit condition.

Reference will be found in Section 13 to the considerations in favour of switching out voice frequency receivers when a number of circuits are used to build up a connection. Once the switching has taken place, the receivers at the transit points have no further functions to perform until the time of the release. If the release signal is of a different character from the other signals, then it can be recognized without difficulty.

With the use of a signal consisting of a prefix followed by a long suffix, false operation from speech is prevented by the prefix which does not split the line but prepares the circuit for the suffix. Complication is introduced if the transit receivers are expected to recognize the direction of transmission of the release signal and inadequate limits may be obtained if the transit receiver has to release, for example, on 500 ms. of 600 p : s passing in one direction but not to release on 1 000 ms. of the same frequency passing in the other direction. It is equally undesirable that the transit receiver should be called upon to release in response to signals passing in each direction in sequence. Such an arrangement would introduce further timing margins and necessitate providing for all the possible combinations of interference and simultaneous transmission.

12.D. Impulsing

The duration of the dial impulse may be controlled by the other conditions existing for setting up the remaining portions of the connection inasmuch as the voice frequency signals can be transmitted over reasonably wide limits such as a make-to-break ratio of 2 : 1 or 1 : 1.

With the use of impulse regeneration the impulses over the voice frequency portion can be operated on a 1 : 1 basis, although both input and output are on a 2 : 1 basis. In a similar way the input and output can be varied independently and, if the conditions on the voice frequency circuit are outside normal limits, impulsing on a 1 : 1 basis may be found to be preferable.

12.E. Intervals

The C.C.I.F. recommend an interval between repeated signals of 550 ms. minimum. This time is measured from the end of the transmission of the suffix of the first signal to the commencement of the transmission of the prefix of the second signal. It is apparent that the interval is insufficient to receive the whole of a signal in the reverse direction and, therefore, the receiver does not commence to transmit if it detects the beginning of any reverse signal. The period of 550 ms. provides for a number of different delays, many of which are variable.

- 12.E (1). The propagation time in the signal direction.
- 12.E (2). The response time of the receiver accepting the signal.
- 12.E (3). The release time of any relay held operated during the receipt of prefix and suffix.
- 12.E (4). The operation time of relays in preparation for the transmission of acknowledgment.
- 12.E (5). The propagation time in the acknowledgment direction.
- 12.E (6). The response time of the receiver accepting the acknowledgment.
- 12.E (7). The operation time of relays to delay the repetition.

If these operations are not completed within the period of 550 ms., the signal in the reverse direction is lost. On lines equipped with echo suppressors it is necessary to ensure, not only that the reverse signal does not arrive too late, but also that the echo suppressor does not clip the signal to such an extent that the portion received is insufficient to provide the correct change of condition.

The hangover time of the echo suppressor does not necessarily constitute any additional period because it runs concurrently with the time required for items 12.E (2, 3 and 4), and that portion of the propagation time necessary for the signal to pass from the echo suppressor to the receiver and subsequently from the receiver to the echo suppressor. If the sum of these separate periods exceeds the hangover time of the echo suppressor, the latter can be

disregarded but, if the sum with the minimum timings permitted is less, then there is the danger that the echo suppressor will mutilate the reverse direction signal. One method of avoiding this trouble is to extend the prefix by a period which is sufficient to ensure the normal length of the impulse to pass the echo suppressor under all conditions. The increased length, when received, is not detrimental to the acceptance of the signal and the delay introduced is relatively small.

An approximate division of the time available is :—

12.E (1).	Forward propagation time to echo suppressor	150 ms.
	Forward propagation time, echo suppressor to receiver	25 ms.
12.E (2).	Receiver response time	15 ms.
12.E (3).	Signal relay release time	110 ms.
12.E (4).	Signal transmission preparation time	30 ms.
12.E (5).	Reverse propagation time, receiver to echo suppressor	25 ms.
	Reverse propagation time from echo suppressor	150 ms.
12.E (6).	Receiver response time	15 ms.
12.E (7).	Delay relay operations	30 ms.

If the propagation time on the first national system is 25 ms., that on the international circuit may be 125 ms. These figures indicate that there is not a very large margin available, but the trend of development is towards the increased use of carrier transmission with quicker propagation times.

13. TRANSIT WORKING

If a number of voice frequency circuits are switched together it is possible to arrange that the voice frequency receiver at the transit points are in such a condition that they do not respond to any further signals other than the final release signal. Alternatively, the voice frequency receivers at the transit points may be left in circuit, the signals being retransmitted over each section of line.

Each repetition will introduce a source of distortion of impulsing. With the connection switched through, less distortion is to be expected, although the received frequency is liable to some change due to carrier drift, resulting in a small distortion of impulse output from the receiver.

As regards signalling, it is apparent that the retransmission of signals will be slower than

end-to-end signalling because each retransmission will add approximately 500 ms. The chief advantages of retransmission are that :—

- 13.A (1). Terminal echo suppressors cannot be switched into intermediate echo suppressors, which tends to restrict the echo suppressor interference possibilities.
- 13.A (2). Special circuit arrangements are unnecessary to set up the transit condition, although arrangements must be made for transmitting signals over the D.C. path.
- 13.A (3). Independence from line limitation in connection with propagation times, carrier drift, etc.

These advantages are offset by the difficulty of tuning a number of receivers to give an identical response resulting in :—

- 13.B (1). An increased number of false splitting operations due to the larger number of receivers awaiting signals, and
- 13.B (2). Erroneous end-to-end signalling due to failure to split line owing to transitory operation of guard circuits.

There are no clear-cut advantages in favour of either method, but with the use of signals repeated until acknowledged, the inconvenience of the intermediate echo suppressor is eliminated and, in consequence, the difficulty of tuning (see 13.B (1)) becomes the paramount factor. In recommending end-to-end signalling with the use of repeated signals it is apparent that circumstances are likely to arise to justify a degree of separation and retransmission, especially on international connections.

14. SUMMARY OF RESEARCH WORK IN PROGRESS AND QUESTIONS AWAITING CONSIDERATION

The elaborate voice immunity tests which have been undertaken to obtain comparable figures for receivers of the same and different designs present a strong case in favour of the use of a combined prefix signal. The tests provide useful information on the relationship between the duration of false signals and their quantity. Some irregularity is apparent on radio channels, but in other respects the records are consistent. A subsequent series of tests to measure the actual number of false splitting operations is still proceeding. The figures obtained during the last six months indicate the amount of interference to be expected and provide interesting information as to the relative immunity of various arrangements of the suffix portion of the signals.

At the forthcoming meeting of the C.C.I.F.

Permanent Sub-Commission it is expected that a recommendation will be made as to the composition of all the principal signals to be used on international circuits. At the same time it should be possible to outline the auxiliary signals which may be needed from time to time.

A recommendation has already been issued on the impulsing speed and consideration will be given to the impulse ratio, and possibly also to the pause between trains of impulses.

Although it is not possible to investigate in a short time all the difficulties involved in the transmission of voice frequency signals, some consideration will be given to the most desirable methods of ensuring the safe receipt of such fundamental signals as answering and releasing. This investigation will naturally include a study of the influence of echo suppressors.

Recommendations issued subsequent to the Oslo meeting specified the general conditions for the design of voice frequency receivers. A study has been proceeding on the requirements to be recommended for the control of the guard circuit elements. The conditions to be considered include the signal-to-noise ratio under which the guard circuit must be guaranteed to operate and not to operate and the range of guard frequencies.

Finally, the author wishes to acknowledge the valuable suggestions and criticisms offered by a number of his associates, particularly Mr. C. B. V. Neilson, of the Woolwich Laboratories of Standard Telephones and Cables, Limited.

APPENDIX No. 1

V. F. Signalling

(Glossary of Terms)

1. Tone

An audible indication to Subscribers and Operators of conditions such as "busy," "ringing."

The word also refers to the currents conveying these indications.

2. Frequency

An abbreviation for an alternating current or potential having a frequency of so many cycles per second . . . example, X frequency.

3. Signal

A frequency or combination of frequencies transmitted according to a code over the circuit.

4. Seizing Signal

A signal transmitted at the commencement of a call to initiate circuit operation. If the circuit is of both-way type, the signal causes the distant outgoing termination to test busy. (In certain systems it will result in the attachment of registering mechanism.)

NOTE.—For use on omnibus lines, a varying code may be desirable for the signal.

5. Impulsing Signal

A signal carrying the selective information to steer the call in the desired direction.

6. Answer (Meter) Signal

A signal transmitted in a backward direction when the called subscriber answers the call. In certain circumstances this signal may also be sent by an operator.

7. Answer (Non-Meter) Signal

A signal transmitted in a backward direction to make circuit changes when an operator answers during the setting up of a connection ; e.g., to prepare the circuit for speech.

8. Clear-Down Signal

A signal transmitted forward as a result of the calling operator removing the plug from the jack or performing some equivalent action.

9. Clear-Forward Signal

A signal transmitted as a result of the calling subscriber replacing his receiver when the release of the connection may be restrained by a manual hold condition.

10. Release Signal

A signal recognized by the transmitting, receiving and transit receivers to be the final signal of a call. At the cessation of the signal the circuits will become free at all points.

11. End of Selection Signal

A signal which may be transmitted in either direction and can be used to prepare the circuit for speech. (The signal is normally given by a register.)

12. Offering Signal

A forward signal transmitted in face of busy tone to cause the final selector to permit speech access to the required subscriber.

13. Breakdown Signal

A forward signal to cause the release of selectors employed in a previous connection if the called subscriber accepts an offered call.

14. Ring Forward Signal

A forward signal transmitted by an operator to ring the wanted subscriber. For example :—

(a) After offering.

(b) After the called subscriber has replaced his receiver.

15. Ring Back Signal

A backward signal to recall a calling subscriber held by the operator (manual hold).

16. Flashing Signal

A signal from one operator to another or from a subscriber held by an operator.

17. Forward Transfer Signal

A signal forward which may cause the release of selectors to transfer a call to an operator, either directly or by dialling a further digit.

18. Backward Transfer Signal

A signal transmitted in a backward direction by an incoming operator to cause the intervention of an operator at the calling end.

19. Manual Hold

A condition whereby the calling subscriber (or operator) loses the complete control of the connection, so that, in spite of performing the regular clearing function, the line is not released. The distant operator receives a supervisory signal.

20. Clear Back Signal

A signal transmitted in the backward direction, indicating that the called subscriber has replaced the receiver. This signal will be used to indicate a corresponding action on the part of the operator.

21. Proceed-to-Dial Signal

A signal transmitted in a backward direction and which may be used before dialling commences or after a code or codes have already been dialled.

22. Busy Flash Signal

A signal transmitted in a backward direction to operate a supervisory lamp to indicate outlet or subscriber busy.

23. Test Busy Signal

A signal transmitted over a circuit to cause a distant O/G. termination to test busy.

24. Simple Signal

A signal consisting of only one frequency.

25. Compound Signal

A signal in which more than one frequency is transmitted at a time.

26. Signal Component

That part of a signal which continues uniform in character throughout its duration.

(In the case of a multi-component signal, with spaces between current pulses, a space may be regarded as a "space component.")

27. Single Component Signal

A signal consisting of only one component.

28. Multi-Component Signal

A signal consisting of more than one component.

29. Sequence Signal

A signal consisting of more than one component, but in which there is no space component.

30. Acknowledgment Signal

A signal transmitted back solely as a result of the reception of another signal, e.g., Answer Acknowledgment.

31. Repeated Signal

A signal which is repeatedly transmitted as long as the indicated conditions persist.

32. Repeated-Until-Acknowledged Signal

A repeated signal with intervals between transmissions sufficient to permit the reception of an acknowledgment signal. The repeated signal ceases when the acknowledgment is received.

33. Prefix or Prefix Signal

The initial portion of a signal which has the function to prepare or sensitize a circuit for the receipt of a signal.

34. Suffix or Suffix Signal

The significant portion of a signal. It is transmitted immediately after the prefix.

35. Splitting Time

The period measured from the connection of V.F. current to a receiver until the time when the through circuit is opened to avoid possible interference.

36. Receiver Response Time

The period measured from the connection of a V.F. current to a receiver until the time of change of condition of the D.C. circuits associated with the receiver.

(March 22, 1938.)

APPENDIX NO. 2**3rd Commission of Rapporteurs,
Oslo—June 28, 1938**

(Translation)

The following Directive was issued with reference to international circuits, either automatic or semi-automatic, which were liable to use or to be connected to circuits using voice frequency signals :—

To avoid interference in the international service, it is recommended that at the end of impulsing a prefix signal, capable of opening the line after a certain time, should be transmitted before each signal.

The prefix should be as short as possible, difficult to produce by the human voice, and not liable to result in an incorrect signal if it is abbreviated or interrupted. The purpose of the prefix signal is to divide the connection into separate sections without causing any other operation. It is only the suffix transmitted after the prefix which results in other change of conditions to the circuits. It is obvious that interference can result if the frequency, or the combination of frequencies, used for the prefix signal is connected to the international circuits.

It is probable that the use of the prefix composed of a mixture of the two frequencies (600 and 750 p : s) will provide the greatest protection against operation by interfering currents. However, the use of this type of signal may introduce additional complexity into the V.F. receiver, so that, before making a definite choice, Administrations are recommended to study and make tests to enable them to obtain more experience of systems utilizing both compound signals and simple signals.

Signals

It is recommended that the fundamental signals should be separated from the auxiliary signals. The following are the fundamental and auxiliary signals :—

Fundamental Signals

- (1) Seizing signal.
- (2) Dialed impulses.
- (3) Answer signal.
- (4) Clear-back signal.
- (5) Release signal.

Auxiliary Signals, for example :—

- (1) Forward transfer signal.
- (2) Offering signal.
- (3) Breakdown signal.
- (4) Ring forward signal.

Constitution of the Signals

- (1) Seizing signal—a single short impulse of 750 p : s.
- (2) Dialed impulses—impulses of 750 p : s.
- (3) Answer signal—prefix followed by a short signal of 750 p : s (see remark under “Release Signal”).
- (4) Clear-back signal—prefix and suffix of 600 p : s. This signal is repeated complete. The interval between signals should be greater than 550 ms. The signal continues until release or until the called party returns to the line.
- (5) Release signal—there are two cases to consider :—
 - (a) In certain cases the release signal is sent forward from the caller to the called. It is made up of the prefix followed by a long suffix of 600 p : s.
 - (b) In other cases, a forward signal comprising a prefix followed by a short suffix of 600 p : s. This signal results in the transmission of a release signal which is sent in the backward direction. The release signal is made up of a prefix followed by a long suffix of 600 p : s (see the note below).

Important Note

Arrangements should be made to guarantee that all signals are received with certainty.

Auxiliary Signals

The Directive will be issued later.

Signal Length

Short Signal

60–100 ms.

Long Signal

300–400 ms.

Compound Prefix

250–350 ms.

Single Frequency Prefix

To be fixed later.

Pause between Prefix and Suffix

30–50 ms.

Repeated Signals

The pause between two consecutive signals should be equal to, or greater than, 550 ms.

Receiver Specification

Limits for Signal Frequencies

The admissible variation for the generation of signal frequencies on international circuits should be ± 0.5 per cent. The receiver should function with a relatively uniform response over a band of ± 22.5 p : s from the nominal frequency in order to provide for variations at the source and change of frequency due to a carrier shift.

Limits for the Power which may be used

(1) *Single Frequency*

2 mW with a variation of ± 1 db., measured at the point of zero relative level and measured as a steady frequency.

(2) *Compound Frequencies*

1 mW of each frequency, measured at the point of zero relative level, with a termination of 600 ohms, and measured as a steady frequency with a variation of ± 1 db., provided that the voltage of the two frequencies does not differ by more than 0.5 db. or 0.05 neper.

Dialed Impulses

It is desirable to standardize the impinging speed for international circuits. 10 ± 1 p : s is recommended. It is also recommended that the impulse ratio should be standardized on international circuits, but it is not possible to fix this ratio actually.

Insertion Loss

The insertion loss of the voice frequency receiver should not exceed 0.035 neper for any frequency transmitted by the circuit.

Receiver Operating Limits

The receiver should be designed for connection to a point of nominal relative level of from 0–1.2 neper and should operate correctly when the actual relative level differs from the nominal relative level by ± 0.5 neper.

General

In order to prevent a two-frequency circuit being indicated free at an outgoing end before

the circuit is free at the distant end, the principle of release should maintain the circuit indicated busy at all points of access until it is actually available at all points.

Tones

The following tones are considered for international circuits :—

- (1) Dialling tone.
- (2) and (3) Busy tone: (2) Local busy tone; (3) Toll busy tone.
- (4) Number unobtainable tone.
- (5) Ringing tone.
- (1) It is not possible, on international circuits using echo-suppressors, to use a continuous tone for the dial tone. The transmission of a signal of very short duration only is possible. It is desirable to recommend that no dial tone should be transmitted in the near future. For the time being, a very short tone will be admissible.
- (2) and (3) It is desirable to use only one busy tone on international circuits.
- (4) The N.U. tone is of little importance for international traffic on account of the rare occasions when it is used.
- (5) Ringing tone is necessary.

It is recommended that the busy tone and the ringing tone should be regulated as follows :—

Both the busy tone and the ringing tone contain repeated signals made up as follows :—

For the busy tone, a tone and a silence; the duration of the silence should be at least 400 ms.; the duration of the tone and the silence together ought to last for a period between 500 and 1 500 ms.

The ringing tone may comprise a single tone period or a succession of tone periods of the length of one second and followed by a silence of a length equal to or greater than two seconds.

Directive on the Arrangements to be made to Prevent Interference on International Circuits due to Voice Frequency Systems used on National Systems

It is, in fact, difficult to specify the general precautions capable of avoiding interference in national systems which use frequencies other than 600 or 750 p : s when these systems are attached to an international circuit. However, for national systems utilizing 600 and 750 p : s chosen by the C.C.I.F. and connected together by international circuits, the following recommendations can avoid interference to the national systems. It is recommended that means should be provided to prevent a voice frequency current passing from the national to the international circuit if its length exceeds :—

400 ms. for a single frequency (600 or 750 p : s),
or
150 ms. for a compound frequency (600 and 750 p : s).

July 6, 1938.

BIBLIOGRAPHY

1. *Journal I.E.E.*, 1934, Vol. 75, p. 545. "Development in Long-Distance Telephone Switching," T. S. Skillman.
2. *I.P.O.E.E.* Paper No. 162, 1937, "V.F. Signalling on Trunk Circuits," T. H. Flowers—B. M. Hadfield.
3. *Bell Laboratories Record*, November, 1938, Vol. XVII, No. 3. "Time Intervals in Telephone Conversations," O. J. Murphy.
4. British Post Office Research Station Report No. 9947, December, 1938, "Voice Immunity Tests of 2-Frequency Receivers."
5. G. B. Patent 414 423, "Signalling on Lines Fitted with Echo Suppressors."
6. G. B. Patent 489 545, "Splitting V.F. Lines by Use of Prefix Signal."
7. G. B. Patent 489 609, "Tandem Switching on V.F. Lines."
8. G. B. Patent 489 755, "V.F. Signalling on Lines with Intermediate Echo Suppressors."
9. G. B. Patent Application No. 15102/38, "Neutralizing Intermittent V.F. Signal Currents."

Fundamental Transmission Planning of Telephone Networks

Local and Toll Area Planning to meet the C.C.I.F. Recommendations

By BRUCE H. McCURDY

PART I.—THE C.C.I.F. RECOMMENDATIONS LIMITING NATIONAL TRANSMITTING AND RECEIVING LOSS

EDITOR'S NOTE.—*This article is the first of a series on "Fundamental Transmission Planning of Telephone Networks." Part I of the present article considers the various reasons leading up to the latest recommendations of the C.C.I.F. for the General European Toll Switching Plan and outlines the general problem of co-ordinating national and international design standards. In Part II, which will appear in an early issue of this Journal, various practical measures for achieving this co-ordination without imposing restrictions on the national networks will be discussed.*

I. INTRODUCTION

THE introduction before the C.C.I.F. of the question of a fundamental plan for the design of the European network has raised a considerable number of questions as to what a fundamental plan is, what its functions are and how it can be carried out in practice; and, now that the C.C.I.F. has presented a series of recommendations under the title of "Guiding Principles for the Preparation of a Fundamental Plan for Europe," there have followed questions as to what these "Guiding Principles" are and how they can be lined up with the design and engineering of the national systems making up the European network.

In a previous paper¹ it was stated that the operating engineer designing a telephone network was faced with the problem of meeting two major requirements:

- (a) Maximum efficiency in circuit and equipment usage; and
- (b) Maximum economy in plant construction and operating costs.

Putting it another way, one may say that the provision of an economical overall service requires the following ideals to be met as far as is practically possible:

- (1) Minimum circuits for a given volume of traffic and standard of service;
- (2) Minimum grade of circuits throughout the system consistent with the demands of satisfactory overall transmission;

- (3) Minimum construction and operating costs for the facilities provided.

Fundamental plans are the key to the realization—within practical limitations—of these three requirements. They deal directly, however, only with the first two, the third being met by what is usually termed plant extension studies. The fundamental plan engineer, after a study of all relevant factors, arrives at certain basic conclusions as to what facilities are required, classifies them in accordance with their functions, and assigns to each class of facility certain minimum performance requirements. With these as a basis, the various engineering sections proceed with the specific planning of lines, cables and equipment in order to meet the necessary requirements; and, with the plant extension, engineers prepare the specific construction programme to meet as economically as possible the overall requirements embodied in the fundamental plan.

It should, of course, be kept in mind that there is a constant inter-play between the fundamental plan and plant extension studies. The plant in existence and the practical economics of obtaining, as the art changes, a circuit of given characteristics will have a direct bearing on the basic standards or guiding principles, and the latter will change year by year in the light of changing conditions. In other words, the fundamental plan is not, and never can be, static. It is in effect the crystallization of a continuing investigation of overall conditions into a series of basic day-by-day rules.

Furthermore, the number of inter-related variables involved in planning an overall net-

¹ "Toll Plant Engineering," by Bruce H. McCurdy, *Electrical Communication*, January, 1933.

work is so great that, although the aim is *minimum* amount of plant and *minimum* unit costs, the actual result will always be in the nature of the best practicable approach to these ideals. This fact should not, however, be taken as reflecting in any way on the value of fundamental plan studies. A partial approach to the ideals is far better than a hit-or-miss substitute. Moreover, as indicated herein, and as will be elaborated in future articles, one of the main functions of a fundamental plan is to segregate the various problems; to determine limits within which certain factors may be economically varied without appreciably affecting costs; and to disclose the major factors which do affect costs. By concentrating on these major factors within the ranges where they are shown to have a direct effect on overall costs, their control in the direction of achieving maximum overall economy and a satisfactory service to subscribers becomes a practicable engineering problem.

In considering fundamental planning as a whole, the present paper, which deals with a specific case of application, does not logically come first. Since, however, the C.C.I.F. has, as a result of some four years' work, produced certain fundamental "Guiding Principles" which, in the opinion of the C.C.I.F., represent the best compromise between the ultimate "ideal" and present realization; and, since consideration of the methods by which these "Guiding Principles" were arrived at and can be made to correlate with national design requirements will illustrate many of the basic considerations in the science of fundamental planning, it has been thought advisable to start with this specific case and to work back subsequently to some of the more basic considerations.

II. THE STANDARD INTERNATIONAL CONNECTION

It will be noted that the C.C.I.F. "Guiding Principles for the European Toll Plan" starts with the definition of two so-called "standard international connections," and then proceeds to specify certain performance characteristics for the various parts of the overall connection under various conditions of use.

Primarily the C.C.I.F. is interested only in the provision of a satisfactory grade of *inter-*

national service. It might consequently be argued that, having specified the minimum performance which may be allowed for any subscriber connected to an international circuit, its task is complete, so that consideration of the question of the form or general make-up of the national systems is unnecessary. Two important reasons make such procedure unfeasible.

First, no one set of established limits could adequately define general performance applicable to any limiting subscriber in terms which would have any meaning to the national design engineer. Certain subscribers will be connected directly to the international circuit, others will reach the international circuit over built-up connections involving one, two, three or even more intermediate links of different lengths and different electrical characteristics. Each individual connection will not only present different performance characteristics as seen from the international switching point; but, also, because of the different electrical characteristics involved, it will have a direct effect on the performance of the international circuits themselves.

Secondly, one of the functions of the fundamental plan is to provide a meeting point between the engineering and the traffic staffs. In order to meet the two requirements of *minimum circuits* and *minimum grade of circuits* it is necessary that there be a very definite understanding between the traffic and the engineering groups, not only as to what and how many circuits are required, but also as to just what functions these circuits must perform (i.e., are they terminal circuits or will they be switched? If they are for switched traffic, to what will they be switched at their two ends?).

Experience has shown that the most practical solution of the problem is to deal in terms of certain "standard" or typical connections and to set the transmission limits in terms of these "standard" or typical combinations, always keeping in mind that such requirements as are set should be as broad as possible in order to allow each administration or operating company to engineer as economically as possible for its own peculiar set of conditions for both national and international service.

Consequently, one of the first steps taken by the European Switching Plan Committee was to gather information regarding the general form

of the national and international networks throughout Europe; and, after making comparisons, to see whether or not a "standard" type of connection could be adopted to serve for Europe as a whole. After an exhaustive study of existing networks it was found that, despite divergent conditions which had to be catered for in the various national systems, there was a fairly close agreement between the methods and the standards adopted, and that a "standard" circuit could be defined fitting the majority of conditions in a broad way. This standard international connection is illustrated in Fig. 1; and, in Fig. 2, are shown the standard switching connections in certain European countries as compared with the standard C.C.I.F. international connection.

As will be seen from Fig. 1, the "Recommendations" of the C.C.I.F. for the General European Switching Plan provide for two cases: (a) The general case of an international circuit used for switching beyond the international centre to any subscriber in the national network

(except those in the immediate vicinity of the international switching centre); and (b) the case of an international circuit used for providing service to subscribers in the immediate zone, called the "terminal zone," around the international switching centre. This division into two specific cases results from both technical and practical operating considerations, well known to telephone engineers. A brief summary of the underlying reasons may, however, be helpful.

As will be shown later, maximum economy in the design of the national systems imposes the requirement that the loss in the international circuit (when used in a long built-up connection of the form of Fig. 1-A) be kept as low as possible. When the international circuit is extended at its two ends as indicated, a relatively low equivalent is possible. If, however, the international circuit is terminated in a subscriber's loop or in a subscriber's loop plus only a short junction circuit, a number of factors come into play, primarily echo, stability and crosstalk. It is, consequently, impracticable in this latter type of connection to work the international circuit at the low losses to which it can be brought in the "via" or transit case of Fig. 1-A. Technically, there is, of course, no reason why a gain should not be introduced at the terminal of the international circuit such that the overall connection is reduced for each type and length of connection to the minimum value consistent with keeping the various factors mentioned within reasonable limits. The complexity involved by such a procedure is, however, usually not justified by the slight additional gain in transmission which would result, and it has been found more practical to deal with the two fundamental cases: (a) The transit or "via" condition in which the international circuit may be reduced to very close to zero attenuation; and (b) the limiting terminal condition, where the international circuit must be worked at a relatively high attenuation. The exact division between these two conditions depends largely on the type of distribution beyond the international switching centre, although it will usually be found to be as follows:

- (a) All connections to or beyond a centre of the next lower category (i.e., a zone

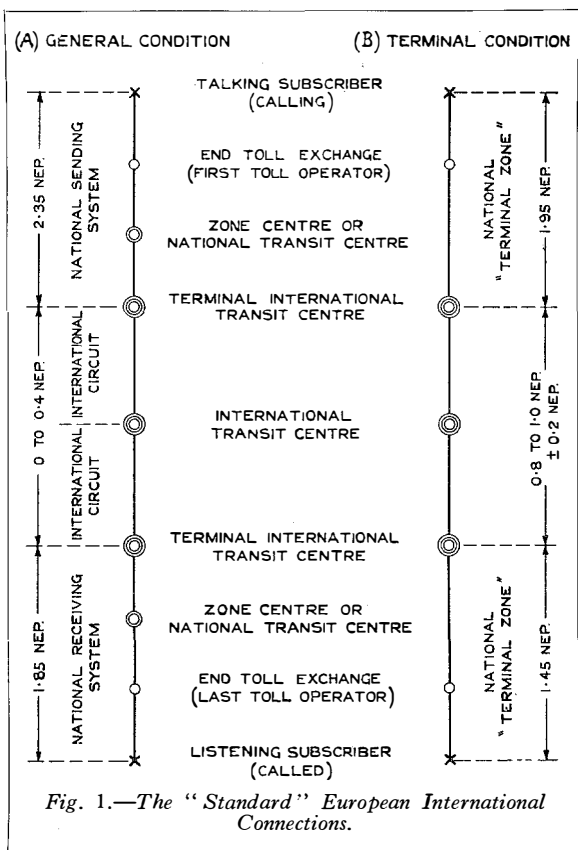

centre) will come under the first classification ;

- (b) All connections reached directly from the international switching centre without passing through a zone centre will come under the second classification. This would include :
- (1) Direct subscriber connections ;
 - (2) Connections to small tributary or satellite offices connected to the international switching office ;
 - (3) Connections reached via a toll exchange tributary to and in the same zone area as the international switching centre.

There is, of course, under the above division, always a question as to whether the case of a long toll circuit between a terminal international transit centre and a so-called "end toll exchange" should not be included under category (a) above, with the consequent introduction of gain in the international circuit at the terminal international transit centre. If such a circuit is of considerable length and made up of a type of facility similar to the circuits connecting the zone centres with the international transit centres, no technical difficulty is involved. However, as will be seen later, unless the toll centre at the far end of such a circuit serves a large area with other tributary toll centres clearing through it, the losses will not be such that the additional gain will be necessary. If, on the other hand, the centre in question does serve a large area with other outlying toll centres feeding through it, it is in reality a "zone centre" and should be classified as such, automatically coming under the above category (a).

III. BASIC PERFORMANCE REQUIREMENTS FOR THE "STANDARD" INTERNATIONAL CONNECTION

Having decided upon the general form of what may be termed the "standard" international connection, the C.C.I.F. began the study of the electrical characteristics of international circuits as well as the characteristics of the national systems as seen from the end of the international circuit. The first point considered was attenuation and since, under the present volume method of expressing performance, it is

the most prominent factor, the present article deals mainly with the problem of the allocation of attenuation limits to the various parts of the connection. In attacking this phase of the problem it was again necessary for the C.C.I.F. to consider not only the future "ideal" allocation of transmission characteristics, but also the characteristics which are imposed to-day by the existence of extensive and well developed national systems the plant of which must continue to be used throughout its economic period of usefulness. Investigation of the electrical characteristics of existing national networks showed rather more variations than the general similarity in form would indicate, especially with respect to the allocation of transmission characteristics to the individual parts of the various networks. On the other hand, the overall performances presented by the national systems, at least so far as the present volume method of expressing performance is concerned, were sufficiently uniform to warrant a tentative specification of a standard limiting value for national transmitting and national receiving losses, with corresponding limits for the performance of the international circuit when in the "via" or in the terminal condition. The values specified by the C.C.I.F. are indicated in Fig. 1. As will be noted, they differ for the two standard cases. In order properly to understand both cases and the reasons behind the limits proposed by the C.C.I.F., it may be well to review briefly how these limits were arrived at.

The basic requirement, from the standpoint of overall reference equivalent toward which the recommendations of the C.C.I.F. aim, is the provision of an international connection which will not exceed 4.6 nepers between limiting subscribers. This value of 4.6 nepers (40 db.) is considered, under the present volume method of expressing performance, the limit for a commercial connection.

The portions of the circuit in Fig. 1 represented by the lines from the International Switching Centre to the subscriber are national circuits ; that is, although used for building up international connections, they are designed primarily for national service. The fact that they are used mainly for national service, and greatly exceed the number of international

circuits, makes it essential that any allocations of losses should be such as to give the greatest possible latitude in national design; otherwise, there will be danger of running up the plant investment for these circuits far above that dictated by their main utilization, i.e., national service. For these reasons the tendency of late years has been to place the emphasis on reducing as far as possible the loss introduced by the international circuit, allowing more and more loss in the national portion of the network.

Since both national and international standards are based on a reasonable limit for a commercial conversation, and since subscribers to-day are demanding practically the same grade of service on an international as on a national call, the desirability of a low equivalent international link is obvious. From the standpoint of attenuation only, the achievement of a zero circuit between international centres for the "via" condition is, within certain limits, practicable. From other standpoints, however, mainly echo, stability and crosstalk, coupled with certain variations in the equivalent of circuits with time (capable of control only within certain limits), the international circuit cannot be considered, for general planning purposes, as working satisfactorily on an absolute zero equivalent. This consideration will be discussed in a later section of this article. At present, it is sufficient to say that, after a very exhaustive study of present-day circuits and the conditions met with in the national portion of the network, it has been decided to set a nominal value for the attenuation of the international link at zero with a possible tolerance, due to the practical difficulty of adjusting a circuit to an exact limit, of plus 0.1 neper for each link. This tolerance of 0.1 neper is considered as positive since, because of possible singing in the open circuit condition, it is desirable that a circuit never be lined up to a

negative attenuation, no matter how slight. Although the "typical" overall connection shows but two international links, three links are still met with and must be permitted for some time to come as representing the limiting condition which must be met if universal interconnection is to be arrived at. In the case of the limiting international connection, therefore, we may have three circuits in tandem, each with a nominal transit equivalent of zero and each with a possible tolerance of plus 0.1 from this nominal value. In addition to the difference between the exact nominal value and the value which can, in practice, be arrived at (i.e., the 0.1 tolerance) there are the unavoidable changes in the equivalent of the individual circuits with time, due to battery variations, ageing of valves, temperature variations, etc. After considerable study of actual conditions found in practice, the C.C.I.F. has concluded that, in an international connection made up of three international circuit attenuation which can be counted on for planning purposes is 0.4 neper. If, therefore, we are to aim toward never exceeding 4.6 nepers for any overall connection, there remains, for the sum of the national transmitting and national receiving loss at each end, a value of 4.6 - 0.4 or 4.2 nepers (36.5 db.).

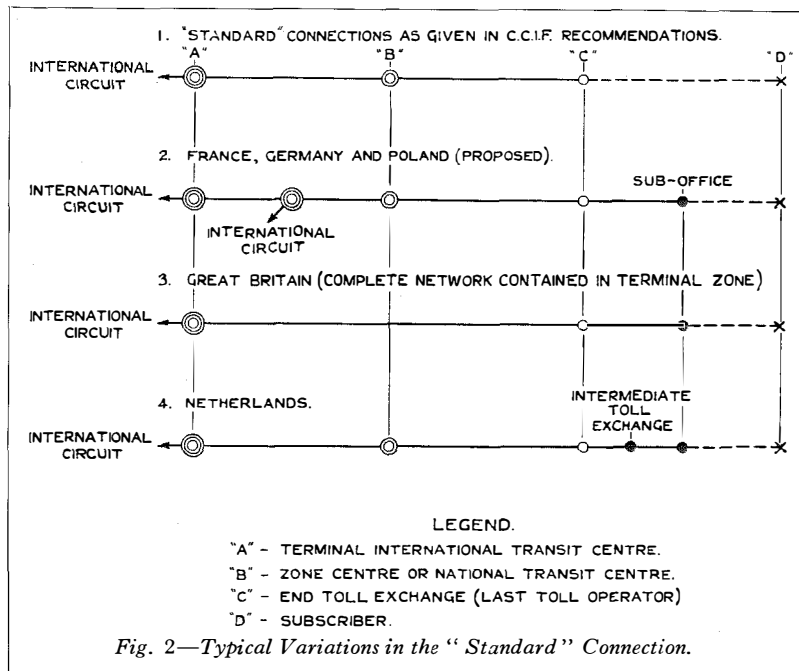

Fig. 2—Typical Variations in the "Standard" Connection.

The division of this 4.2 nepers into limits for the national transmitting and the national receiving losses again required an examination into the condition imposed by the existing plant; in this case, the average characteristics of the subsets used throughout Europe. An examination of the major types of subsets in use in Europe showed that, for the average limiting condition, the transmitting reference equivalent was 0.5 neper (4.3 db.) greater than the receiving reference equivalent.

Breakdown of the 4.2 nepers into limits for the national transmitting and national receiving limit was accordingly as follows:—

$$\begin{aligned} T + R &= 4.2 \text{ nepers ;} \\ R &= T - 0.5 \text{ neper ;} \\ \therefore T &= 2.35 \text{ nepers (20.5 db.), and} \\ R &= 1.85 \text{ nepers (16 db.),} \end{aligned}$$

where T is the national transmitting loss and R the national receiving loss.

The design engineer may find that for particular conditions his own allocation may vary somewhat from these figures; that is, if one value is met, the other will be exceeded or will not be arrived at. He must, however, design to meet whichever is the limiting case for his particular network, and must assume that the corresponding limit will exist at the far end.

Let us now consider the second "standard" condition: the so-called "terminal" connections. Although low equivalent circuits in the transit condition where the international circuit is terminated in long high-grade extensions can be used without undue difficulty from the standpoint of echo, crosstalk and stability, these latter factors introduce difficulty in the shorter connections radiating from the international centre unless special equipment such as stabilized repeaters are employed, and excessively severe limits for the crosstalk requirements of cables are imposed.

The case of the terminal subscriber connected directly to the end of the international circuit (the junction between the local board or automatic office to the toll board being of negligible length) has been rather exhaustively discussed in the C.C.I.F. and in numerous technical publications. It should be mentioned that experience has shown that, because of echo,

stability and crosstalk, it is necessary to work the international circuit at a considerably higher value than the 0.1 to 0.4 neper arrived at above. An examination of circuit lengths, possible variations, etc., made of international circuits throughout Europe led to the conclusion that in order to care for these terminal conditions, the minimum safe value of the nominal equivalent of international circuits when connected to subscribers in the immediate local area surrounding the international exchange is 0.8 neper (7.0 db.) for a 4-wire circuit and 1.0 neper (8.7 db.) for a 2-wire circuit. A study of the possible variations of such circuits from the nominal (actual variations of adjustment and possible variations with time) has indicated that for planning purposes it should be assumed that such circuits will vary plus or minus 0.2 neper (1.7 db.) from the nominal. The limiting case for planning, therefore, must be 0.2 neper (1.7 db.) greater than the above nominal values, or 1.0 neper (8.7 db.) for 4-wire circuits and 1.2 neper (10.4 db.) for 2-wire circuits.

Since, in the majority of cases, there will be both 2-wire and 4-wire circuits terminating at the international switching centre, the local terminal area must be designed in accord with the maximum loss which may be experienced in the international circuit, i.e., 1.2 neper. This leaves 3.4 nepers for the sum of the national transmitting and national receiving losses at the two ends. Taking account of the 0.5 neper difference between the transmitting and the receiving reference equivalent of the average subset, we arrive (following the same reasoning as for the "via" case) at 1.95 nepers (17 db.) for the maximum allowable transmitting loss for the terminal exchange area and 1.45 nepers (12.5 db.) for the maximum allowable receiving loss for the same area.

IV. APPLICATION OF THE C.C.I.F. RECOMMENDATIONS TO THE NATIONAL NETWORKS

From the standpoint of national transmitting and national receiving loss limits, the C.C.I.F. goes no further than setting the above limits, leaving it to the discretion of the various administrations and operating companies to allocate the loss between the various parts of

the national systems so that the above limits are not exceeded. The stipulation of these very specific limits does, however, require a close investigation on the part of national design engineers to insure (1) that the national system will meet the requirements of the international connection and (2) that, in meeting them, limits are not set for the national plant which are out of line with its major field of use, i.e., national service.

The problem may be stated roughly as follows: If we take the two standard or typical national conditions outlined in the C.C.I.F. recommendations and shown diagrammatically in Fig. 3-A and B, we find that from the international standpoint the following conditions must be met:

Case (a) The General "via" Connection

In the first place, a gain must be introduced at the end of the international circuit equal to half the difference between the nominal terminal equivalent and the nominal "via" equivalent of the international circuit.

In the second place, the various connections which may be set up in the national network must meet the following conditions, as seen from the conventional origin² of the international circuit:

Transmitting:

$$\begin{aligned} X + a + b + (c)_t &= 2.35 \text{ nep. (20.5 db.)} \\ X + a + (d)_t &= 2.35 \text{ ,,} \\ X + e + (f)_t &= 2.35 \text{ ,,} \\ X + (g) &= 2.35 \text{ ,,} \end{aligned}$$

Receiving:

$$\begin{aligned} X + a + b + (c)_r &= 1.85 \text{ nep. (16 db.)} \\ X + a + (d)_r &= 1.85 \text{ ,,} \\ X + e + (f)_r &= 1.85 \text{ ,,} \\ X + (g)_r &= 1.85 \text{ ,,} \end{aligned}$$

Letters not in parenthesis represent circuit equivalents. Letters in parenthesis represent the reference equivalent of the limiting combination of subscribers' set and loop met with in the central office area in question, the subscripts *t* and *r* denoting transmitting and receiving, respectively. The conception of *total reference equivalent as seen from the central*

office should perhaps be emphasized. There are several methods in force for arriving at this value. Some administrations work in terms of the nominal reference equivalent of the subset on the standard 300 ohm loop, as specified by the C.C.I.F. for comparison work, and correct this to take account of loop attenuation, change in battery supply loss when the loop differs from 300 ohms, and reflection losses. Others work from curves which give directly the reference equivalent of the total combination of subscribers' set plus loop as measured from the central office. As will be shown in later articles, this latter method greatly facilitates the study of economic distribution of losses in the local network. For the moment, however, the important point to note is that, regardless of the manner of arriving at the result, the figure to be used, if it is to have any meaning in connection with the limiting national transmitting and receiving loss, is not the nominal reference equivalent of the subset but the actual reference equivalent of the *subset plus the limiting loop condition* as seen from the central office.

Case (b) The X "Terminal" Condition

The international circuit in this case remains at its nominal "terminal" equivalent; that is, no gain is introduced in the international circuit at the terminating international switching centre in question. The various parts of the "terminal zone" network (Fig. 3-B), which may be connected to the international circuit under this condition, must meet the following requirements:

Transmitting:

$$\begin{aligned} a + b + (c)_t &= 1.95 \text{ nep. (17 db.)} \\ a + (d)_t &= 1.95 \text{ ,,} \\ e + (f)_t &= 1.95 \text{ ,,} \\ (g)_t &= 1.95 \text{ ,,} \end{aligned}$$

Receiving:

$$\begin{aligned} a + b + (c)_r &= 1.45 \text{ nep. (12.5 db.)} \\ a + (d)_r &= 1.45 \text{ ,,} \\ e + (f)_r &= 1.45 \text{ ,,} \\ (g)_r &= 1.45 \text{ ,,} \end{aligned}$$

Superimposed on these requirements, and far more important to the national design engineer since they represent the major use of the circuits, are the transmission limits necessary

² See C.C.I.F. Proceedings, Tome 1 ter, page 37.

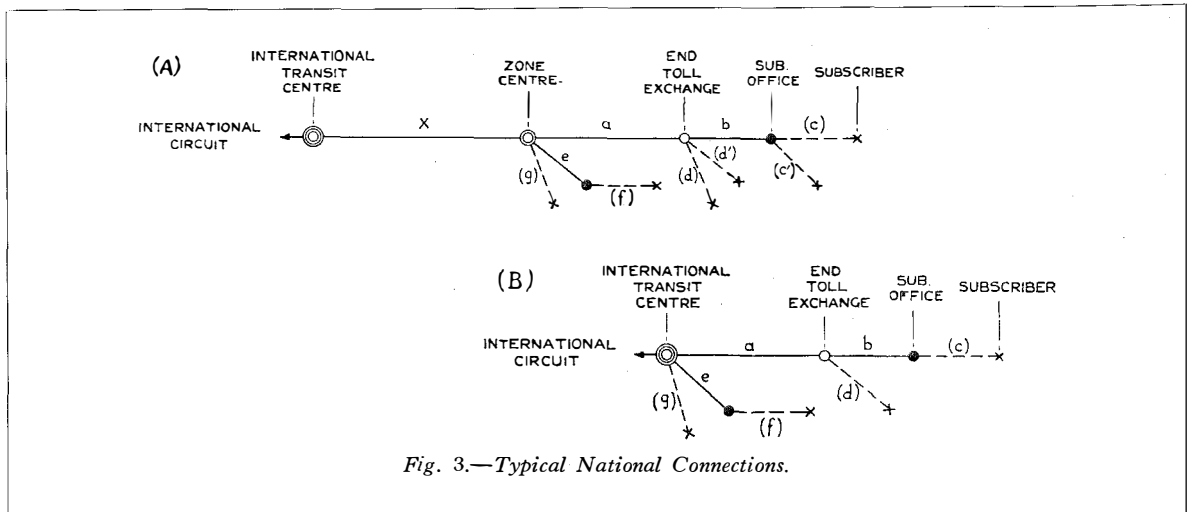

Fig. 3.—Typical National Connections.

to meet the various national standards. There will be, for instance, a certain established standard for the limiting connection in a local area such as that, say, served by an end toll exchange. Loops and junctions in this area must be designed so that such combinations as $(d)_t + (d')_r$, $(c)_t + (c')_r$, and $(c)_t + b + (d)_r$, all meet this standard. This requires the answer to such questions as what limits should be set for loops of the type (d) and (c) ; what is the most economical distribution between the losses in a limiting loop (c) and the junction b ; and, finally, how can these limits be co-ordinated with the international requirements already outlined. It is the principal function of the fundamental plan engineer to obtain a practical

answer to such questions, the answers being expressed in terms of specific design standards for each part of the network. With such specific design standards as a basis, the plant extension engineers may then go ahead with the laying out of the plant, and the setting up of construction programmes so as to meet, as economically as possible from the construction standpoint, the requirements necessary for furnishing a satisfactory service.

In Part II of this article certain practical steps involved in co-ordinating the various national and international design standards, as well as the breakdown of the rather complex overall design problem into a series of simple stage-by-stage investigations, will be discussed.

Calculation of Triode Constants*

By J. H. FREMLIN, M.A., Ph.D., A.Inst.P.

SUMMARY.—A new treatment of the equivalent diode is proposed, from which formulæ for anode current and mutual conductance in plane or cylindrical triodes are obtained in terms of the penetration factor, the inter-electrode distances, and the voltages applied to grid and anode. In the plane case the values found differ from those given by the most widely used expressions by a factor

$$\left[\frac{1 + D}{1 + D \left(\frac{l_a}{l_g} \right)^{4/3}} \right]^{3/2},$$

which may in some circumstances be considerably less than 1.

In the cylindrical case a similar but more complex factor is obtained. The expressions obtained for the plane case are shown experimentally to be more nearly correct than previous expressions.

These formulæ can only be used in cases for which the penetration factor can be calculated. Beginning with Maxwell's expression for the potential distribution due to a charged grid of fine wires it is shown how this distribution can be calculated for the case of a grid close to the cathode (Appendix D), and hence the value of penetration factor can be calculated for zero current at these close spacings.

It is shown experimentally that the value of penetration factor thus obtained may be used with some accuracy up to considerable current densities. Calculated and experimental values of mutual conductance at close spacings are compared, and it is shown that if allowance is made for emission velocity very close agreement can be obtained down to values of grid-cathode clearance of only a few per cent. of the grid pitch. A definite maximum value of mutual conductance for constant current density is shown to occur at a cathode-grid clearance of the order of half the grid pitch.

INTRODUCTION

IT is of fundamental importance in the design and in the development of thermionic valves to be able to determine in advance what the characteristics of such valves will be. In the case of a diode it is already possible to do this to a very considerable accuracy when the electrodes are either parallel planes or concentric cylinders. Where there are one or more grids between the anode and the cathode, however, the position is less satisfactory. Schottky, Miller¹, King², and others have derived expressions for the amplification factor μ of an infinite plane triode and of a cylindrical triode of infinite length in which the ratio $\frac{\text{wire diameter}}{\text{grid pitch}}$, d/a , is assumed small (less than 0.1). Vogdes and Elder³ have obtained a formula available for larger values of d/a up to about one-third, and Ollendorff⁴ gives a method of calculation said to be valid for all values of d/a . The theoretical values of

μ agree very well with experiment so long as the distance of the grid from the cathode l_g is greater than about one grid pitch.

Calculations of anode current per unit area i and mutual conductance per unit area g_m are not usually as successful, though a large number of formulæ have been proposed both on theoretical and on empirical grounds. The work described in this paper was undertaken in the attempt to make more accurate calculations possible for triodes. It was especially concerned with the case in which the grid is very close to the cathode, for which relatively little experimental work has been published. Before an expression could be developed for this case it was necessary to investigate the expressions for current in the simpler conditions where the wires of the grid are thin and where the cathode-grid distance is appreciably more than one grid pitch.

In Part I theoretical formulæ are developed for i and g_m when the cathode-grid distance is greater than the grid pitch, and the apparatus used for testing these is described.

In Part II it is shown how these formulæ may be used when the grid is very close to the

* Republished from the *Philosophical Magazine and Journal of Science*, Vol. 27, No. 185, June 1939.

¹ For numbered references see Appendix B.

cathode so long as the reduction of penetration factor is taken into account.†

Definitions of the symbols used and a table of references are given at the end in Appendices A and B.

PART I

THEORY

The expressions most frequently used⁵ for anode current and mutual conductance are (omitting a small contact-potential term):

$$i = \frac{2.34 \times 10^{-6} (V_g + DV_a)^{3/2}}{l_g^2 (1 + D)^{3/2}} \dots\dots(1)$$

amps. per unit area,

where $V_a V_g$ are the anode and grid potentials, D is the penetration factor (reciprocal of the amplification factor), and l_g is the distance of the plane of the grid from that of the cathode, and

$$g_m = \frac{\partial i}{\partial V_g} = \frac{3.51 \times 10^{-6} \sqrt{V_g + DV_a}}{l_g^2 (1 + D)^{3/2}} \dots(2)$$

amps. per volt per unit area

for the plane case, and

$$i_t = \frac{1.47 \times 10^{-5} (V_g + DV_a)^{3/2}}{r_g \beta_{cg}^2 (1 + D)^{3/2}} \dots\dots(3)$$

amps. per unit length,

$$g_m = \frac{2.20 \times 10^{-5} \sqrt{V_g + DV_a}}{r_g \beta_{cg}^2 (1 + D)^{3/2}} \dots\dots\dots(4)$$

amps. per volt per unit length

for the cylindrical case⁵. Here r_g is the radius of the grid cylinder and β_{cg}^2 is a function of r_g/r_c (where r_c is the cathode radius) given by Langmuir⁷.

These formulæ were not calculated directly for a triode, but indirectly as follows. Child⁶ and Langmuir⁷ showed how the space-charge limited current could be calculated through any diode, the electrodes of which were infinite parallel planes or infinite concentric cylinders. Then, if it could be proved that the current through a given triode was exactly that which

would pass through a particular diode whose dimensions and anode potential were known, this current would be known. The particular diode is called the "equivalent diode." Its electrode parameters naturally depend upon those of the triode to which it is equivalent, and if the conception is to be of value they must be calculable in terms of these.

The formulæ (1) and (2) above were calculated on the simple assumption, without detailed analysis, that the diode with cathode-anode distance l_D given by

$$l_D = l_g \dots\dots\dots(5a)$$

and with anode voltage V_D given by

$$V_D = V_g + DV_a \dots\dots\dots(5b)$$

was nearly equivalent to the triode. The derivation of the correction factor $\frac{1}{(1 + D)^{3/2}}$

is given by (among others) Chaffee⁸; the reasoning seems at times to be somewhat obscure. Formulæ (3) and (4) were found similarly, assuming $r_D = r_g$. Other authors have made different but still arbitrary assumptions. For example, Miller¹ assumed that a diode giving the same cathode field as the triode in the absence of space-charge, and having its anode in the same position as the anode of the triode, would give the same current. His formula is as follows:

$$i = \frac{2.34 \times 10^{-6} (V_g + DV_a)^{3/2}}{\sqrt{l_a} (l_g + Dl_a)^{3/2}}$$

amperes per unit area.

Owing to the assumption that

$$l_D = l_a$$

this underestimates the current considerably and is not much used.

Benham¹³ has recently put forward reasons why a formula similar to Miller's, but putting l_D instead of l_a , where

$$l_D = l_g + Dl_a,$$

should be accepted. Unlike Miller's formula this ensures that the denominator tends correctly to l_g^2 as D becomes very small.

For large values of D (0.1 or above, say, for ordinary valve dimensions) these formulæ particularly Benham's, give more nearly the current which is determined experimentally than does formula (1) given above. It does not, however, seem to have been realized that

† Throughout this paper the quantity "penetration factor," sometimes described as "Durchgriff," is in general used in preference to its reciprocal, the amplification factor. The use of the term "amplification factor" seems rather inapt in many cases, particularly in the consideration of electrostatic problems, and is therefore confined to cases in which its physical meaning is clear.

it is possible to calculate the current through a triode without direct reference to a particular equivalent diode. This can be done as follows. Consider first the plane case.

If a current of density i is flowing between plane electrodes under space-charge limited conditions, the potential distribution will be given by

$$V^{3/2} = kil^2, \dots\dots\dots(6)$$

where $k = \frac{1}{2.34 \times 10^{-6}}$ if i is measured in amps. per sq. cm and V is measured in volts. Here the cathode is taken as origin of V and of l , and the effects of initial velocity of the electrons are neglected. Equation (6) then merely expresses the Child-Langmuir law. The distribution is shown in Fig. 1. Suppose that the anode and grid of the triode are introduced into the electron stream at such potentials that the original distribution is unaltered, i.e., so that

$$\left. \begin{aligned} V_a &= k^{2/3} i^{2/3} l_a^{4/3}, \\ V_g &= k^{2/3} i^{2/3} l_g^{4/3}. \end{aligned} \right\} \dots\dots\dots(7)$$

We have now a triode with electrode potentials which are known in terms of the total space current which is passing. It is known that the field at the cathode of a plane triode is given by

$$\frac{\partial V}{\partial l} = \frac{V_g + DV_a}{l_g + Dl_a} \dots\dots\dots(8)$$

in the absence of space-charge⁹. When a space-

charge-limited current flows, the cathode field is reduced to zero, and it is known that for any electrode system the current required to do this is proportional to the three-halves power of the cathode field. Hence we know that

$$i = K(V_g + DV_a)^{3/2}, \dots\dots\dots(9)$$

where K depends on the dimensions of the valve.

Substituting from (7) for V_g, V_a , we have

$$i = K(k^{2/3} i^{2/3} l_g^{4/3} + Dk^{2/3} i^{2/3} l_a^{4/3})^{3/2};$$

$$\therefore K = \frac{1}{k(l_g^{4/3} + Dl_a^{4/3})^{3/2}};$$

$$\therefore K = \frac{2.34 \times 10^{-6}}{[l_g^{4/3} + Dl_a^{4/3}]^{3/2}} \text{ in practical units. } \dots(10)$$

Hence

$$i = \frac{2.34 \times 10^{-6}(V_g + DV_a)^{3/2}}{[l_g^{4/3} + Dl_a^{4/3}]^{3/2}} \dots\dots(11)$$

amps. per unit area,

whence we have

$$g_m = \frac{3.50 \times 10^{-6} \sqrt{V_g + DV_a}}{[l_g^{4/3} + Dl_a^{4/3}]^{3/2}} \dots\dots(12a)$$

amps. per volt per unit area.

From (11) and (12a) we have also

$$g_m = \frac{2.64 \times 10^{-4} i^{1/3}}{[l_g^{4/3} + Dl_a^{4/3}]} \dots\dots\dots(12b)$$

amps. per volt per unit area.

These differ from the usual formulæ used only in the replacement of the term $[1 + D]^{3/2}$ by the term

$$\left[1 + D \left(\frac{l_a}{l_g} \right)^{4/3} \right]^{3/2}.$$

It will be noticed that the equation for current has been derived without explicit reference to the equivalent diode. The form of the equations shows that the triode is equivalent to a particular diode, however, whose dimensions and anode potential (from equations (8) and (11)) are given by

$$l_D = \frac{[l_g^{4/3} + Dl_a^{4/3}]^3}{[l_g + Dl_a]^3};$$

$$V_D = \frac{[l_g^{4/3} + Dl_a^{4/3}]^3}{[l_g + Dl_a]^4} [V_g + DV_a]. \dots\dots(13)$$

The difference between this value of l_D and the

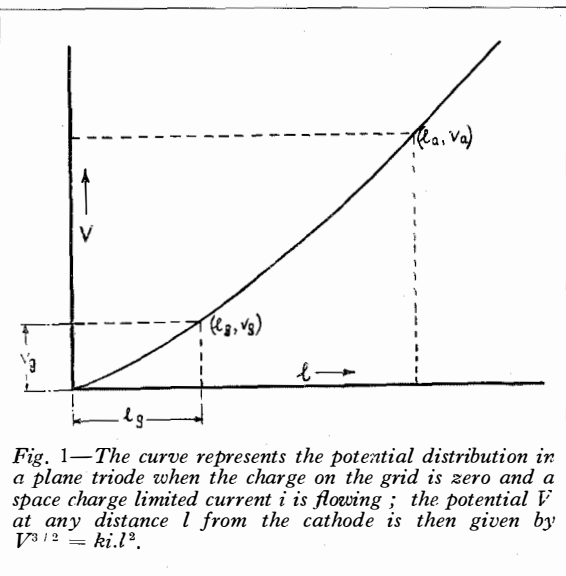

Fig. 1—The curve represents the potential distribution in a plane triode when the charge on the grid is zero and a space charge limited current i is flowing; the potential V at any distance l from the cathode is then given by $V^{3/2} = kil^2$.

values hitherto assumed expresses the difference between equation (11) and previous formulæ which have been given for current. Diodes giving the same cathode fields in the absence of current, but having different electrode spacings, pass different currents, and the importance of this fact has not been sufficiently realized.

No mention has been made so far either of the fact that part of the current will be stopped by the grid wires when these are positive or of the possible variation of the penetration factor. The effect of the former will always be very small, as if the wires are relatively thin the current will be little affected, while if they are thick the space-charge between grid and anode will anyway be largely shielded from the cathode.

If the penetration factor varies very rapidly the formulæ (12a) and (12b) may be in error, owing to the existence of appreciable terms involving

$$\frac{\partial D}{\partial V_g} \quad \text{and} \quad \frac{\partial D}{\partial V_a}$$

The non-uniformity of space-charge owing to focusing by the grid wires when the grid is negative will not affect the field of the space-charge at the cathode so long as the grid is far enough away for its own field to be uniform.

A similar analysis has been carried out to determine the radius and potential of the anode of the equivalent diode for the case of a cylindrical triode. Given that D can be calculated, the results apply equally well to the squirrel-cage or helical grid in the absence of "inselbildung."* Large grid supports, however, cause a definite "beam" effect which makes many circular section valves obey the formulæ for planes much more closely than they do those for cylinders. With these provisos then we have

$$i_i = \frac{14.7 + 10^{-6}(V_g + DV_a)^{3/2}}{D[(r_a\beta_{ca}^2)^{2/3} + (r_g\beta_{cg}^2)^{2/3}]^{3/2}} \dots(14a)$$

amps. per unit length,

$$g_m = \frac{22.0 \times 10^{-6}\sqrt{V_g + DV_a}}{[(r_g\beta_{cg}^2)^{2/3} + D(r_a\beta_{ca}^2)^{2/3}]^{3/2}} \dots(14b)$$

amps. per volt per unit length.

* The term "inselbildung" is here taken to mean the state of affairs in which emission from the cathode surface is appreciably non-uniform.

The effect of initial velocities has been neglected throughout this discussion. In the case of the plane diode Langmuir¹⁰ has calculated rigorously the potential distribution during flow of current assuming a Maxwellian distribution of emission velocity among the electrons. It would in principle be possible to calculate the equivalent diode on this basis in a manner similar to the above. It is not possible in practice, however, to obtain separate expressions for l_D and V_D , the spacing and voltage of the equivalent diode, though it can be seen that l_D would in general vary with current.

It is possible to obtain a first approximation to the true values by measuring the distances and voltages from the potential minimum rather than from the cathode itself when the distance l_m of this from the cathode can be calculated. It is not difficult to find l_m if the cathode temperature is known, for currents a small fraction of the saturation current, using the formulæ developed by Langmuir. For large currents, approaching the saturation value, initial velocity effects may be neglected. In Appendix C is estimated the correction required to allow for emission velocities to this degree of approximation.

EXPERIMENT

An apparatus has been built by means of which the grid and anode of a plane triode may be moved about at will while the current is flowing. It was desired that the position of the electrodes with respect to one another should be very accurately adjustable over a range of 2 to 3 centimetres. To do this a short but accurate optical bench was built of steel. This was fixed rigidly to a circular steel base, and covered by a bell-jar which was sealed to the base with Apiezon Q. A pumping tube, a tube leading to an ionization manometer, and a tube carrying the necessary insulated electrical leads were soldered into the base, and the whole system could be evacuated by means of an oil-diffusion pump backed by a Cenco Hivac. In Figs. 2 and 3 are shown diagrams of the carriages and frames which were used to support anode and grid. In each case to the small steel carriage A sliding upon the optical bench was bolted a sheet of steatite to which

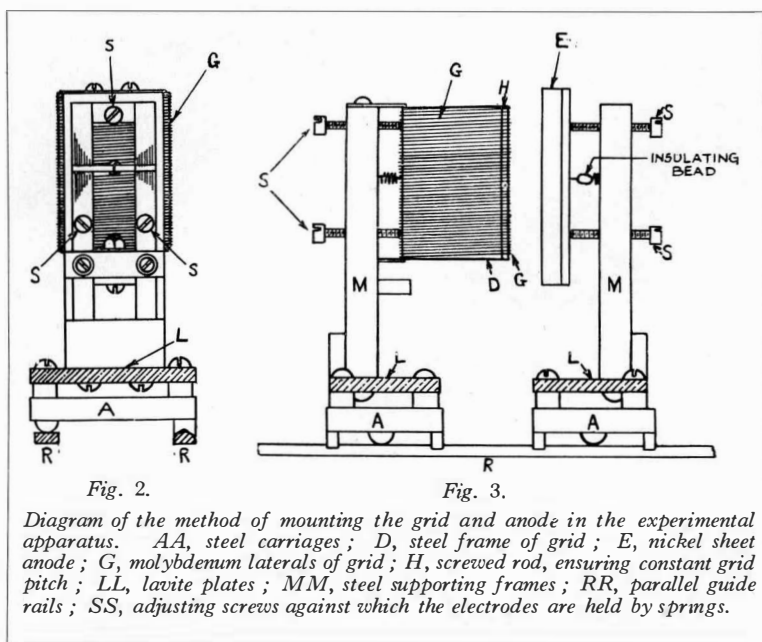

Fig. 2. Diagram of the method of mounting the grid and anode in the experimental apparatus. AA, steel carriages; D, steel frame of grid; E, nickel sheet anode; G, molybdenum laterals of grid; H, screwed rod, ensuring constant grid pitch; LL, lavite plates; MM, steel supporting frames; RR, parallel guide rails; SS, adjusting screws against which the electrodes are held by springs.

the frame M was fixed. The plane of each electrode was adjustable by means of the three screws S, against which the electrode itself was held by a molybdenum spring. The two carriages were moved by means of screwed rods (not shown) operated by steel ground joints lubricated with Apiezon L grease, and the positions of the electrodes were determined by graduations on the moving parts of the ground joints. As the screw used was of exactly 1 mm pitch, one complete rotation represented 1 mm movement of the carriage. It was possible to set the position of either electrode repeatedly to an accuracy of 0.01 mm. In Fig. 3 the cathode support is omitted for the sake of clarity; this was bolted rigidly to the steel base, perpendicular to the steel rails on which the carriages ran. An indirectly heated coated cathode C was used, mounted on steatite insulators attached to a steel supporting frame shown in section at B in Fig. 4. The cathode itself was of unconventional type, as it was necessary to ensure absolute flatness. The working part consisted of a solid piece of nickel, 30 mm by 8 mm by 5 mm thick, ground accurately flat on one face. The heater was contained in a shallow channel milled in the back, and was held in by two or three layers of thin nickel sheet, very lightly attached, to reduce radiation losses. As is indicated by the

section of the whole electrode system shown in Fig. 4, one face only of the cathode C was coated and used.

The cathode C and the frame B (from which it was insulated) were completely surrounded by the light steel frame D carrying the grid wires G. In order that the grid wires should be truly coplanar they were wound upon this frame, of which the edges were very carefully ground flat and parallel. To ensure even pitch two light screwed rods H were welded near the edges of D, and the wires of the grid were wound into the threads at suitable intervals. This avoided the small irregularities always produced by welding. The grid could be

produced by

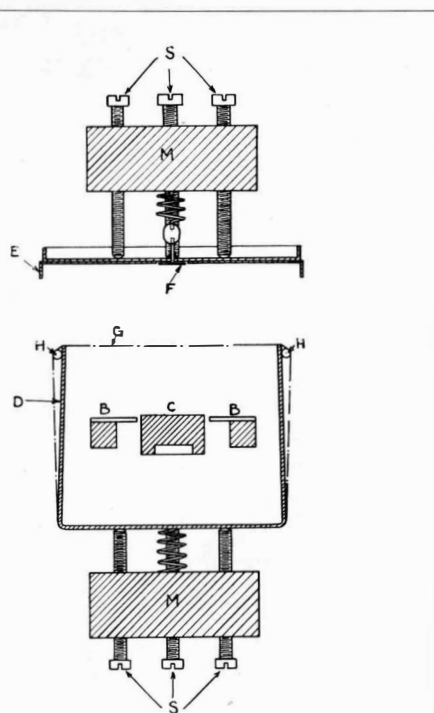

Fig. 4—Diagram to show the electrode construction. BB, shield round cathode; C, indirectly heated nickel cathode; D, steel frame of grid; E, outer "guard" part of the anode; F, centre section of the anode, area 0.575 sq. cm insulated from E by heater coating; G, molybdenum grid laterals; HH, screwed rods fixing the grid pitch; MM, supporting frames; SS, adjusting screws.

adjusted parallel to the cathode extremely well, so that measurements could be made down to a clearing distance of 0.002 cm between the cathode coating and the inner side of the grid wires, although the working length of the grid was 3 cm.

In order to investigate the variation of current and mutual conductance in a planar triode without disturbing edge effects the anode was made of nickel sheet in guard ring form. A small rectangular section F (Fig. 4) was insulated from the main body of the anode E by a thin coating of insulating paste, the whole being baked at red heat *in vacuo* before use. This guard ring structure, though absolutely necessary, was not quite so flat as were the cathode and grid. The position of the centre section F, 1.550 cm long by 0.371 cm broad, was known to 0.004 cm, and the anode at no place departed from flatness by more than this amount.

An ionization gauge was used to measure the pressure. Between it and the apparatus was a small trap which could be surrounded by liquid air. This made it easy to distinguish between air and condensable vapour, and made the finding of leaks a practically painless process. During the experimental work the pressure was maintained at between 5×10^{-7} and 3×10^{-6} mm; the apparatus could be degassed enough for this by running for about a day after the initial activation of the cathode.

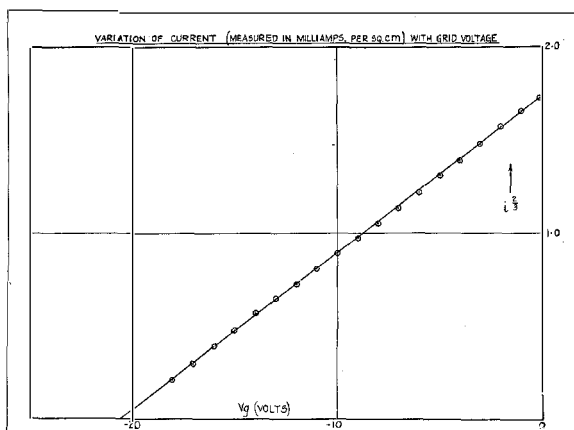

Fig. 5—This shows the variation of anode current density i with grid potential V_g , indicating that the three-halves power law is closely obeyed. Anode potential was 200 volts and the dimensions were as follows: $l_g = 0.170$ cm; $l_a = 0.773$ cm; $a = 0.175$ cm; $d = 0.0089$ cm.

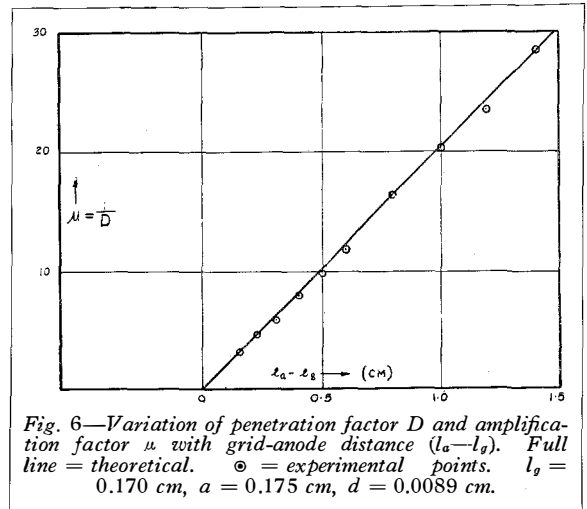

Fig. 6—Variation of penetration factor D and amplification factor μ with grid-anode distance ($l_a - l_g$). Full line = theoretical. \circ = experimental points. $l_g = 0.170$ cm, $a = 0.175$ cm, $d = 0.0089$ cm.

Tests were made to see whether the anode structure was properly carrying out its function of eliminating edge effects. If the edge effects were eliminated, changes in them must also have been eliminated. They could readily be changed by altering the potential V_B with respect to the cathode of the frame B round the cathode (Fig. 4) (B was usually maintained at cathode potential). A grid potential of zero and an anode potential of 200 volts were maintained, the grid being in position midway between anode and cathode. A change from -15 to $+15$ volts of V_B produced no detectable change in the current to the centre section of the anode, I_F , though the current to the outer part of the anode, I_E , was doubled. Change of V_B from -30 volts to $+30$ volts gave a change of I_F from 1.00 to 1.04 mA, while I_E changed from 5 mA to 15 mA.

It seems clear from this that the guard ring was effective. The value of I_F was very sensitive, however, owing to secondary emission, to any small potential difference between E and F (Fig. 4). A change of 1 volt sometimes made a difference of more than 10 per cent. in I_F . Care was taken therefore during all experimental work to ensure that no potential difference was set up; it was hoped that contact potential differences would be small, as E and F were made from the same sample of nickel and were treated similarly throughout.

Figs. 5–9 show some results of the experiments. First, tests were made of amplification factor to see whether the Miller-Schottky

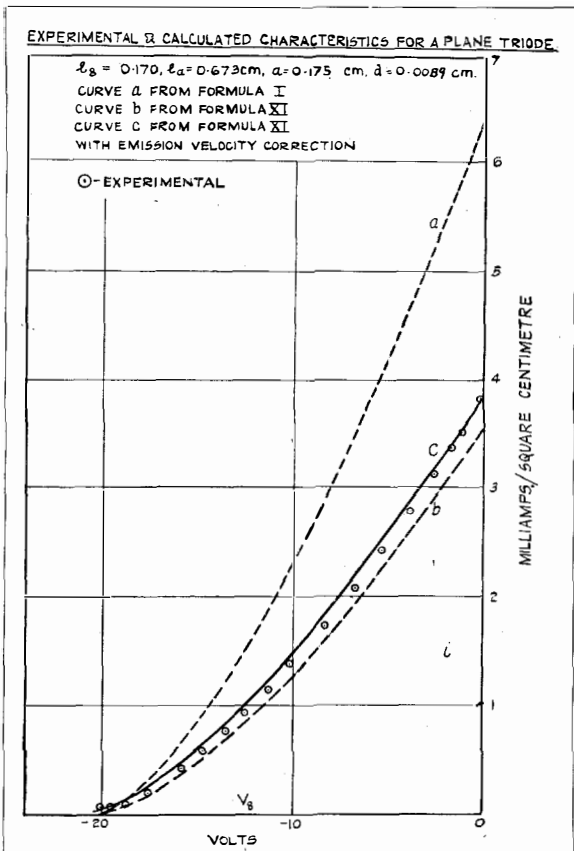

Fig. 7—Experimental and calculated characteristics for a plane triode: Variation of anode current density i with grid potential V_g , at an anode potential of 200 volts. Curve (a) is calculated from formula (1). Curve (b) is calculated from formula (11). Curve (c) is calculated from formula (11) with a correction for initial velocities. Experimental points are given by \odot . $l_g = 0.170$ cm, $l_a = 0.673$ cm, $a = 0.175$ cm, $d = 0.0089$ cm.

calculated and observed amplification factor was obtained. This being so, the relations obtained for current and mutual conductance could fairly be tested.

In Fig. 7 are shown actual measured values of anode current together with curves calculated from equation (1) (curve a) and equation (11) (curve b). It can be seen that curve (b) is considerably more accurate than (a), but that nevertheless equation (11) appreciably underestimates the current. This is very largely accounted for if we take into account the effects of the emission velocity. Curve (c) is calculated from equation (11) as before, but replacing l_g and l_a by $l_g - l_m$ and $l_a - l$ respectively, as is shown in Appendix C, i.e., the position of the potential minimum is calculated and all distances measured therefrom instead of from the cathode surface.

The introduction of a filament for the accurate measurement of contact potential would

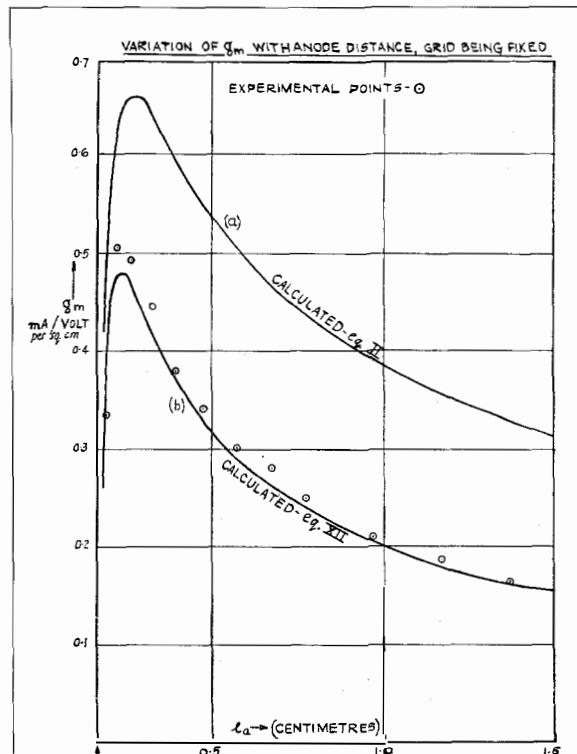

Fig. 8—Variation of mutual conductance per unit area g_m with cathode-anode distance l_a at $V_a = 200$ volts, $V_g = 0$. $l_g = 0.170$ cm, $a = 0.175$ cm, $d = 0.0089$ cm. Curve (a) is calculated from equation (2). Curve (b) is calculated from equation (12a). Experimental points are given by \odot .

formula* could be trusted for the values of d/a , with which it was desired to work. Owing to the double anode construction it was difficult to measure the amplification factor dynamically, and the most accurate method was found to be extrapolation of a line obtained by plotting $I_p^{2/3}$ against V_g to zero current. This method also gave confirmation of the fact that current obeyed the three-halves-power law (see Fig. 5).

Fig. 6 shows that good agreement between

* See ref. 1. For plane electrodes this is

$$\mu = \frac{2\pi(l_a - l_g)}{1} \log_e \frac{1}{2 \sin \frac{\pi d}{2a}}$$

$(l_a - l_g)$ is the distance between grid and anode planes, a is the grid pitch, and d is the grid wire diameter.

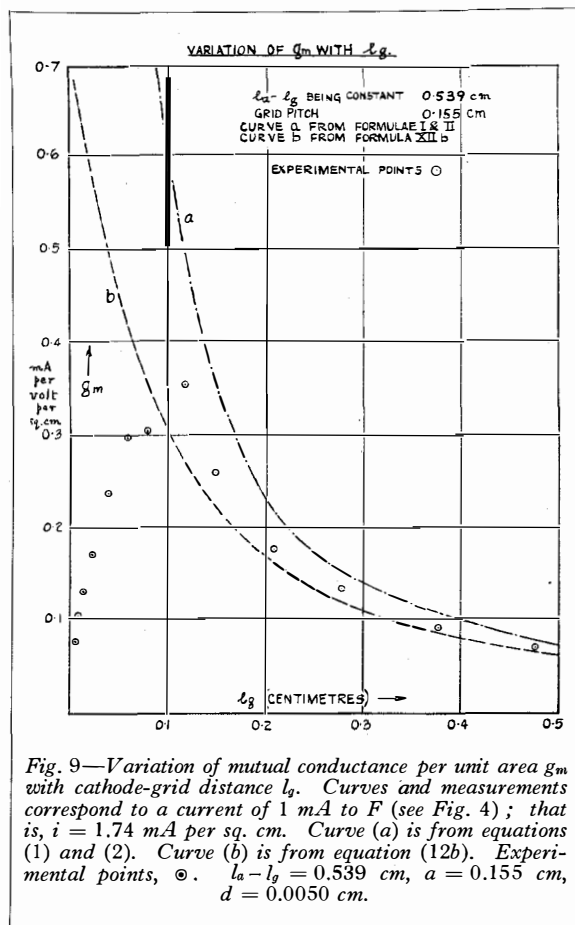

Fig. 9—Variation of mutual conductance per unit area g_m with cathode-grid distance l_g . Curves and measurements correspond to a current of 1 mA to F (see Fig. 4); that is, $i = 1.74$ mA per sq. cm. Curve (a) is from equations (1) and (2). Curve (b) is from equation (12b). Experimental points, \odot . $l_a - l_g = 0.539$ cm, $a = 0.155$ cm, $d = 0.0050$ cm.

have involved considerable constructional difficulties, and was not attempted.

The effective contact potential between the grid and the cathode was found merely by measuring the applied grid potential for which grid current disappeared (using a microammeter) when a plate current of 10 mA/sq. cm was flowing, the grid being close to the cathode. This gives the applied grid potential corresponding to the potential minimum rather than to the cathode surface itself. In the particular case of Fig. 7 the value of V_m would be about -0.2 volts. All the curves shown are corrected to the true value of cathode potential calculated in this way though the effect of the correction is very small.

The current was always small compared to the saturation current available (about 80 mA/sq. cm), and in these circumstances I_m can easily be found from the relation given by Langmuir¹⁰ (see Appendix C).

If the initial velocity correction were made to equation (1) the disagreement with the experiment would be made appreciably worse instead of better, but when applied to equation (11) the agreement with experiment becomes very satisfactory. It is usually more important to be able to calculate the mutual conductance than the current so, having shown the possibility of the latter, current calculations will not be further considered in Part I.

As with amplification factor, the mutual conductance is difficult to measure dynamically, and all measurements were made on anode current-grid voltage characteristics. In Fig. 8 is shown the comparison between theory and experiment for the variation of mutual conductance measured at $V_g = 0$ with anode distance, the grid distance being kept fixed. In this experiment the correction for initial velocities, always smaller for mutual conductance than for current, has not been made. Making the correction would raise the calculated value of g_m at any given value of anode distance by something of the order of about 2 per cent.; the two curves could not easily be shown in a reproduction. Equation (12) derived from the theory proposed above, clearly gives much better agreement than does the more frequently used equation (2).

Fig. 9 shows the variation of mutual conductance with cathode-grid distance, the grid-anode distance $l_a - l_g$ being kept constant. In this case the mutual conductance is calculated and measured for constant anode current, using equation (12b). Here it is possible to show the curve, allowing for the emission velocity correction. It can be seen that agreement is good for values of grid-cathode distance greater than the pitch, but that as soon as the grid gets closer to the cathode than this (i.e., by $l_g < a$) the experimentally measured values deviate more and more from the theory. It is particularly striking that the theory shows a continuous increase of g_m as $l_g/a \rightarrow 0$, while the experiment shows a well-marked maximum value at $l_g/a \approx 3/4$.

By a further investigation of the geometrical theory for small values of l_g/a it is possible to account quantitatively for the discrepancy, and to show why a maximum value of g_m is obtained. This investigation is described in Part II.

PART II.

DISTANCE BETWEEN CATHODE AND GRID SMALL COMPARED TO THE GRID PITCH

The formulæ worked out above are all derived upon the assumptions :

- (1) That the grid wires are thin ; the formulæ hold well as long as the wire diameter is less than 10 per cent. of the grid pitch.
- (2) That the grid pitch is itself smaller than the distances between the grid and the other two electrodes. When the distance between the grid and the cathode becomes equal to the grid pitch the formulæ will be in error by about 2 per cent. If the grid is far from the cathode the grid-anode distance may be considerably less than the grid pitch without causing serious discrepancies, as it is lack of uniformity of the field at the cathode that causes the major disturbances observable.

It has been mentioned above that formulæ already exist by means of which the penetration factor can be calculated when the grid wires are relatively thick^{3,4}. It is the purpose of this section to consider the case when the distance between grid and cathode is small. It will be assumed that the grid-anode distance is not small compared to the grid pitch ; the limitation of this will be discussed below.

The analysis is given in Appendix D ; we will give here only the principles on which the calculations were based, together with the results obtained.

In Maxwell's treatise on electricity and magnetism a function which gives the distribution of potential due to a plane charged grid of fine parallel wires is calculated. By adding to this a simple linear function of the distance from the grid plane it is possible to find the function corresponding to a grid between two conducting planes parallel to the grid plane so long as both conducting planes lie at a distance from the grid large compared to the pitch. If, however, the grid lies close to one or other of them, the field at the surface of the plane, and hence the charge upon it, is no longer uniform. This means that a linear term can no longer represent the effect of the planes upon the potential distribution. To solve the problem thus set up it is necessary to use the conception of electro-

static images. This shows that the potential distribution due to the grid and to the adjacent plane conductor is exactly the same as would be the appropriate part of the potential distribution between the grid and a similar grid, oppositely charged in the position of the optical image of the original grid in the conducting plane. Alternatively, if two similar but oppositely charged grids lie parallel to each other, with the wires of one exactly opposite to those of the other, there will be an accurately equipotential surface midway between them which can be identified as one plate of the plane triode to be considered. If a second conducting plane is at a considerable distance the addition to the combined potential functions of the grid and of its imaginary partner of a suitable linear term will adequately represent its contribution to the potential system.

In Appendix D is given the mathematical derivation of the potential function. From this an expression for the electric field at the cathode is calculated. Then it is easy to determine the value of the "electrostatic penetration factor" D_E , which represents the relative dependence of the field at any point of the cathode upon anode and grid voltages.

The general expression obtained for this is

$$D_E = \frac{\left\{ \frac{a}{4\pi l_a} \log_e \left[1 + \frac{\sinh^2 \frac{2\pi l_g}{a}}{\sin^2 \frac{\pi d}{2a}} \right] - \left(\frac{l_g}{l_a} \right)^2 \right\}}{\left\{ \frac{\sinh^2 \left(\frac{2\pi l_g}{a} \right)}{\cosh \left(\frac{2\pi l_g}{a} \right) - \cos \left(\frac{2\pi x}{a} \right)} - \frac{l_g}{l_a} \right\}} \cdot \frac{l_g}{l_a} \dots (27)$$

where x is the distance along the cathode measured from a point in the cathode directly below a grid wire.

This is interesting in that it shows no dependence on the values of anode or grid voltage, i.e., the cathode field is still at all points a linear function of V_a and V_g . On the other hand, it is no longer constant over the cathode surface, but shows a periodic variation with x , i.e., as the point considered moves along the cathode.

EXPERIMENT

It is not possible to show the variation of

penetration factor with x experimentally in a vacuum tube, as in order to do so we should have to know the distribution of current along the cathode. On the other hand, it was felt that it was necessary to get some experimental check of the formula which is of importance in the consideration of variable μ effects in close-spaced valves. It is possible to do this quite accurately using a rubber sheet model such as was originally suggested by Mr. P. B. Moon¹¹, and has been described in some detail by J. R. Pierce and others¹². A rubber sheet is stretched in a horizontal plane so tightly that it does not sag appreciably under its own weight. Then if points on it are slightly displaced vertically by suitably applied pressure any points on the free parts of the sheet will conform to the equation

$$\frac{\partial^2 h}{\partial x^2} + \frac{\partial^2 h}{\partial y^2} = 0,$$

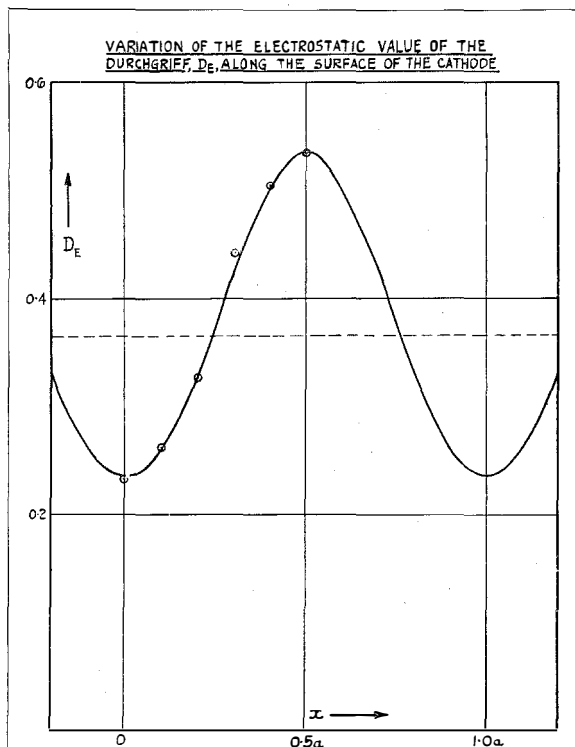

Fig. 10—Variation of the electrostatic value of the penetration factor, D_E , at a point on the cathode surface, with the distance x from a point immediately below a grid wire. The curve was calculated from equation (27) and the experimental points \odot obtained on the rubber sheet model. The dotted line shows the value of D obtained from Schottky's simple formula. $a = 29.2$ cm, $d = 0.94$ cm, $l_g = 0.4 a$, $l_a = 1.4 a$.

where h is the vertical displacement of the point and x, y are rectangular coordinates in a horizontal plane. This equation is of the same form as Laplace's equation for a potential distribution independent of the z axis under space-charge-free conditions, the displacement h taking the place of potential. We can then determine the form of the potential distribution for any system of electrodes whose geometry varies only in two dimensions by applying models of such electrodes to the stretched sheet, their displacements being proportional to the potentials normally carried by the electrodes. Clearly the slope of the free rubber sheet at any point will then be proportional to the potential gradient at the corresponding point in the electrostatic system to be investigated.

A model of a parallel plane triode was set up in this way. The "field" at the cathode was measured by means of a small piece of mirror lightly attached to the sheet very close to the edge of the cathode. This reflected a beam of light from a fixed source on to a fixed scale. It was then quite easy to measure D_E merely by raising the grid model through a measured height h_g and measuring the distance h_a through which the plate model has to be lowered in order just to bring the light spot back to its original place on the scale. This would correspond in a real valve to increasing the negative bias of the grid by a measured amount and then measuring the increase of anode potential required to maintain the cathode field at its original value.

This was repeated several times, and on plotting h_g against h_a a straight line was obtained of slope D_E . The mirror was used at several points along the cathode surface, and it was thus possible to determine the corresponding variation of D_E (the electrostatic value of penetration factor at a point on the cathode).

In Fig. 10 the full line shows the theoretical variation of D_E calculated for a particular case from equation (27) together with experimental points obtained from the rubber sheet model. The agreement may be regarded as confirmation of equation (27), though it is possible that mathematicians may rather regard it as proving the ability of the rubber sheet to deal with such problems as this. Certainly the measurements on the sheet give an extremely valuable means

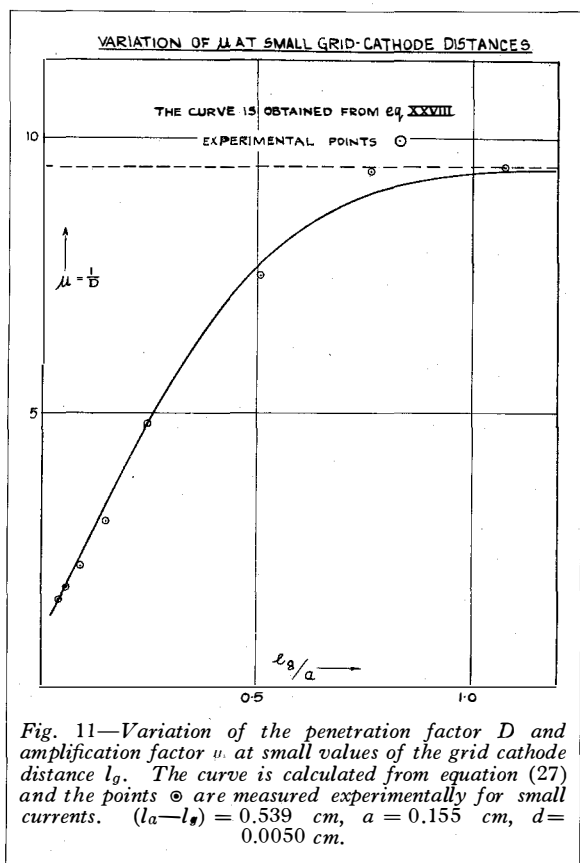

Fig. 11—Variation of the penetration factor D and amplification factor μ at small values of the grid cathode distance l_g . The curve is calculated from equation (27) and the points \odot are measured experimentally for small currents. ($l_a - l_g$) = 0.539 cm, a = 0.155 cm, d = 0.0050 cm.

of measuring amplification factors in other cases which may not be as easily calculated.

Although it was not possible to measure the variation of D_E at different points of the cathode in the experimental valve, it was possible to measure the particular value D_0 of D_E when $x = (2n + 1)a/2$, this being the value which will be obtained for very small currents, as it is clear from general considerations that the current flowing very near to cut-off will be emitted by parts of the cathode midway between grid wires.

Fig. 11 shows the corresponding variation of μ_0 with l_g/a when the distance from grid to anode is kept constant; the full line was calculated from the expression

to which expression (27) reduces when $x = a/2$, and the experimental points were obtained by plotting μ against current and extrapolating to zero.

It seems then that the expression gives accurate values down to very small values of l_g/a . For practical reasons it has not yet been tried for very small grid-anode distances; using the rubber sheet model, agreement was still obtained for

$$\frac{l_a - l_g}{a} = 0.4 \text{ and } \frac{l_g}{a} = 0.4.$$

In order to calculate anode current and mutual conductance we need to know the variation of penetration factor with current. It can be seen from Fig. 10 that D (the average value as measured) will not begin to change very much until emission has begun over an appreciable part of the cathode surface; furthermore it will be the mean value of D_E along the emitting part of the surface weighted according to the current density; this being greatest when D_E is greatest will help to prevent a rapid change of D with small currents.

Fig. 12 shows how the experimentally measured amplification factor changed with current with the grid very close to the cathode when l_g/a was 0.039. The dotted line shows the theoretical value, $\mu_0 = 1/D_0$, for zero current. Up to a current density of 10 mA/sq. cm practically no change takes place from the cut-off value μ_0 . Beyond this μ begins to go up very rapidly as $V_g \rightarrow 0$, when current begins to flow from parts of the cathode immediately below grid wires, as would be expected. The sharpness of the "elbow" in Fig. 12 depends on the values of V_a and V_g . The type of characteristic obtained at such close spacing is shown in Fig. 13. For a given value of anode current a high anode potential and large negative grid bias will give a much sharper elbow

$$\mu_0 = \frac{1}{D_0} = \frac{4\pi \left[\frac{l_g}{a} - \frac{l_a}{a} \tanh \left(\frac{\pi l_g}{a} \right) \right]}{\frac{4\pi}{a} l_g \tanh \left(\frac{\pi l_g}{a} \right) - \log_e \left[1 + \frac{\sinh^2 \left(\frac{2\pi l_g}{a} \right)}{\sin^2 \left(\frac{\pi d}{2a} \right)} \right]}, \dots \dots \dots (28)$$

than will a low anode potential and correspondingly lower grid bias. The reason for this is clear at once from consideration of the way in which the current will be distributed along the cathode surface in the two cases.

For fairly small currents then it should be possible to get a close approximation to the measured mutual conductance from equation (12), using the electrostatic value for the penetration factor in the calculation, taken from equation (28). Fig. 14 shows a curve calculated in this manner for the variation of mutual conductance with l_g , assuming that 1 mA flows in the centre section of the anode used in the experiment. The calculation is carried out for the case shown in Fig. 9. The curve shows the well-marked maximum found experimentally; this is clearly demanded by the fact that when l_g/a is small g_m is proportional to $D^{-3/2}$ and D itself is roughly inversely proportional to

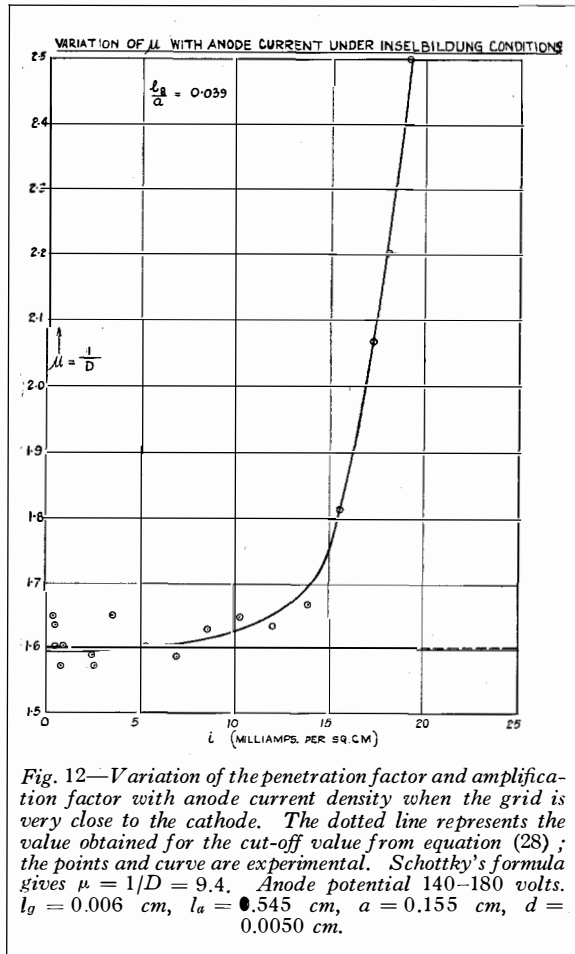

Fig. 12—Variation of the penetration factor and amplification factor with anode current density when the grid is very close to the cathode. The dotted line represents the value obtained for the cut-off value from equation (28); the points and curve are experimental. Schottky's formula gives $\mu = 1/D = 9.4$. Anode potential 140–180 volts. $l_g = 0.006$ cm, $l_a = 0.545$ cm, $a = 0.155$ cm, $d = 0.0050$ cm.

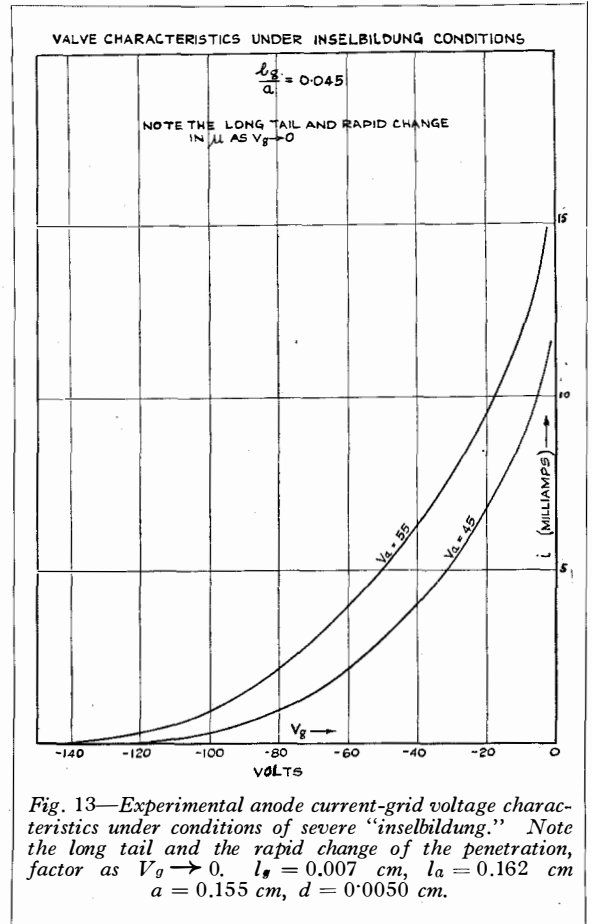

Fig. 13—Experimental anode current-grid voltage characteristics under conditions of severe "inselbildung." Note the long tail and the rapid change of the penetration factor as $V_g \rightarrow 0$. $l_g = 0.007$ cm, $l_a = 0.162$ cm, $a = 0.155$ cm, $d = 0.0050$ cm.

l_g/a^* . The values of l_g/a , for which the mutual conductance is a maximum, for constant anode-grid distance and in some other given conditions have been calculated. The calculations are not given here, as the expressions obtained are somewhat unwieldy and are of limited importance. The maxima are flat, and the exact positions found in practice depend on the emission velocities of the electrons. The experimental points shown in Fig. 9 are again put in, and it is clear that by taking account of the variation of the penetration factor with grid-cathode distance a close approximation to the measured mutual conductance can be obtained. If initial velocities are allowed for a closer approximation still can be obtained. This is clearly exemplified by Fig. 15, which was taken for a smaller value of grid-anode distance in

* This can be seen from equations (12 b) and (27); the way in which the penetration factor varies with cathode-grid distance can be seen from Fig. 11.

which the effect of emission velocity was greater and, since the saturation current was higher, more easily estimable.

We may conclude then that if allowance is made for the increase of the penetration factor at close spacings, the formulæ (11), (12) which have been developed make it possible to calculate anode current or mutual conductance to a very fair accuracy for any valve in which the electrodes may be regarded as plane, so long as the current density is not too high. Accurate calculations of the upper parts of the characteristics for close spacings have not yet been made; work is still being done on this problem. It should be noted that for valves with large amplification factors the calculated value of anode current and mutual conductance will be approximate, owing to the big difference made to the effective voltage by contact potentials, etc., unless this can be measured by observation of the grid potential at which grid current disappears. This is impossible when

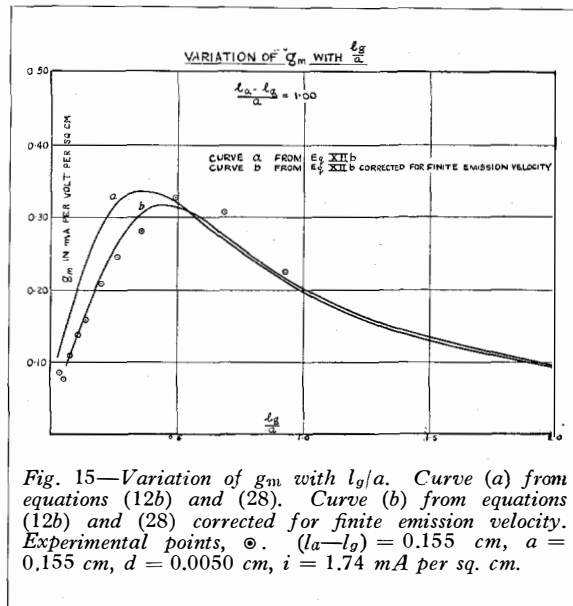

Fig. 15—Variation of g_m with l_g/a . Curve (a) from equations (12b) and (28). Curve (b) from equations (12b) and (28) corrected for finite emission velocity. Experimental points, \odot . ($l_a - l_g$) = 0.155 cm, a = 0.155 cm, d = 0.0050 cm, i = 1.74 mA per sq. cm.

it is desired to carry out the calculations in advance. It is often useful, then, to decide in advance the anode current to be used at the working point and to use the formula (12 b) :

$$g_m = \frac{26.4 \sqrt[3]{i} \times 10^{-3} \text{ amps. per volt per sq. cm}}{l_g^{4/3} + D l_a^{4/3}} \text{ when } i \text{ is in amps. per sq. cm,}$$

derived from (11) and (12 a) by elimination of V_a and V_g to determine the mutual conductance. The exact grid bias necessary is then found after the valve has been made up.

The work here described has been carried out in the Valve Laboratory of Standard Telephones and Cables, Limited, Woolwich, to whom I am indebted for permission to publish these results. I wish to acknowledge also my grateful thanks to Mr. W. T. Gibson, the Chief Valve Engineer, for the long hours which he spent in giving invaluable suggestions as to the best way of representing the results obtained; to Dr. D. H. Black, Chief of the Valve Laboratory, for his continuous advice and encouragement; to R. N. Hall and D. P. R. Petrie for their help with the work itself; and to W. R. Hindle for his skilful and accurate work in the construction of the experimental apparatus.

Finally, I would like to thank Mr. J. A. Ratcliffe for a very helpful discussion, as a result of which the theory of Part I was considerably clarified.

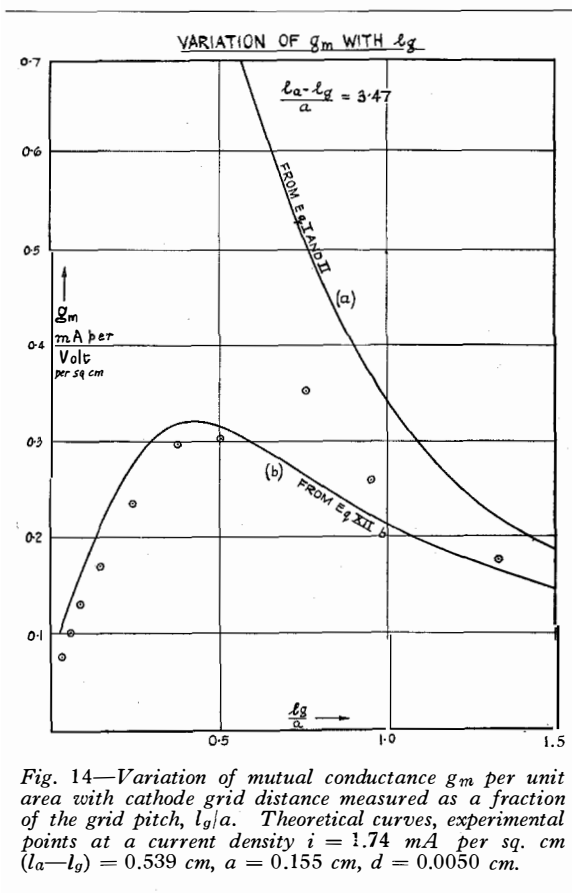

Fig. 14—Variation of mutual conductance g_m per unit area with cathode grid distance measured as a fraction of the grid pitch, l_g/a . Theoretical curves, experimental points at a current density $i = 1.74$ mA per sq. cm ($l_a - l_g$) = 0.539 cm, a = 0.155 cm, d = 0.0050 cm.

APPENDIX A

<i>Symbol.</i>	<i>Meaning.</i>
<i>a.</i>	Grid pitch.
<i>A, α, B.</i>	Used as constants.
$\beta^2.$	Langmuir's function for a cylindrical diode. See ref. ⁷ .
<i>d.</i>	Diameter of a grid wire.
$D = \frac{\partial i}{\partial V_a} / \frac{\partial i}{\partial V_g}.$	Penetration factor (reciprocal of amplification factor).
$D_E = \frac{\partial}{\partial V_a} \left(\frac{\partial V}{\partial y} \right)_c / \frac{\partial}{\partial V_g} \left(\frac{\partial V}{\partial y} \right)_c.$	Penetration factor, electrostatically calculated.
$D_0.$	The value of D_E midway between wires.
<i>e.</i>	Electronic charge.
$\epsilon.$	Base of natural logarithms.
$\eta.$	The function $\frac{e}{kT}(V - \bar{V}_m).$
$\eta_c.$	The value of η at the cathode; its value is $\log_\epsilon \left(\frac{i_{sat}}{i} \right).$ See ref. ¹⁰ .
$g_m.$	Mutual conductance per unit area in formulæ for plane electrodes; per unit length for cylindrical electrodes.
<i>i</i> or $i_l.$	Space current per unit area (plane) or unit length (cylindrical).
$i_{sat}.$	Space current density in saturation conditions.
$I_F, I_E.$	Experimentally measured currents to the centre anode and outer guard ring respectively. See Fig. 4.
<i>k.</i>	Boltzmann's Constant.
$\xi.$	The function $4(l - l_m) \left(\frac{\pi}{2kT} \right)^{3/4} m^{1/4} (ei)^{1/2} = 2L(l - l_m).$
$\xi_c.$	The value of ξ at the cathode. See ref. ¹⁰ .
<i>l.</i>	Distance of a point from the cathode.
$l_a, l_g, l_m.$	Distance of anode, grid, and potential minimum respectively from the cathode.
$l_D.$	Distance between the electrodes of the equivalent diode.
<i>L.</i>	Defined by $L = 2 \left(\frac{\pi}{kT} \right)^{3/4} m^{1/4} \sqrt{ei}.$
$\lambda.$	Charge per unit length of grid wires.
<i>m.</i>	Electronic mass.
$\mu = \frac{\partial i}{\partial V_g} / \frac{\partial i}{\partial V_a}.$	Amplification factor.
$\mu_0.$	Reciprocal of $D_0.$ (Amplification factor at cut-off).
<i>n.</i>	An integer.
$r_a, r_g, r_c.$	Radii of anode, grid, and cathode respectively of a cylindrical triode.
<i>T.</i>	Absolute temperature.
<i>V.</i>	Potential at any point.
$V_a, V_g, V_m.$	Potentials of anode, grid, and potential minimum with respect to the cathode.
<i>x, y.</i>	Rectangular coordinates with origin in the cathode, the axis of <i>x</i> being in the plane of the cathode perpendicular to the wires and the axis of <i>y</i> passing through the centre of a wire and increasing towards the anode.
$\left(\frac{\partial V}{\partial y} \right).$	The potential gradient at the cathode surface.

APPENDIX B

REFERENCES

1. J. M. Miller, *P.I.R.E.*, viii, p. 64 (1920).
2. R. W. King, *Phys. Rev.*, xv, p. 256 (1920).
3. F. B. Vogdes and F. R. Elder, *Phys. Rev.*, xxiv, p. 683 (1924).
4. F. Ollendorff, *Elektrotechnik und Maschinenbau*, lii, p. 585 (1934).
5. See, for example, Benjamin, Cosgrove, and Warren, *I.E.E.* (April 1937).
6. Child, *Phys. Rev.*, xxxii, p. 142 (1911).
7. Langmuir, *Phys. Rev.*, ii, p. 450 (1913).
8. Chaffee, *The Theory of Thermionic Vacuum Tubes*, pp. 146-7, 1st edition.
9. Dow, *Fundamentals of Engineering Electronics*, equations (82) and (111).
10. Langmuir, *Phys. Rev.*, xxi, p. 419 (1923).
11. P. B. Moon and M. L. Oliphant, *Proc. Camb. Phil. Soc.*, xxv, p. 461 (1929).
12. J. R. Pierce, *Bell Labs. Record*, xvi, p. 305 (1938); P. H. J. A. Kleynen, *Philips Techn. Rev.*, ii, p. 338 (1937).
13. W. E. Benham, *P.I.R.E.*, xxvi, p. 1093 (1938).

APPENDIX C

As a first approximation we may correct for the effect of initial velocity of emission from the cathode by measuring all distances and voltages from the potential minimum outside the cathode rather than from the cathode itself. Langmuir¹⁰ has shown that this potential minimum always exists if the current is unsaturated, and has shown how in a plane diode its distance from the cathode l_m and depth V_m can be calculated for any given current density if the saturation current density i_{sat} is known. He assumes the emitted electrons to have a Maxwellian distribution of velocities corresponding to the temperature of the cathode. For convenience he introduces the non-dimensional variables

$$\left. \begin{aligned} \eta &= \frac{e}{kT}(V - V_m), \\ \xi &= 4 \left(\frac{\pi}{2kT} \right)^{3/4} m^{1/4} \cdot \sqrt{ei}(l - l_m) = 2L(l - l_m). \end{aligned} \right\} (15)$$

The relation between η and ξ is then independent of the properties of any particular diode, and tables are given in the paper previously referred to from which either can be found if the other is known. Using suffices to indicate the points considered, we have $\eta_m = 0$, and Langmuir shows that

$$\eta_c = \log_{\epsilon} \frac{i_{sat}}{i}$$

Then
$$V_m = -\frac{kT}{e} \log_{\epsilon} \frac{i_{sat}}{i},$$

or in practical units

$$V_m = -\frac{T}{11\,600} \log_{\epsilon} \frac{i_{sat}}{i} \dots \dots \dots (16)$$

To calculate the value of l_m we use the tables mentioned above to find $-\xi_c$, since η_c can be found when i_{sat} is known.

Then
$$-\xi_c = 2Ll_m,$$

and in practical units

$$l_m = \frac{-\xi_c}{2.90 \times 10^4 T^{-3/4} \sqrt{i}} = \frac{\alpha}{\sqrt{i}} \text{ say } \dots \dots (17)$$

If voltages and distances are measured from the potential minimum then, from (11), in the plane case,

$$i = \frac{2.34 \times 10^{-6} (V_g + DV_a - V_m)^{3/2}}{[(l_g - l_m)^{4/3} + D(l_a - l_m)^{4/3}]^{3/2}} \dots \dots (18)$$

amps. per unit area.

This expression, in spite of its approximate nature, would give a very complex formula for the mutual conductance as it stands, since l_m and V_m both vary with i . If i is not a large fraction of i_{sat} , however, we can make some further assumptions before differentiating. For large values of η the rate of variation of $-\xi$ with η is small. If this is neglected we have, as in (17), that l_m is inversely proportional to \sqrt{i} , α being assumed constant for the purpose of differentiation. When i/i_{sat} becomes fairly large, α is no longer even approximately constant, but, on the other hand, the whole correction required is very small. The effect of the variation of V_m is very small except at very small currents indeed.

Then we have, from equation (18),

$$\begin{aligned} V_g + DV_a - V_m \\ = 5690 \cdot i^{2/3} \left[\left(l_g - \frac{\alpha}{\sqrt{i}} \right)^{4/3} + D \left(l_a - \frac{\alpha}{\sqrt{i}} \right)^{4/3} \right]; \end{aligned}$$

$$\begin{aligned} \therefore \frac{\partial V_g}{\partial i} \\ = \frac{2}{3} \cdot 5690 \cdot i^{-1/3} \left[\left(l_g - \frac{\alpha}{\sqrt{i}} \right)^{4/3} + D \left(l_a - \frac{\alpha}{\sqrt{i}} \right)^{4/3} \right] \\ + 5690 i^{2/3} \\ \left[\frac{2\alpha}{3} \left(l_g - \frac{\alpha}{\sqrt{i}} \right)^{1/3} i^{-3/2} + \frac{2}{3} D \alpha \left(l_a - \frac{\alpha}{\sqrt{i}} \right)^{1/3} i^{-3/2} \right], \end{aligned}$$

which gives us finally

$$g_m = g_{m1} \left[1 + l_m \frac{(l_g - l_m)^{1/3} + D(l_a - l_m)^{1/3}}{(l_g - l_m)^{4/3} + D(l_a - l_m)^{4/3}} \right]^{-1} \tag{19}$$

where g_{m1} is the value of g_m obtained from equation (12b) by replacing l_g, l_a by $(l_g - l_m), (l_a - l_m)$ respectively for a given current. The factor in the bracket is usually very close to 1.

In the case of a valve in which the electrodes are concentric cylinders the correction for initial velocities is considerably smaller¹⁰, and may therefore be neglected.

APPENDIX D

If we have a grid at a distance l_g from a conducting plane cathode we can consider the potential distribution as being that due to a pair of oppositely charged grids at $y = \pm l_g$. ($y = 0$ at the cathode). The expression

$$V = -\lambda \log_e 2 \left[\cosh \left(\frac{2\pi y}{a} \right) - \cos \left(\frac{2\pi x}{a} \right) \right]$$

represents the potential at any point (x, y) due to a plane grid of fine equidistant parallel wires with charge per unit length λ , in the plane $y = 0$, the axis of x being taken perpendicular to the grid wires and the origin being at the centre of a wire.

Then for two grids at $y = \pm l_g$ we should have

$$V = -\lambda \log_e \left[\frac{\cosh \frac{2\pi}{a} \cdot y - l_g - \cos \frac{2\pi x}{a}}{\cosh \frac{2\pi}{a} \cdot y + l_g - \cos \frac{2\pi x}{a}} \right] \dots \tag{20}$$

If we have an anode parallel to these at a considerable distance at $y = l_a$ we shall obtain the correct potential at any point by adding $By + C$ to the potential V , where B and C are constants. At the cathode, where $y = 0$, the potential then reduces to

$$V_1 = C. \dots \tag{21}$$

At the grid $y = l_g, x = d/2$ (the wire radius), and we have

$$V_2 = -\lambda \log_e \left[\frac{1 - \cos \left(\frac{\pi d}{a} \right)}{\cosh \left(\frac{4\pi l_g}{a} \right) - \cos \left(\frac{\pi d}{a} \right)} \right] + Bl_g + C;$$

$$\therefore V_2 = \lambda \log_e \left[1 + \frac{\sinh^2 \left(\frac{2\pi l_g}{a} \right)}{\sin^2 \left(\frac{\pi d}{2a} \right)} \right] + Bl_g + C, \dots \tag{22}$$

and at the anode

$$V_3 = \lambda \log_e \left[\frac{\cosh \left(\frac{2\pi}{a} \cdot l_a + l_g \right)}{\cosh \left(\frac{2\pi}{a} \cdot l_a - l_g \right)} \right] + Bl_a + C$$

$$= \lambda \cdot \frac{4\pi}{a} l_g + Bl_a + C \dots \tag{23}$$

if l_a/a is fairly large.

From the last four equations then we have

$$\left. \begin{aligned} V_g &= \lambda \log_e \left[1 + \frac{\sinh^2 \left(\frac{2\pi l_g}{a} \right)}{\sin^2 \left(\frac{\pi d}{2a} \right)} \right] + Bl_g, (a) \\ V_a &= \frac{4\pi l_g}{a} \cdot \lambda + Bl_a, (b) \\ V &= \lambda \log_e \left[\frac{\cosh \left(\frac{2\pi}{a} \cdot y + l_g \right) - \cos \left(\frac{2\pi x}{a} \right)}{\cosh \left(\frac{2\pi}{a} \cdot y - l_g \right) - \cos \left(\frac{2\pi x}{a} \right)} \right] + By, (c) \end{aligned} \right\} \tag{24}$$

where V is now measured from the cathode.

From these we can find the potential at any point by elimination of B and λ in terms of V_a and V_g . Here, however, the field at the cathode, $\left(\frac{\partial V}{\partial y} \right)_c$, is required. This is given,

from (24 c), by

$$\left(\frac{\partial V}{\partial y} \right)_c = \frac{\frac{4\pi}{a} \lambda \cdot \sinh \left(\frac{2\pi}{a} l_g \right)}{\cosh \left(\frac{2\pi}{a} l_g \right) - \cos \left(\frac{2\pi x}{a} \right)} + B \dots \tag{25}$$

Eliminating λ and B from (25), (24 a), and (24 b),

$$\left(\frac{\partial V}{\partial y} \right)_c = \frac{V_a}{l_a} + \frac{(l_g V_a - l_a V_g) \frac{4\pi}{a}}{\frac{4\pi}{a} l_g^2 - l_a \log_e \left[1 + \frac{\sinh^2 \left(\frac{2\pi l_g}{a} \right)}{\sin^2 \left(\frac{\pi d}{2a} \right)} \right]}$$

$$\times \left[\frac{l_g}{l_a} + \frac{\sinh\left(\frac{2\pi}{a}l_g\right)}{\cosh\left(\frac{2\pi}{a}l_g\right) - \cos\left(\frac{2\pi x}{a}\right)} \right] \dots (26)$$

This will vary with x until

$$\cosh\left(\frac{2\pi}{a}l_g\right) \gg 1.$$

When $l_g/a = 1$ the variation will not be very great, as $\cosh 2\pi$ is about 275, but for smaller values the variation may become considerable unless $(l_gV_a - l_aV_g)$ is small.

The relative effectiveness of the grid and anode voltages then varies along the cathode. We shall define as "electrostatic penetration factor," D_E , at any point the ratio

$$\frac{\partial}{\partial V_a} \left(\frac{\partial V}{\partial y} \right)_c / \frac{\partial}{\partial V_g} \left(\frac{\partial V}{\partial y} \right)_c.$$

The value of D_E can then be found from (26) to be given by

$$\frac{\left\{ \frac{a}{4\pi l_a} \log_e \left[1 + \frac{\sinh^2\left(\frac{2\pi}{a}l_g\right)}{\sin^2\left(\frac{\pi d}{2a}\right)} \right] - \frac{l_g^2}{l_a^2} \right\}}{\left\{ \frac{\sinh\left(\frac{2\pi}{a}l_g\right)}{\cosh\left(\frac{2\pi}{a}l_g\right) - \cos\left(\frac{2\pi}{a}x\right)} - \frac{l_g}{l_a} \right\}} \dots (27)$$

which again clearly varies along the cathode surface, giving a maximum value between two wires. In Fig. 10 is shown the form of variation

for the particular case

$$\frac{l_g}{a} = 0.4, \quad \frac{l_a}{a} = 1.4.$$

The maximum value D_0 is given by

$$D_0 = \frac{1}{4\pi} \frac{\frac{4\pi}{a}l_g \tanh\left(\frac{\pi l_g}{a}\right) - \log_e \left[1 + \frac{\sinh^2\left(\frac{2\pi}{a}l_g\right)}{\sin^2\left(\frac{\pi d}{2a}\right)} \right]}{\frac{l_g}{a} - \frac{l_a}{a} \tanh\left(\frac{\pi l_g}{a}\right)} \dots (28)$$

which for small values of l_g/a reduces to

$$D_0 = \frac{\log_e \left(1 + \frac{l_g^2}{a^2} \right)}{\frac{2\pi}{a}l_g \left(\frac{\pi l_a}{a} - 1 \right)} \dots (29)$$

The theoretical and experimental variation of D_0 with l_g/a for values of the latter less than unity is shown in Fig. 11 for a constant $\frac{l_a - l_g}{a}$

$= 1$ and $\frac{d}{a} = 0.032$. As d/a increases D_0 falls away more rapidly when l_g/a decreases, and hence when a grid close to the cathode is to be used it is advantageous to use the finest possible wire to avoid as far as possible the effects of variation with current of D .

*The Valve Laboratory,
Standard Telephones and Cables, Ltd.,
North Woolwich, E.16.*

A New Hard Valve Relaxation Oscillator*

By D. H. BLACK, Ph.D., M.Sc., F.Inst.P., F.P.S.,
Standard Telephones and Cables, Limited, London, England

RELAXATION, or saw-toothed, oscillators have been in use for a number of years, principally for providing linear time bases for cathode-ray oscillograph work. The advent of television has brought them into much more common use and in many ways the demands made upon them have become much more stringent. Fundamentally, most oscillators of this type consist in means for charging a condenser at a uniform rate and for the repeated rapid discharging of the condenser when a predetermined voltage has been built up across it. In some oscillators the process is reversed: the condenser is charged rapidly and discharged at a uniform rate; but these are essentially the same in operation. Until comparatively recently the most common method of discharging the condenser was to make use of a gas filled valve of the hot cathode grid controlled type, which discharges the condenser as soon as the required potential has been obtained. Such oscillators are still used to a very large extent, but they are open to certain objections such as instability, particularly at high frequencies. A number of oscillators using "hard" valves for discharging the condenser have been developed, some using one and others two or more valves. The circuits

to be described use hard valves and their stability of operation is extremely good, even at comparatively high frequencies.

The principle of the method can be seen in Fig. 1. The valve *D* is a tetrode whose anode is capable of emitting more secondary electrons than the number of primary electrons which reach it from the cathode. That is to say the anode has a secondary emission ratio greater than unity. A steady potential V_2 is applied to the anode through the resistance R_2 , and a negative potential V_3 is applied to the first grid of the valve through the resistance R_3 . The voltage V_1 applied

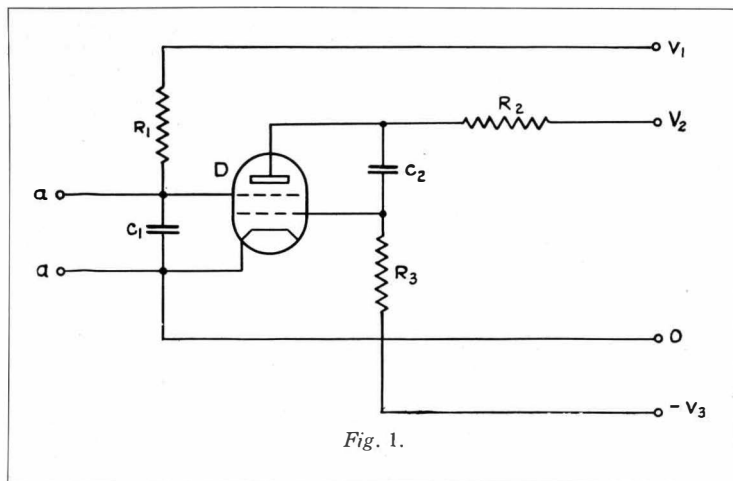

Fig. 1.

through the resistance R_1 charges up the condenser C_1 until the potential on the second grid is sufficient to cause current to flow. Some of the primary electrons will flow to the anode and will eject from it secondary electrons which will be collected by the second grid. The condenser C_1 thus commences to discharge over two paths—to the cathode and to the anode. Since the secondary emission ratio of the anode is greater than one, some current will flow from the anode through R_3 . The potential drop created in R_2 will apply a positive impulse to the first grid through the condenser C_2 . This increase in the potential of the first grid increases the current flowing through the valve, thus further increasing the current in R_2 and the potential

*Paper delivered before the Washington, D.C., Branch of the Institute of Radio Engineers, January 9th, 1939.

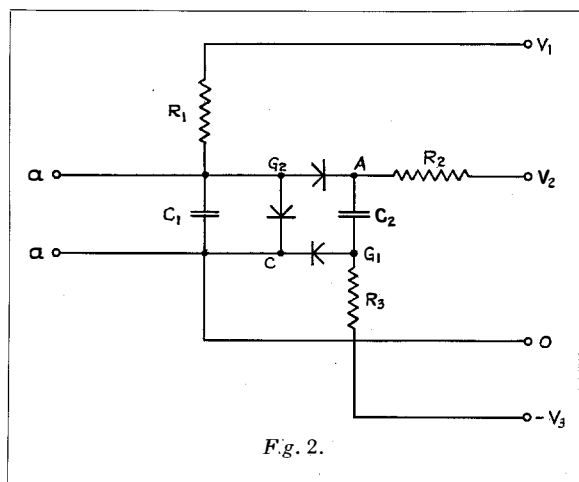

Fig. 2.

on the first grid. The process thus becomes cumulative and the discharge of C_1 rapidly takes place until the current through R_2 begins to decrease, the process then reversing and the valve returning to its non-conducting state. In practice the potential V_2 , which is usually of the order of 100 volts, may be obtained by means of a potentiometer from V_1 , while the necessary negative grid bias, $-V_3$, may be obtained by means of a bias resistor. The saw-tooth oscillations are taken off at a .

The circuit described above can be made to work tolerably well and has an extremely rapid fly-back, or discharge period. It has been incorporated in an oscillograph for providing the linear time sweep, variation in frequency being obtained by varying C_1 and R_1 , but it suffers from one drawback which under certain circumstances is rather serious. It is obvious that once the potential between the second grid and the anode becomes insufficient to withdraw the secondary electrons from the anode, the current through R_2 will decrease, so returning the valve to its non-conducting state. The action of the discharge valve depends upon the anode receiving an increase in potential, that is to say, the anode tends to rise to the potential of the second grid. In Fig. 2 the discharge valve has been shown as a series of rectifiers which indicate the directions in which the current flows through the valve. This shows that whereas the anode may easily receive a positive charge through the rectifier connecting it with the second grid, G_2 , it is not so easy for it to lose this charge which must leak away

through the resistance R_2 . As has been stated, the condenser discharges rapidly and the potential on the second grid may fall at too rapid a rate for the anode to follow it, with the result that the discharge ceases although the condenser may still have a comparatively large potential across it. Cases have arisen in which the lowest potential to which C_1 would discharge was not less than $\frac{1}{2} V_1$ even when this was 4 000 volts. The effect of this residual charge is to reduce the linearity of the oscillation to a marked extent.

A circuit depending upon the same principle of operation but which largely overcomes the defect mentioned above is shown in Fig. 3. In this circuit the positions of C_1 , R_1 and the discharge valve have been inverted; and instead of the second grid becoming positive as C_1 becomes charged, the cathode becomes more negative. As in the first case, the potential at which the valve commences to conduct is determined by the potential of the final grid, that is to say, by the relative values of R_2 , R_3 and R_4 . Once the valve commences to conduct, the operation of the circuit is similar to that for Fig. 1; but the drawback mentioned in connection with the former circuit has been largely eliminated. In this arrangement the second grid remains at a fixed potential and therefore the anode has no tendency to take up a higher potential than the second grid at any time during the discharge period. The theoretical minimum potential to which C_1 can discharge is determined by the potential necessary on the anode to give a secondary emission ratio greater than unity and

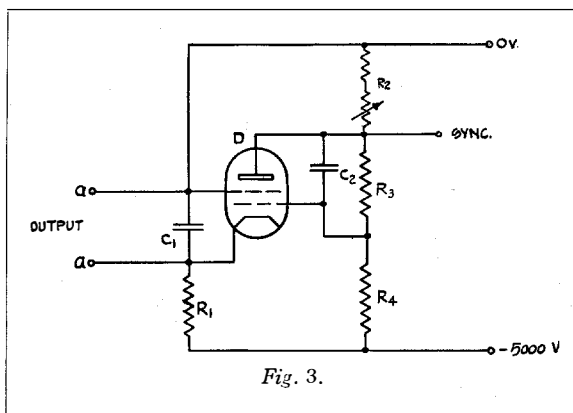

Fig. 3.

the difference in potential between the second grid and the anode which is required to withdraw the secondary electron from the anode. This minimum is not obtained in practice for a number of reasons, but it is possible to work with minimum potentials of the order of 150 to 200 volts.

While a complete mathematical analysis of the above circuit would be difficult, some of the limiting conditions can be determined in a general way. The changes in the potential of the first grid are greater than those of the cathode since, if conduction through the valve is to be maintained, the difference of potential between the cathode and grid must decrease. The change in the potential of the grid is due to the change in the potential of the anode, and the grid changes cannot be greater than the anode changes and are usually less. The main reason why the changes in grid potential are usually less than the changes in anode potential is due to the fact that if the grid becomes positive with respect to the cathode grid current will flow, so limiting any further rise in grid potential. The maximum possible change in anode potential would arise when the anode was driven right up to the potential of the second grid, but this can never be quite achieved owing to the necessity of there being a small potential difference between the two to maintain the flow of secondary electrons. The potential of the anode when conduction

starts is $-V_1 \frac{R_2}{R_0}$, where $R_0 = R_2 + R_3 + R_4$.

If the anode could be driven to earth potential, the change in potential would be $V_1 \frac{R_2}{R_0}$. Therefore the change in the potential of the first grid is always less than $V_1 \frac{R_2}{R_0}$ but may approach it under optimum conditions.

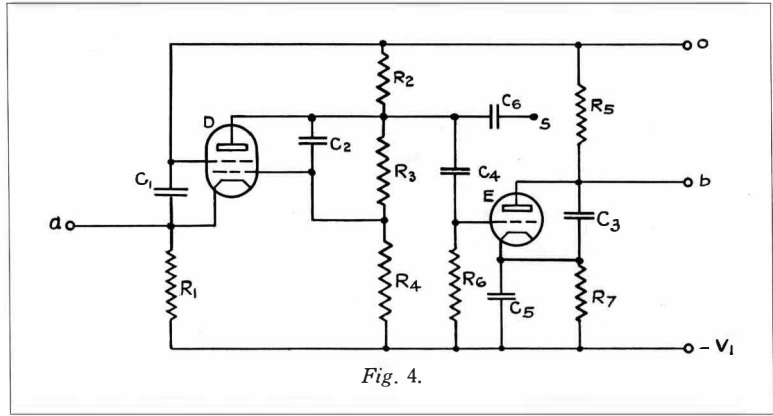

Fig. 4.

At the time when conduction begins the relationship between the potential of the cathode and that of the first grid is given by

$$V_c = \left(\frac{\mu}{\mu + 1} \right) V_{G_1} \dots \dots \dots (1)$$

where V_c is the potential of the cathode, V_{G_1} that of the first grid and μ the amplification factor of this valve at zero current. Hence the potential of the cathode is given by

$$V_c = - \left(\frac{\mu}{\mu + 1} \right) V_1 \left(\frac{R_2 + R_3}{R_0} \right) \dots \dots \dots (2)$$

As has been shown above, the maximum change in grid potential is not greater than $V_1 \frac{R_2}{R_0}$ and therefore the maximum potential to which the grid can rise is given in the extreme condition by

$$V_{G_1}' = - V_1 \frac{R_3}{R_0} \dots \dots \dots (3)$$

Assuming that when conduction finishes the cathode and first grid are at the same potential, the maximum change in cathode potential is given by

$$\begin{aligned} V_c - V_c' &= - \left(\frac{\mu}{\mu + 1} \right) V_1 \left(\frac{R_2 + R_3}{R_0} \right) + V_1 \frac{R_2}{R_0} \\ &= - \frac{V_1}{R_0 (\mu + 1)} \left(\mu R_2 - R_3 \right) \dots \dots (4) \end{aligned}$$

The actual value of the change in cathode potential, i.e., the peak swing obtainable, must be less than this for the reasons already set out, but it can be seen that for given values V_1 and R_0 the amplitude of the swing is mainly determined by the value of R_2 . The value of R_3 has a minor effect on the amplitude of the sweep

and its value is determined by the potential difference required between anode and cathode to give a secondary emission ratio greater than unity. The minimum value of R_3 can easily be seen to be given by

$$R_3 = \frac{R_2}{\mu} + R_0 \frac{V_s}{V_1} \left(\frac{\mu + 1}{\mu} \right) \dots \dots \dots (5)$$

where V_s is the potential necessary for the primary electron to give the required secondary emission ratio. This circuit is very suitable for operation at high voltages and it is sometimes convenient to operate it from the high tension supply for the cathode-ray tube.

In order to obtain freedom from the so-called trapezium distortion when operating electrostatically deflected cathode-ray tubes, it is necessary to have a balanced sweep circuit. A simple method for obtaining this is shown in Fig. 4. The left-hand portion of the diagram is the same as in Fig. 3. The right hand portion consists of a second charging circuit $R_5 C_3$ having the same time constant as $R_1 C_1$. A valve E is connected across C_3 and the negative bias on the control grid is sufficient to prevent conduction through the valve during the charging period. The change in the anode potential of valve D is also applied to the grid of E through the Condenser C_4 , so causing the rapid discharge of C_3 . With the deflecting plates of the cathode-ray tube connected to the points a and b a good balanced deflection can be obtained, and by using two such circuits with the correct time constants the line and frame sweeps for a television "raster" can be provided. Synchronizing signals are applied at S .

One of the features of this circuit is the extremely rapid discharge period or "fly-back." When working with a 405 line interlaced television system the frame fly-back takes place in half the time taken for one line, or approximately 0.25% of the charging time. The line fly-back probably takes a proportionately longer time, but that this is also very rapid was indicated by a phenomenon which will be mentioned later. For a hard valve discharge device such a rapid fly-back is unusual, the reason probably being the absence of any impedance between the condenser and the valve.

The circuit just described is very satisfactory

in many respects, but a few of the precautions which must be taken should be mentioned. Since the cathode of the discharge valve D is floating, any potential changes occurring on it are communicated to the heater. Unless these fluctuations are filtered out from the heating transformer they will also appear in other parts of the circuit, and owing to the extreme rapidity of the fly-back it is not always easy to suppress them. For this reason it is sometimes desirable to slow down the discharge by inserting resistance between C_1 and the valve.

When receiving television using such a circuit an interesting phenomenon caused by the rapid fly-back was observed. Owing to the presence of stray inductance in the discharge circuit the rapidity of the line fly-back set up oscillations during this period. The chokes in the heater circuit were not capable of filtering out these high frequency oscillations which were able to act on the modulating electrode of the cathode-ray tube. Normally, when receiving television, the modulating electrode is biased beyond cut-off during the fly-back period, but in this case the positive pulses from the oscillations were of sufficient magnitude to overcome this bias. Consequently a number of spots appeared on the cathode-ray tube screen during each line fly-back, their combined effect showing up as a number of vertical lines superimposed on the received picture. A rough calculation showed that the frequency involved could not have been less than 40 Mc/s.

As has been mentioned, the minimum potentials to which C_1 can discharge in the above circuit are of the order of 150 to 200 volts. While such residual voltages are of little importance when V_1 is not less than 1 000 volts, they may be undesirable when V_1 is only a few hundred volts. When operating electrostatically deflected cathode-ray tubes, relatively high voltages are required and the circuit of Fig. 4 is very satisfactory. Nowadays, however, there seems to be a growing tendency to use magnetically deflected tubes, in which case large deflecting currents at fairly low voltages are required, and it is very desirable to be able to operate the sweep-circuit with applied voltages of the order of a few hundred volts. For this reason the circuit shown in Fig. 5 was developed.

It will be seen that this circuit is very similar

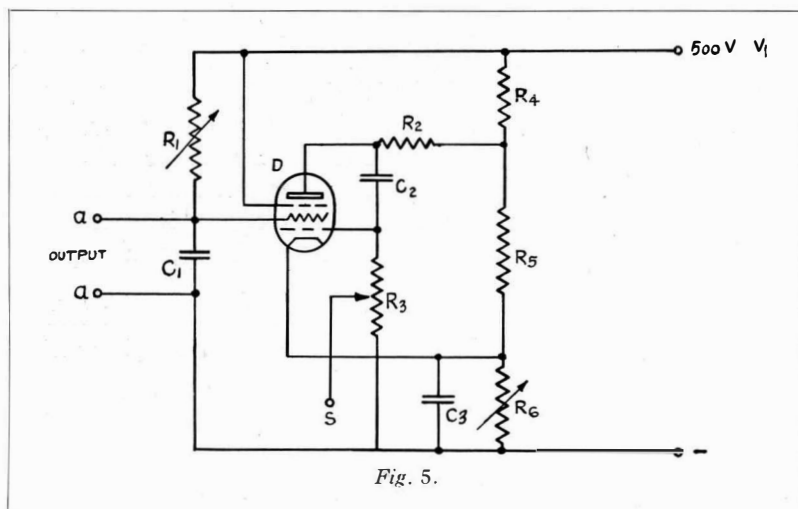

Fig. 5.

to that shown in Fig. 1, the difference being the introduction of a third grid situated between the anode and the second grid. In Fig. 5 the third grid is shown connected directly to the applied voltage. This is not essential but often convenient. It must be maintained at a higher potential than the anode. In this circuit the third grid collects the secondary electrons from the anode during the discharge period, and consequently the potential of the anode tends to rise to the potential of the third grid and not to that of the second grid. Since this potential is constant, there is no tendency for the flow of secondaries from the anode to cease as the condenser discharges before the point is reached where the current through the valve begins to decrease. Minimum potentials across C_1 may be as low as 15 to 20 volts, which is of the same order as the minimum potentials obtained when using gas-filled tubes for discharge purposes. In this arrangement the potential of the second grid may never rise above that of the anode. With V_1 having values of from 300 to 500 volts oscillations having a peak swing of 30 to 50 volts can be obtained, these being sufficiently linear for most purposes.

The valves required for the first two methods may be of a more or less conventional tetrode type, provided that the anode has a secondary emission ratio greater than unity. As a matter of fact a special tetrode for use in high voltage circuits was developed in which the second grid was well insulated and brought out to the top cap of the valve; but a commercial screen grid

valve has been successfully used. In the first two methods the total current flowing to the second grid is never less than the total emission current from the cathode, but is greater than this by the amount of current flowing through R_2 (Fig. 1). In the third method the secondary electrons emitted by the anode are collected by the third electrode. If the second grid rises to a potential above that of the anode it may collect some of the secondaries, but in general

the discharge current from C_1 only consists of the primary electrons flowing from the cathode to this grid. In a conventional type of pentode steps are usually taken to ensure that the current flowing to the second grid is only a fraction of that flowing to the anode. If such a valve were to be used in the circuit shown in Fig. 5 the discharge time would be too long, and consequently a special valve has been designed. In this valve the second "grid" takes the form of an ordinary anode with a few small holes in it. This electrode is made from carbonized nickel in order to minimize any secondary emission tendency which would slow down the discharge time. The outer anode is made of bright nickel with the inside surface sprayed with cathode coating material in order to make certain that a secondary emission ratio greater than unity will be obtained.

It has been mentioned that the pulses transmitted to the first grid of the discharge valve may be, and in fact usually are, large enough to cause grid current to flow. One result of this is that the condenser C_2 receives a charge during the discharge period, the effect of which is to make the first grid more negative than the bias potential applied to it. The charge on C_2 leaks away through the resistances in series with it during the charging period. If the time constant of the circuit associated with C_2 is too long then the potential on the first grid will be determined by the charge on C_2 and not by the applied biasing potential, with the result that the frequency of the oscillations may be largely

determined by the time constant of the C_2 circuit. One usually endeavours to obviate this by keeping the time constant of the discharge circuit well below that of the main charging circuit.

The nature of the impulses applied to the anode and to the first grid in the circuit shown in Fig. 5 are shown in Figs. 6 and 7. These are photographic reproductions of the patterns formed on a cathode-ray tube when one pair of plates is connected across C_1 , the horizontal deflection, and the other pair connected across anode and cathode or first grid and cathode. In the figures the upper pattern is taken with

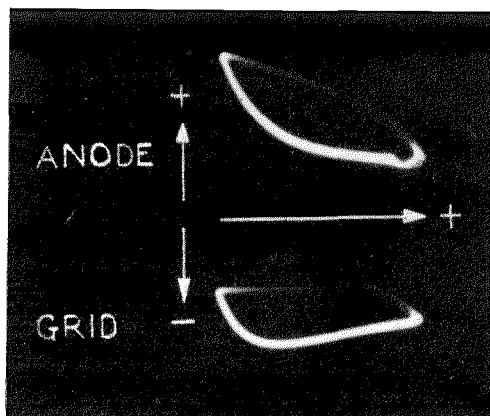

Fig. 7.

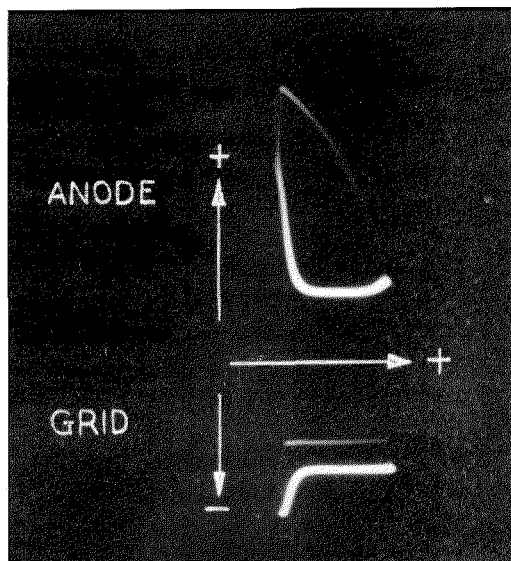

Fig. 6.

in potential over the whole of the discharge period it will be seen that the grid rises to a much lower potential and remains practically constant until the anode potential decreases when it is thrown negative. The fact that the grid remains at a constant potential is due to the fact that grid current sets in, so limiting any further increase in potential. The grid recovers from its negative potential during the charging period and returns to a uniform value well before this is completed.

Fig. 7 shows the effect of having a large time constant in the discharge circuit. It will be noticed that the anode does not return to a steady value until the charging period is nearly complete. At the same time the grid potential continues to fall over the whole of the charging period, and it is this potential fall (just as much

the anode connected to one of the vertically deflecting plates. Fig. 6 shows a normal charge and discharge cycle. During the heavy portion of the pattern the condenser C_1 is becoming charged positively until a point is reached when conduction commences in the discharge valve. At this point the potential across C_1 decreases and at the same time the anode becomes positive, as shown by the pattern sloping upwards from right to left. A sharp corner occurs when the anode potential falls sharply, conduction ceases and C_1 commences to charge once more. The anode potential continues to fall during the initial portion of the charging period, but becomes constant before its completion. Although the anode continues to increase

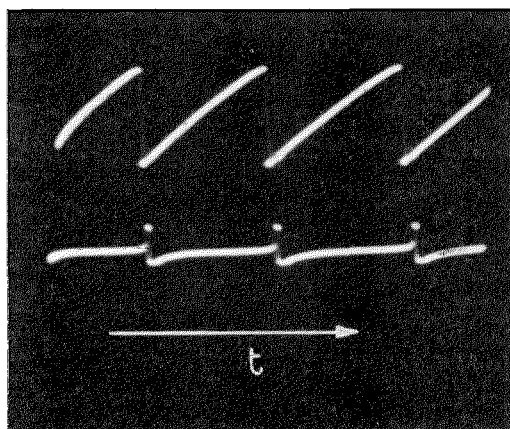

Fig. 8.

as the potential rise of the second grid) which determines the instant of discharge.

Finally, in Fig. 8, is shown the type of waveform obtained when using the circuit shown in Fig. 5. The rate of charging is not perfectly linear but, in this case, the amplitude was increased beyond the normal in order to obtain a good deflection for the photograph. In this particular case also the applied voltage was 500 volts and the peak swing was approximately 80 volts, and under these conditions a certain amount of departure from linearity is to be expected. The lower portion of the figure shows the form of the pulses applied to the first grid. The fact that the position of these pulses does not coincide exactly with the discharge periods is due to the fact that two separate exposures

had to be made and some small displacement is almost inevitable. The fly-back time shown in this figure is not of very great rapidity. Experiments are continuing with a view to its improvement, but it is quite fast enough for normal reception. Where an extremely rapid fly-back is required, the circuit shown in Fig. 3 is to be preferred.

SUMMARY

A relaxation oscillator using a single hard valve has been developed in which the positive impulses on the first grid necessary to effect a rapid discharge are derived from the flow of secondary electrons from the anode of the valve. Three modifications of the device are described, and its advantages and limitations discussed.

New "Spot Wave" Series of Commercial Radio Transmitters

THE growing congestion in the ether stresses more and more the necessity for the fullest possible utilization of available communication channels, and is leading to continual tightening by international agreement of the performance requirements of commercial radio transmitters.

The essential requirements for modern medium power commercial transmitters may be summarized as follows:—

(a) Operation on specific allocated wavelengths rather than on any wavelength selected by the operator within the band available.

This was accepted at the International Telecommunication Conferences at Cairo in 1938 as a modern development rendered possible by the application of crystal control, and was specifically endorsed in the case of airport stations by the International Commission for Air Navigation (C.I.N.A.) which at the Paris

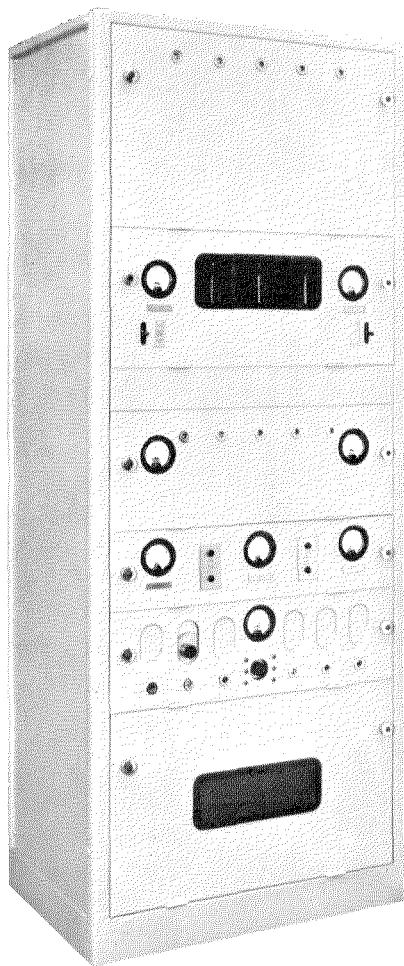

E.L.1. Transmitter (Front View).

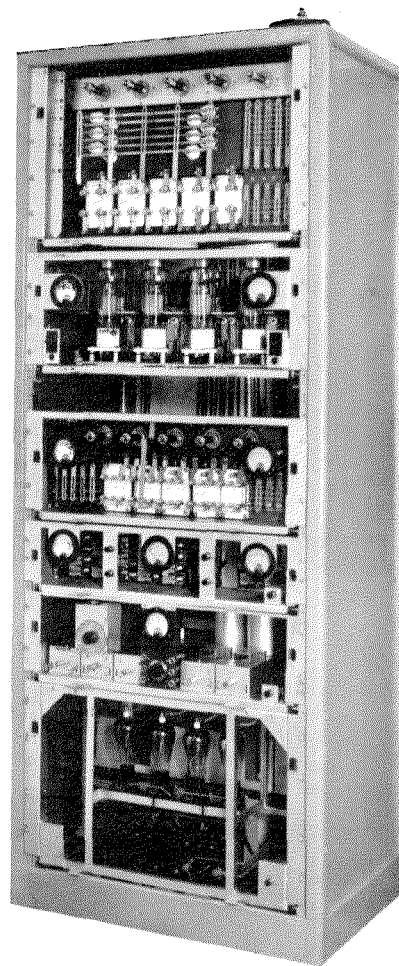

E.L.1. Transmitter (Front View with Panels removed).

TABLE I.

Transmitter Code Number	Frequency Range in Kilocycles	Number of Spot Frequencies	Power Delivered into Antenna Circuit, Watts		Inclusion or otherwise of Power Equipment	Number of Cabinet Units	Dimensions of each Cabinet in centimetres		
			C.W. Telegraph	Telephone and M.C.W. Carrier			Height	Width	Depth
E.S.1	1 780-20 000	6	500	125	Included	1	220	81	57
E.L.1	250-750*	5	500	125	Included	1	220	81	57
†E.S.2	1 780-20 000	6	400	400	Not included	1	220	81	57
†E.L.2	250-750*	5	400	400	Not included	1	220	81	57
E.S.M.1	1 780-20 000	6	500	125	Not included	1	186	81	57
E.L.M.1	100-750	5	500	125	Not included	1	186	81	57
E.S.3	1 780-20 000	6	600	300	Included	2	220	81	57
E.S.4	1 780-20 000	6	1 000	400	Included	2	220	81	57
E.L.4	250-750*	5	1 500	375	Included	2	220	81	57

* Frequency range can be extended to 100-750 kc/s by the addition of an external antenna loading coil unit.

† Power equipment may be a rectifier unit (as used in E.S.1 and E.L.1 Transmitters), mounted in unit 61 cm high, 81 cm wide and 57 cm deep.

Conference in November, 1938, laid down the actual operating frequencies for all the various types of airport ground transmissions.

(b) High degree of frequency stability and tolerance, presupposing crystal control and necessary to meet the new Cairo regulation.

(c) Rapid wave change between traffic channels and between wavebands to take care of changes in propagation conditions.

(d) Complete remote control, including wave changing, which for economic reasons must be done by the minimum number of wires. This is particularly important for airport stations.

Further characteristics which may be regarded as essential features of a modern design are :—

(e) At least four, preferably more, spot wavelengths.

(f) These should be easily changeable, and each spot wavelength should be adjustable without affecting the others.

(g) Machines should be eliminated where an A.C. supply is available.

With all the above requirements in mind, Standard Telephones and Cables, Limited, London, planned the development of a new

series of transmitters of varying powers, for both short and long wave operation, to replace the older "M" type equipments.

The members of the new series are known as "E" type transmitters, and the development has included some nine equipments, five in the short wave 15-170 metre band (1 780 to 20 000 kilocycles), and four in the medium/long wave 400-3 000 metre band (100 to 750 kilocycles). The power range is from 400-1 500 watts on telegraphy and from 125-400 watts on telephony. Table I lists the models now available.

All the sets are built on the unit system, with each equipment sub-divided, according to function, into removable units mounting in standardized steel cabinets having outside dimensions of 81 cm width and 57 cm depth. This sub-division minimizes development effort by enabling many units to be common to two or more of the series, and thus establishes a continuity of technique which simplifies operation problems. It also assists in standardization with corresponding ease of manufacture and reduction in the number of spares required for a large project. At the same time, the building of the transmitters as an assembly of units, each having a definite function and interchangeably mounted in a standardized frame, gives a degree

of flexibility of design not obtainable by other methods.

The new equipments are frequently referred to as "spot wave" sets, since they may be set up for a number of predetermined wavelengths (up to six in the short wave band, and up to five in the medium/long wave band), which may be selected either at the transmitter or at a remote controlling point by a single operation.

Each channel has a separate master oscillator and entirely separate tuning circuits (except in the long wave transmitters where there are separate tapings and individual variometer adjustments), and each spot wave can therefore easily be readjusted without affecting the others.

Electrically operated contactors are used for wavelength selection. This system has been chosen in preference to mechanically linked switches on account of the greater flexibility which it offers and of the much greater ease in initial installation and maintenance.

Crystal control is an essential feature but provision is made for valve oscillator control for emergency use or when the final operating frequencies have not yet been allocated.

The majority of this series of transmitters have self-contained power equipment for operation from alternating current mains, using H.C.M.V. valve rectifiers. They can, however,

be supplied with machines to work from a D.C. supply where necessary, e.g., when required for marine use.

The transmitters may be controlled either locally or remotely. The local control system operates by direct connection between a control unit and the transmitter, using some twenty inter-connecting wires. With this system the operator may (a) select the system of transmission, CW, MCW or phone, (b) select the operating frequency, (c) switch the supplies "ON" and "OFF" and (d) key or modulate the transmitter. The above operations may be performed from a distance not greater than 100 yards.

The remote control system functions over two telephone pairs, and enables the equipment to be controlled from distances as great as 25 miles. In addition to performing the same operations as the short distance control system, check back facilities and an order wire service are included. Telephone dial control is used, embodying the latest technique and safeguards of supervisory remote control systems.

The new equipments possess advantages of transmission quality, ease of operation and control, minimum maintenance and general flexibility, which may well be regarded as setting up a new standard in commercial transmitter design.

Rectifier Power Plant for Transmission Systems

By R. KELLY, B.Sc., A.R.C.Sc.I.,

Standard Telephones and Cables, Limited, London, England

EDITOR'S NOTE.—*An article on "Some Industrial Applications of Selenium Rectifiers" was published in the April, 1939, issue of this Journal. The present article describes the Selenium Rectifier Power Plant which has been developed for use in Communication Transmission Systems, particularly at Carrier Terminals and in unattended Repeater Stations.*

AT carrier terminals and repeater stations, steady and reliable supplies of filament and plate voltage for amplifiers and oscillators are required, and for many years it has been apparent that dry rectifier equipment, operated from alternating current mains would be an attractive alternative to constantly running motor-generator sets. The development of dry rectifiers of reasonable size, i.e., of the selenium type, and of reliable electrolytic condensers for smoothing out the large ripple voltages associated therewith, has made these rectifiers suitable for application in practically all types of communication transmission systems.

VOLTAGE REGULATION

To ensure the best performance and longest life of the valves used in Transmission Systems, the voltages supplied to them must be maintained within about one per cent. of the nominal values; and, to obtain this close control, it is necessary to take into account the fluctuations to be expected in the mains supply and the inherent regulation of the rectifying equipment over a wide range of load currents.

In the mains supply, experience shows that in some countries variations of ± 10 per cent. of the nominal voltage are to be expected, and the load voltage delivered by a dry rectifier is roughly proportional to the applied alternating current voltage. The resistance of a dry rectifier in the conducting direction decreases as the current increases but, even so, the inherent voltage regulation from no load to full load is of the order of 15 per cent. for a single-phase rectifier. Moreover, for the satisfactory operation of communication systems, the rectifier ripple voltage must be smoothed to a very small fraction of the load voltage. Smoothing is accomplished by means of series

choke coils and shunt condensers; but, since the size and cost of choke coils increase very rapidly as their resistance decreases, it is not economical to provide a smoothing circuit having a voltage regulation from no load to full load of less than about 4 per cent.

The integrated effect of these variables, assuming limiting values for the mains voltage, is such that the load voltage would vary over a range of about 40 per cent. if no voltage control were provided.

In the past, control has been achieved by the use of resistances in series with the load, but with this method the widely varying conditions encountered involve considerable power loss and, consequently, low efficiency over a large part of the range. Furthermore, when planning power equipment it is usual to allow for future load extensions; thus this low efficiency, which obtains at loads less than 100 per cent. of full load and at mains voltages above the minimum, means that the power equipment must be operated during a large part of its life under uneconomical conditions. A typical value for the efficiency of a power unit having dissipative control is 50 per cent. at full load, decreasing as the load decreases, and varying with fluctuations of the mains voltage.

An alternative to purely dissipative control is a combination of the latter with adjustment by coarse tapings on the mains transformer, using contactors or commutators with special locating devices. While tending to improve the efficiency on low load, this method is both expensive and cumbersome.

EQUIPMENT WITH NON-DISSIPATIVE CONTROL

To overcome the disadvantages of dissipative control, a new type of automatically controlled

equipment operating from 3-phase, 50 p : s mains has been developed. It was initially designed to meet the requirements of 12-channel carrier systems, but it is now used in all types of communication transmission systems.

Separate rectifier equipments are used for filament and plate supplies. The output voltages are maintained constant within ± 1 per cent. of 21.7 volts and 130 volts, respectively, and the rectifier units operate with high overall efficiency under varying conditions of load and mains supply voltages.

Each rectifier unit consists essentially of a regulating transformer, the rectifier proper, and its associated smoothing circuit. The secondary voltage of the transformer is regulated by means of automatic control gear operated under the control of a sensitive "high-low" voltage relay connected across the output terminals of the unit. Since control is initiated from the D.C.

output, this type of regulation automatically compensates for fluctuations in the mains voltage and load.

Normally, a standby supply for each rectifier unit is provided by an oil engine generator set which furnishes the necessary power via the filter circuit in the unit, should the rectifier shut down. A small floating battery—10 cells for the L.T. unit, and 60 cells for the H.T. unit—remains connected across the output of each rectifier unit to supply the load during the time that the engine takes to start and run up to speed. This battery also assists in smoothing and in damping out small fluctuations.

CONSTRUCTION

Each rectifier unit is mounted in a cubicle comprising an angle-iron framework having a sheet steel front panel upon which the control apparatus is mounted, the sides, back and top

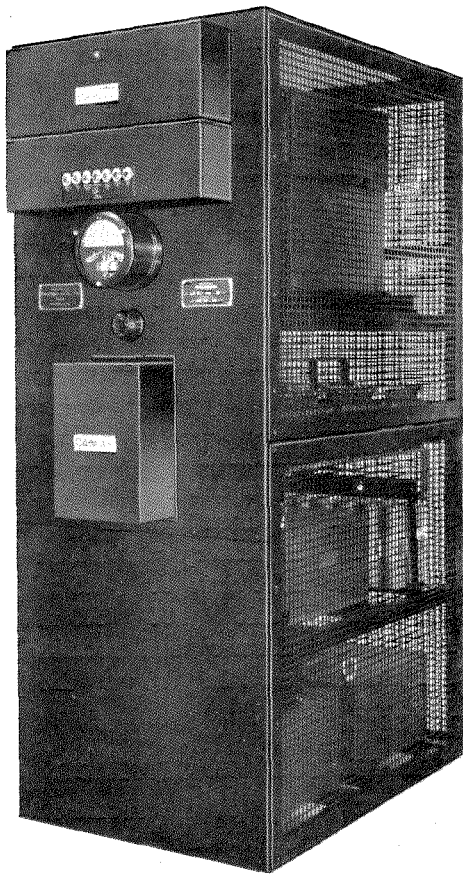

Fig. 1—Front View of Rectifier Unit : Output 150 A, 21.7 V $\pm 1\%$ —all covers fitted.

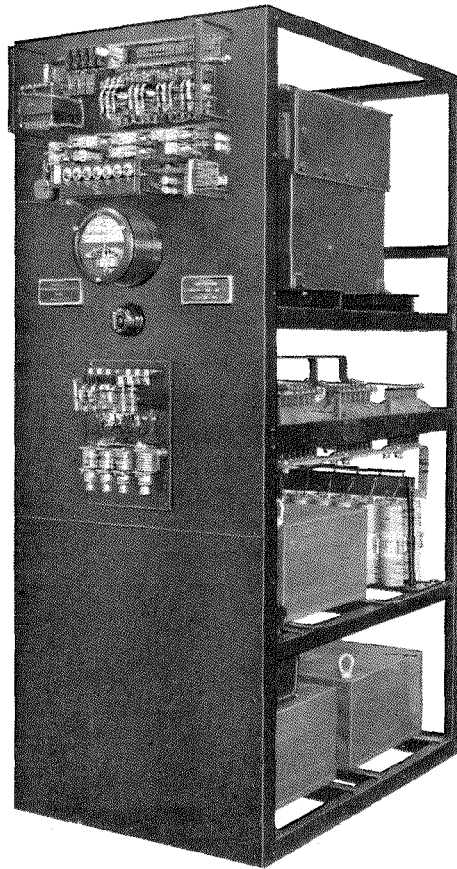

Fig. 2—Front View of Rectifier Unit : Output 150 A, 21.7 V $\pm 1\%$ —all covers removed.

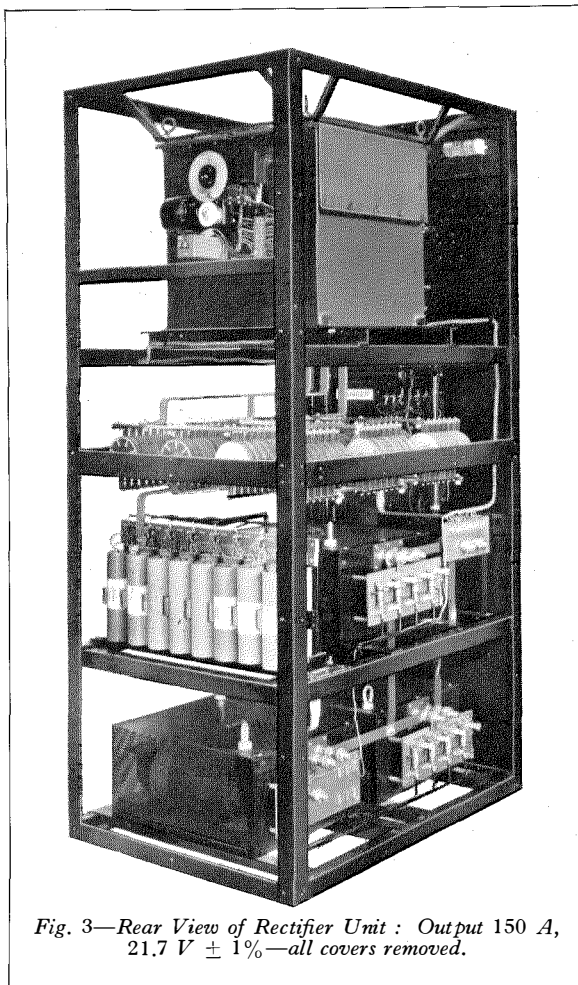

Fig. 3—Rear View of Rectifier Unit : Output 150 A, 21.7 V \pm 1%—all covers removed.

being protected by perforated sheet steel. The accompanying illustrations show views of a 150 amp., 21.7 volt filament supply unit. The plate supply unit, which delivers 7 amps. at 130 volts, is similar in appearance, and of the same width and height, the chief differences between the two types of unit being dictated by the power handling capacity of the component parts.

FRONT PANELS

With the exception of certain resistances, the front panels of the L.T. and H.T. units are identical, and carry the following components :

- (1) Main control switch ;
- (2) Three-pole mains contactor ;
- (3) "High-Low" voltage relay ;
- (4) Transformer control apparatus ;
- (5) Phase failure relay ;

- (6) Indicator and alarm lamps ;
- (7) Auxiliary fuses.

The mains contactor is fitted with one overload trip per phase and an overload trip for the D.C. output of the unit ; these trips are of the dashpot type and are adjustable.

The control apparatus for the variable transformer includes a time delay relay for shutting down the equipment should the control gear fail to correct the voltage within a specific period.

MAIN EQUIPMENT

The variable transformer, rectifier and filter circuit are housed within the cubicle.

The transformer is double-wound, star-delta connected, with an earthed shield between the primary and secondary windings, the output voltage being continuously variable over a very wide range by means of a large number of tapings on the primary windings. The transformer is oil-cooled and mounted in a steel tank together with the brushgear. On the outside of the tank is mounted a control panel carrying the brushgear motor with its associated clutch mechanism, and "high-low" contacts which prevent the control gear from over-running in either direction.

The rectifier is a 3-phase, bridge-connected, air-cooled, selenium type dry rectifier. No fan is employed to cool the rectifier, so that the possibility of fan failure and increased running costs at light loads are obviated.

The smoothing circuit is a two-stage filter of conventional design, employing chokes and dry electrolytic condensers. The ripple voltages at full load do not exceed the following figures, when measured by means of a psophometer with a C.C.I.F. telephone weighting network, and with the floating battery connected :—

- | | |
|--------------------------|---------|
| Filament or L.T. unit .. | 0.5 mV. |
| Plate or H.T. unit .. | 5.0 mV. |

A smaller transformer and rectifier, also mounted within the cubicle, supply the power for the control gear.

AUTOMATIC VOLTAGE CONTROL

The output voltage of the rectifier unit is controlled by a sensitive but robust moving-coil "high-low" relay, so adjusted that its contact arm floats when the output voltage lies within \pm 1 per cent. of the normal value. An increase

or decrease in voltage beyond the allowable limits causes the relay to make either its "high" or "low" voltage contact. Either of these contacts when made operates a pilot relay which in turn controls a magnetic clutch connecting the motor to the brushgear, and at the same time closes the motor circuit. Thus the brushgear is driven in the direction required for restoring the output voltage to normal.

When the contact arm of the "high-low" relay is again floating, the pilot relay is de-energized, thereby releasing the clutch and applying a brake which stops the revolving brushgear immediately; the motor is also switched off and brought to rest by means of a friction brake.

In the "high-low" relay circuit, a novel feature has been introduced to prevent chattering of the contacts, and to restore the contact arm to the mid-position upon correction of the load voltage. When contact is made on the "high" side, the operation of a relay reduces the amount of resistance in the circuit of the "high-low" relay winding; this causes an increased current to flow through the winding, thereby producing an improved contact. When contact is broken, the resistance is increased, thereby reducing the current flow and causing the contact arm to return to the mid-position. On the "low" side, the resistance is increased when contact is made and decreased when contact is broken.

ALARM AND STANDBY CIRCUITS

In the event of mains or phase failure, the rectifier unit immediately shuts down, a non-urgent alarm is given, and a circuit is completed for the automatic starting of the standby engine generator set which, besides supplying the load, recharges a small starting battery. When the mains supply has been restored to normal, the brushgear is driven to the position of minimum output and the starting battery is completely recharged before the mains contactor can be reclosed. Thus when the unit is again switched on, excessive output cannot occur, and the possibility of an overload trip which might shut down the unit completely is avoided.

Failure in any component part of the rectifier unit, such as the variable transformer, control motor, "high-low" relay, or an overload trip,

completes an urgent alarm circuit and shuts down the unit; the latter cannot be put back into service until a push button key has been operated. An urgent alarm is also given in the event of a condenser failure.

The localization of faults is facilitated by alarm lamps mounted on the front panel.

EFFICIENCY

The overall efficiency of these rectifier units from the 3-phase supply to the smoothed output at full load and at half load is greater than 70 per cent., and is practically independent of variations in supply voltage, the efficiency at half load being higher than at full load. The power factor is in excess of 0.9.

ALTERNATIVE TYPES OF EQUIPMENT

As an alternative to the standby engine generator set, these rectifier units may be operated in conjunction with a wide variety of auxiliary apparatus, depending on local conditions and on the requirements of the particular system with which they are to be used.

For example, in place of the engine generator set, a standby battery—12 cells for L.T. supply, or 72 cells for H.T. supply—and an auxiliary rectifier unit can be provided. In the event of failure of the normal supply, the standby battery is automatically connected via an automatic regulating resistance, and continues to float the small battery and supply the load. Upon restoration of the normal supply, the change-over switch does not operate until a certain predetermined voltage on open circuit is obtained at the output of the regular rectifier unit, corresponding to the correct voltage at normal load. The auxiliary rectifier unit automatically recharges the standby battery, and serves as a standby for the transformer and rectifier in the regular unit.

Another type of equipment comprises a rectifier unit and large floating battery capable of supplying the load when necessary. The battery is automatically charged while floating, and an automatic regulator associated with the battery maintains the load voltage within the prescribed limits.

Where floating batteries are equipped, there is no break in the supply to the load during change-over from the rectifier unit to the

standby apparatus. Change-over to a standby engine generator set takes place in 10 seconds so that, for systems in which an interruption of this order can be tolerated, equipments can be supplied without floating batteries.

ADVANTAGES

The main advantages to be derived from the use of these equipments are summarized below :

- (1) The overall efficiency under all conditions of load and mains voltage is relatively very high and is independent of mains variation. Moreover, the efficiency at half load is greater than at full load.
 - (2) The heat developed is exceptionally low inasmuch as regulation is not carried out by heat dissipation, so that the equipment can be mounted in a more confined space.
 - (3) The rating of the rectifiers is limited to the power required to feed the load and is not increased by any considerations which, as with dissipative control, might be involved if the control device were located between the rectifier and the load. In some cases, the latter arrangement might cause an increase in the rating of nearly 50 per cent.
 - (4) The effective load range is unlimited,
- whereas the resistance range of a dissipative regulator must be limited for purely economic reasons. It is possible to cover mains variations of ± 10 per cent., and load variations from full to no load, even when allowance is made for ageing of the rectifiers.
- (5) The impedance of the circuit is lower than in an equipment having a similar smoothing circuit but employing a dissipative regulator mounted in the smoothing circuit. This is important in the case of telegraph equipments.
 - (6) Above a certain rating the initial cost of the rectifier unit falls rapidly below that of a unit employing dissipative regulation, since the cost of the control circuit remains constant—the only variables being the transformer, rectifier and smoothing circuit.
 - (7) In all circumstances, the rectifier unit starts up with a low load voltage which increases to the correct value, thus preventing damage to valve filaments, etc. Furthermore, large surge currents due to the charging of condensers and the excess load taken by cold filaments are obviated and there is therefore no need to provide extra protection on the fuses or circuit breakers.

Tie Line Problems in P.A.B.X. Design

By R. T. RINGKJOB,

Bell Telephone Manufacturing Co., Antwerp, Belgium

1. INTRODUCTION

1.1 General

DURING approximately the past five years the demand for private telephone installations has increased conspicuously, due largely to improvements in the facilities incorporated therein and in the performance achieved by such equipments.

The efficiency of the P.A.B.X. operator has been more than doubled by the design of high speed, super-service key sending positions, which enable the operator to extend incoming city calls without delay, whilst retaining complete supervision of the progress of the connection.

A facility that has proved highly useful to P.A.B.X. subscribers is that of making internal information calls on established city connections whilst the city party waits. Eventually, the city party may be transferred to any other P.A.B.X. station. Unprecedented rapidity and flexibility are thus achieved.

Special services now available are quite impressive, and include such important facilities as code calling, conference calls, priority, executives' rapid call senders, watchman's round control, fire call service, supervisory sets, etc. The utilization of these auxiliary services is becoming more and more common.

With improved switching technique, it has become possible to group scattered offices or plants into separate, private P.A.B.X. networks with full automatic intercommunication.

This phase of P.A.B.X. development has evoked considerable interest, as is evidenced by many inquiries from the field relating to the interworking of new or existing installations. It was felt, consequently, that a discussion of some of the most frequently encountered P.A.B.X. interworking problems might be useful. The purpose of this article is, therefore, mainly informative.

1.2 Definition of a Tie Line

A tie line is generally understood to be a direct connection between two private telephone exchanges, whereas a direct connection between a P.B.X. and a city exchange or toll office is referred to as a junction (English usage) or trunk (American usage).

From an operating viewpoint, this distinction is sufficiently well defined to avoid confusion. From a design viewpoint, a tie line is a connection on which the setting of a selector at one end is controlled by impulses received from the other end whereas, on a junction connection, the selector at the P.A.B.X. end is set by indications from the local P.A.B.X. attendant.

It sometimes happens that a customer desires all incoming tie line calls to be handled by an attendant. In such cases the tie line may be provided with regular junction circuits, junction operating methods being employed.

Junctions may utilize two or three wires between exchanges. Tie lines invariably require only two. All types of tie lines are arranged for two-way working.

1.3 Types of Tie Lines

For the present purpose it is convenient to classify the various types of tie lines under the following headings:

Tie lines between two automatic P.B.X.'s;

Tie lines between an automatic and a manual P.B.X.;

Tie lines with 50-cycle signalling;

Tie lines interconnecting a group of P.A.B.X.'s;

Special tie lines.

Before outlining the principles underlying the design of the various types, the fundamental problems of tie line working will be briefly considered.

2. INTERWORKING PROBLEMS

The questions that require consideration when

designing a tie line may be summarized as follows :

(a) *Seizure of Tie Line*

A calling P.A.B.X. station must be able to connect itself to a free tie line, either automatically or with the aid of an attendant.

The fact that a tie line is connected must be indicated. A second dialling tone from the distant end is usually employed.

(b) *Transmission of Dial Impulses*

After seizure of a tie line, the P.A.B.X. station (or the attendant) must be able to select a distant party by dialling that party's regular number.

(c) *Conversation*

On a tie line connection the normal subset efficiency of the two P.A.B.X. parties should be maintained independently of the length or other characteristics of the tie line. It is, consequently, preferable to provide for local transmitter feeding at each end of the tie line.

The local feeding bridge also serves the purpose of retransmitting the dial impulses. This retransmission is necessary in practice due to the fact that every stepping arrangement has a maximum limit for the tie line resistance. If a calling P.A.B.X. station were given metallic through connection to the distant end, the maximum permissible value of the resistance of the station line plus the tie line would be determined by the operating margins of the distant end stepping relay, and could in general not be made greater than the maximum station line resistance. Such an arrangement, obviously, would operate satisfactorily only on very short tie lines, and would consequently be of limited practical utility.

It can safely be said that the combined supervisory (transmitter feeding) and stepping (impulse repeating) bridge is now an essential feature in tie line design.

(d) *Release*

After conversation all circuits must be released when the two parties have hung up.

If the tie line connection be established by an operator, the termination of a call must be signalled to her so that she can release the connection manually.

(e) *Control from Distant End*

It will, of course, sometimes happen on an automatic tie line connection that the calling or called station hangs up with a certain delay. This may result in inconvenience unless special precautions are taken.

Let us assume that the calling party at P.A.B.X. "A" hangs up first. If the tie line circuit at "A" were released immediately, another station at "A," making a tie line call at that moment, might seize it and might find another person on the line. A similar condition might apply if the called party, by hanging up first, immediately freed his end of the tie line.

In order to avoid the confusion that might arise from such occurrences, the circuits must be arranged for simultaneous release at both ends. This means that reciprocal control must be provided between the two ends of a tie line, ensuring the holding of either end until the other is freed.

The application of the above requisites to practical cases will now be described in some detail.

3. TIE LINES BETWEEN TWO AUTOMATIC P.B.X.'S

3.1 Introduction

At first sight it might appear that the easiest way to provide intercommunication between two P.A.B.X.'s would be to connect a tie line as a subscriber's line at each end. A regular substation number would be assigned for this service, and a local link would always be engaged on both outgoing and incoming tie line calls.

Such a scheme would solve problems of seizure, conversation, release and control from the distant end without modification of the local link circuits. The retransmission of dial impulses, however, would involve rather serious difficulties.

A standard P.A.B.X. link is not arranged for such retransmission of impulses. It would, therefore, be necessary to provide means for metallic through-connection in the link whenever a tie line number is dialled, and the tie line circuit itself would contain the combined feeding and impulse repeating bridge together with the necessary supplementary relays.

As an alternative, the standard link might be

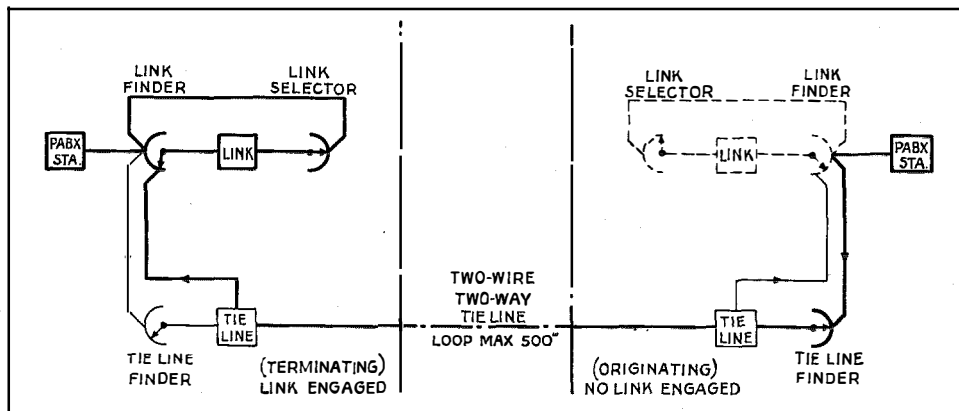

Fig. 1—Simple Tie Line—function Diagram.

arranged for retransmission of impulses. The tie line circuit then would only include certain accessory relays.

Such modifications in the local link would, obviously, only be operative on outgoing calls. At the incoming end the link would receive the retransmitted dial impulses the same as from a local subscriber; thus, no difficulties would arise.

The provision of metallic through-connection or retransmission of impulses in the local link would require at least two or three relays per link. Although these relays would only be furnished when required, space and wiring would have to be foreseen for all links. It would be necessary also to arrange the local link for one additional single digit call (per tie line direction) with group hunting facilities over the tie lines. These modifications would, however, necessarily result in an undesirable increase in the cost of a standard P.A.B.X.

Another disadvantage of using a local link for outgoing tie line service would be a reduction in the total subscribers' line capacity. If, for instance, a regular 50-line P.A.B.X. were equipped with 5 tie lines, only 45 substations could be connected.

Because of considerations of economy and standardization it has been deemed advisable to abandon any switching scheme based on engaging a link on outgoing tie line calls. The only other practical alternative is to terminate the tie line in a separate switch at each end, the

arc of the switch being multipled to the subscribers' lines. Thus the tie line may be seized by any station for outgoing calls.

Incoming calls, in any case, may be handled over the local link provided the tie line resistance does not exceed a specific value which, for 24-volt P.A.B.X.'s, is about 500 Ω . This is the maximum resistance which permits the link stepping relay to function satisfactorily. If the tie line resistance be above 500 Ω , a separate selective device must be provided in the tie line itself.

The above considerations have led to the adoption of two types of tie line between automatic P.B.X.'s, the "simple" and the "self-contained" tie lines, respectively.

3.2 Simple Tie Line

The simple tie line utilizes a local link for incoming calls. It does not, consequently, include any selective device.

At each end the tie line is forked, one branch ending in the tie line finder used for outgoing calls, and the other branch terminating on the arc of the local link finders as a regular subscriber's line. The complete substation multiple is connected to the tie line finder arc. Since the link line finder arc may be of a larger capacity than the selector arc, the connection of simple tie lines does not necessarily reduce the capacity of the P.A.B.X.

The junction diagram of a simple tie line network and the working principle of the circuits

are shown in Figs. 1 and 2, respectively. On the basis of these sketches the switching procedure will be briefly explained.

(a) Seizure of Tie Line

The P.A.B.X. substation removes the handset, receives dialling tone from the local link and dials the digit assigned for tie line calls, say "8." This causes a free tie line finder to hunt for and pick up the calling line, whereafter the link, which was temporarily engaged, is released.

The substation is now connected to the instepping relay I_r of the tie line (Fig. 2). Eventually relays D_r , C_r and C_r operate; and, through the back contacts of A_r , battery is connected to the "a" wire and ground to the "b" wire.

This results in the energization of the high resistance line relay, B_r , of the tie line at the distant end and causes a free local link finder to search for the tie line, after which relay C_o_r operates, disconnecting the line relay. The distant link supervisory relay is now energized from battery and ground at the originating end, and a dialling tone is sent back to the calling party, indicating that dialling may start.

(b) Transmission of Dialling Impulses

The dial impulses are received on relay I_r , and retransmitted by relay A_r to the distant link's supervisory relay.

It will be seen that several factors influence the impulse transmission. On a regular subscriber's line this influence is confined to the following variables: calling station's dial speed, length of subscriber's line, voltage of P.A.B.X. power supply and adjustment of the stepping relay.

In addition, the simple tie line scheme includes the following possible variations: adjustment of relays I_r and A_r , length of tie line and difference of ground potential between the two P.A.B.X.'s. All may occur in any combination so that it would be practically impossible to avoid serious distortion of the dial impulses without eliminating some of the variables.

A ready means of improving conditions is illustrated by the provision of the arrangement of Fig. 2. The distant link supervisory relay is not operated over a loop, each winding being in an independent circuit via the back contact of

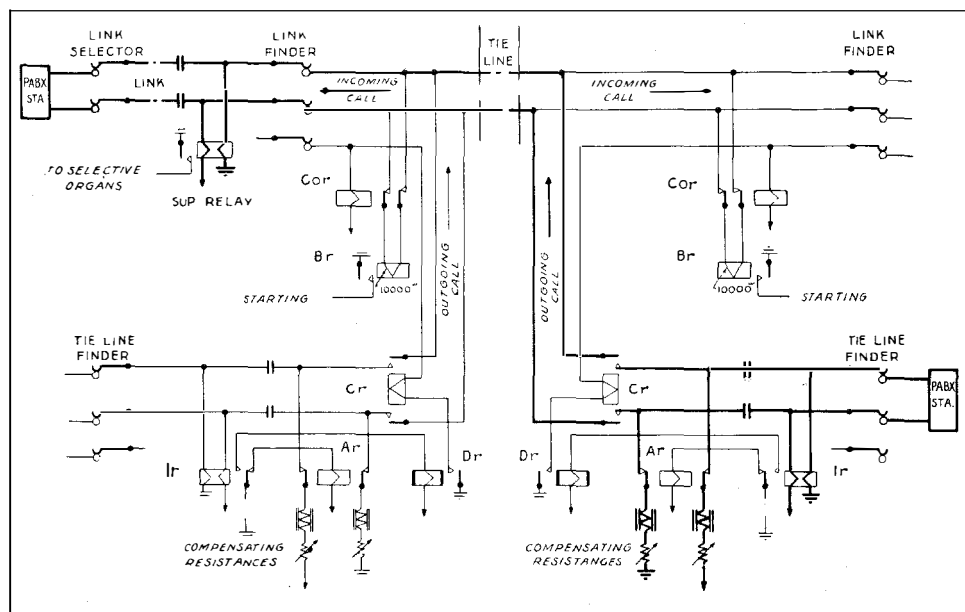

Fig. 2—Simple Tie Line—Switching Principle.

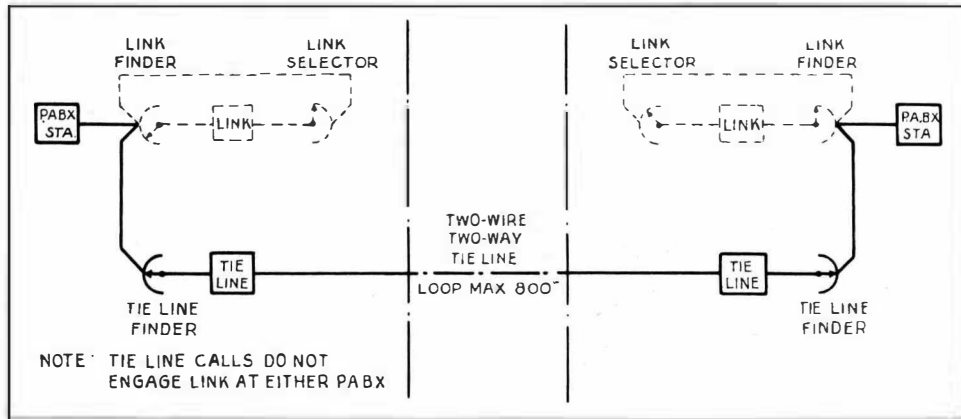

Fig. 3—Self-contained Tie Line—Function Diagram.

relay *Ar*. The influence of ground potential variations is thus eliminated.

The compensating resistances added in the circuit are adjusted once and for all so as to make the total tie line loop resistance approximately 500 Ω. Differences in tie line resistance are consequently overcome.

Due to the fact that the distant link's supervisory relay has an independent circuit for each winding, it would be theoretically possible to make the tie line resistance double that of the station line resistance. If the latter loop is 500 Ω the tie line should work with 500 Ω in each wire, or with a total of 1 000 Ω. Because of the retardation coils in series with the compensating resistances, and the distortion caused by the retransmission of impulses, it is, however, not possible in practice to guarantee more than 500 Ω tie line loop resistance in 24-volt systems.

(c) Conversation

The talking paths are shown in heavy lines in Fig. 2. It will be seen that the tie line introduces an additional bridge with about the same transmission loss as a local link.

(d) Release

Generally considered, a local P.A.B.X. link works on the principle of "front release," i.e., the originating party controls the connection. When he hangs up, the circuits are released and both parties are freed. If the called party hangs up first, nothing happens, and his line remains engaged.

Since the simple tie line makes use of a link on an incoming call, it follows that the originating party controls the connections at both ends. This tie line is, therefore, also subject to "front release."

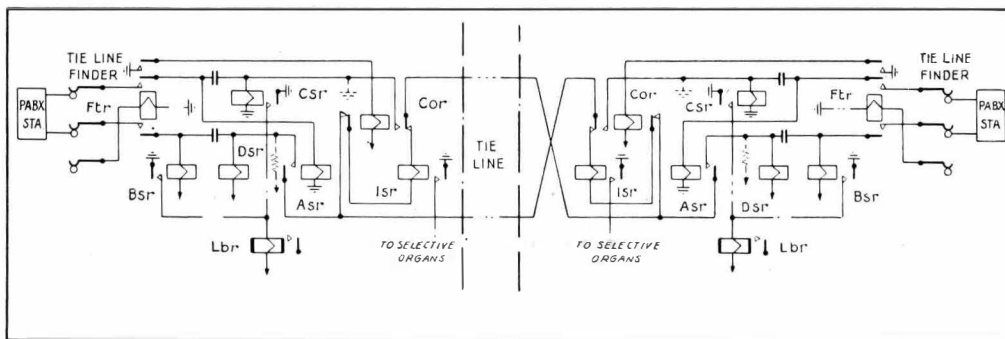

Fig. 4—Self-contained Tie Line—Switching Principle.

(e) Control from Distant End

Since a simple tie line connection is held at both ends until the originating party hangs up, no special measures are required to prevent wrong connections.

(f) Scope

The use of a simple tie line is recommended where the tie line resistance is within the permissible limits and where the number of tie lines is not sufficiently great for the traffic volume to influence the number of local links.

3.3 Self-contained Tie Lines

The characteristic of this type of tie line is that it does not make use of a local link on either outgoing or incoming calls, the necessary selective mechanisms being included at each end of the tie line. The tie line finder has a dual function ; i.e., on outgoing calls it acts as a line finder and, on incoming calls, as a selector. Since this type of tie line is independent of a local link, it is termed a "self-contained" tie line.

Fig. 3 illustrates a typical junction diagram and Fig. 4 the working principles of the circuit. The switching procedure is as follows :

(a) Seizure

The P.A.B.X. station removes the handset, receives dialling tone from the local link and dials the digit assigned for tie line calls, say, "8."

This causes a free tie line finder to hunt for and pick up the calling line, whereupon the link, which was temporarily engaged, is released.

The substation is now connected to the supervisory relays *Asr* and *Bsr*. Relay *Cor* is already energized. Relay *Asr* closes the loop for the distant end instepping relay *Isr*, which energizes and prepares the circuit for the reception of dial impulses. A dialling tone is sent back to the calling station.

(b) Transmission of Dial Impulses

The dial impulses are retransmitted via a front contact of *Asr* and received on relay *Isr*, which retransmits them to the digit receiving switch or other selective mechanism.

At the first interruption of each digit the circuit conditions are changed, a direct ground being connected to the "a" wire and a non-

inductive resistance with battery to the "b" wire, as indicated in dotted lines on Fig. 4. All inductance is consequently removed from the dialling loop during dialling in order to improve the stepping conditions.

This stepping arrangement operates satisfactorily over tie line loops up to 800 Ω resistance on 24-volt systems.

(c) Conversation

Both instepping relays are disconnected during conversation. The circuit conditions are exactly the same at both ends so there is no discrimination between outgoing and incoming calls.

(d) Release

Conditions at both ends being the same, it is logical to arrange for "last party release," i.e., the circuits at both ends are held busy until the last party hangs up.

(e) Control from Distant End

The "last party release" implies a reciprocal control of the two ends of the circuit. This control is established in the following way :

Each end has a slow releasing relay *Lbr* which controls the release of the circuit. Relay *Lbr* is kept energized by both *Bsr* and *Csr*, i.e., relays which are controlled by both the calling and the called parties. If, for instance, one station hangs up, its *Bsr* relay releases, but *Lbr* is kept energized by *Csr*, which receives battery from the "b" wire at the other end (coil *Dsr*) as long as the second party has not hung up. By reciprocal control, wrong connections are avoided.

(f) Scope

The self-contained tie line is recommended where the tie line resistance exceeds 500 Ω and where the tie line traffic is so heavy that it would be necessary to increase the number of links if simple tie lines were used.

4. TIE LINES BETWEEN AN AUTOMATIC AND A MANUAL P.B.X.**4.1 Introduction**

A tie line between an automatic and a manual P.B.X. includes two distinct elements, i.e., the termination at the P.A.B.X. end, and the jack circuit at the manual board.

The design of the latter depends not only on the P.A.B.X. end tie line, but also on the type of manual switchboard and the features of the manual cord circuit. Consequently, numerous variables are encountered, involving a great many possible solutions.

The following description will be limited to discussion of some typical cases frequently met with in practice.

(a) *Tie Line Termination at Automatic P.B.X.*

In principle a manual tie line may terminate at a P.A.B.X. in three different ways, viz., as a regular subscriber's line, as a simple tie line or as a self-contained tie line. The choice of these alternatives depends on factors which will be explained in detail subsequently.

(b) *Jack Circuits on Manual Board*

A jack circuit must fulfil certain general conditions in order to operate satisfactorily with a distant automatic switchboard of any kind:

- (a) The seizure of a tie line at the distant end must result in the lighting of a lamp or the operation of a drop at the manual board. This can be accomplished either by connecting battery and ground to the line, or by sending out ringing current. The jack circuit must consequently cater for one of these conditions.
- (b) When the operator answers, the calling lamp must be extinguished and a loop must be provided over the tie line in order to trip the ringing or close the distant end battery bridge.
- (c) A clearing signal must be received by the manual operator.
- (d) If the operator originates the tie line call, she must be able to dial the P.A.B.X. station number, since this is the main criterion for tie line operation. The dial may be connected over an individual dial key per tie line, or it may be inserted in the cord circuit by throwing a common dialling key.

(c) *Supervision*

The question of supervision has always presented certain difficulties in manual tie line operation.

On local battery (magneto) manual switch-

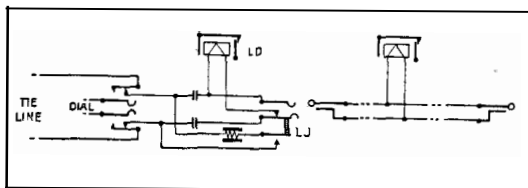

Fig. 5—Tie Line Termination on Local Battery Board.

boards, where the clearing signal is given by means of ringing current, only one clearing drop is provided per cord (Fig. 5). Both stations can "ring off."

On tie line connections ring-down clearing signals from both sides can only exceptionally be provided. Usually only the manual P.B.X. station can "ring off" on a tie line connection.

On central (common) battery boards, a clearing lamp is associated with each of the two plugs of the cord. These lamps are usually lit over the back contact of the respective supervisory relays to a ground connected to the sleeve of the subscriber's jack (Fig. 6). On a station to station connection, double supervision is consequently obtained. On a tie line connection, however, double supervision cannot be given except in particular cases, as explained hereinafter.

The different types of tie lines are described below in some detail.

4.2 *Subscriber's Line as Tie Line*

At the automatic P.B.X. the tie line terminates as a regular subscriber's line.

(a) *Seizure*

The P.A.B.X. station dials the regular tie line number (1, 2 or 3 digits). The link sends out ringing current, which operates the line drop, *LD*, in the distant jack circuit (Fig. 5), if the board is of the magneto type, or the ringing relay, *Rr*, if the board is of the common battery type (Fig. 6). In the latter case, the ringing relay locks and lights the calling lamp *CL*.

(b) *Operator Answers*

When the operator inserts the plug, the drop is restored (or the calling lamp is extinguished), a retardation coil being bridged across the tie line in order to trip the ringing (Figs. 5 and 6).

The operator establishes the connection with the wanted party in the usual way.

(c) Operator Originates a Tie Line Call

The operator inserts the plug in the tie line jack, and, by closing the loop, originates a call in the P.A.B.X. When dialling tone is received, the operator throws the dial key and sends the wanted station's regular number.

(d) Supervision and Release

On tie lines of this kind there are no practical means of obtaining clearing signal from the automatic P.B.X. party.

If the operator originates the call, the P.A.B.X. link is held under control of the manual operator, due to the "front release" feature previously mentioned. If the called P.A.B.X. party hangs up first, his line is not freed, and no indication is given to the jack circuit.

then be used, giving clearing signals from the P.A.B.X. end.

(e) Control from Distant End

On calls originated by the manual operator no control is necessary since the operator controls the release of the P.A.B.X. connection.

On calls originated by a P.A.B.X. subscriber, the tie line is liberated from the time the calling party hangs up until a new link is picked up. During this interval no control is provided, and if the tie line should happen to be picked up by another P.A.B.X. subscriber during this period, the new call is liable to be lost unless the operator listens in before removing the plugs.

(f) Scope

This type of tie line is used when the tie line resistance is within the limits of a regular

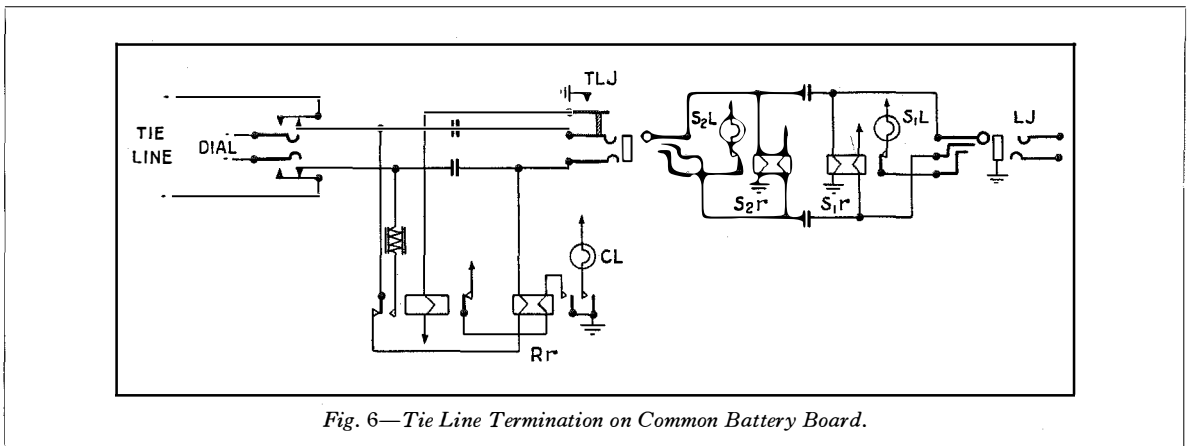

Fig. 6—Tie Line Termination on Common Battery Board.

If a P.A.B.X. party originates the call, the link is freed when the calling party hangs up; but, since the jack circuit maintains a loop over the tie line, a new call is originated in the P.A.B.X. A free link is picked up and is kept engaged until the operator removes the plug.

On a tie line, which terminates as a subscriber's line at a P.A.B.X., only single supervision can consequently be given. Subscribers at common battery boards, of course, retain the facility of calling in the operator by flashing the switchhook.

It may happen that the manual operator has to extend calls from a distant P.A.B.X. via junctions to a central office of any type. If proper supervision is not given on such junctions, a P.A.B.X. subscriber's line is unsuitable as a tie line. A self-contained circuit should

P.A.B.X. subscriber's line, and when one or a few tie lines are sufficient. If more than one tie line is required, they should be connected to a P.B.X. hunting group, if available.

4.3 Self-contained Tie Line

If the termination at the P.A.B.X. is made in the form of a self-contained tie line, a local link is not engaged on either outgoing or incoming calls.

(a) Seizure

The P.A.B.X. station dials the single digit assigned to the tie line and waits until the operator answers.

When the self-contained tie line has been attached, ground is connected to the "a" wire and battery to the "b" wire (Fig. 4); relay R_r

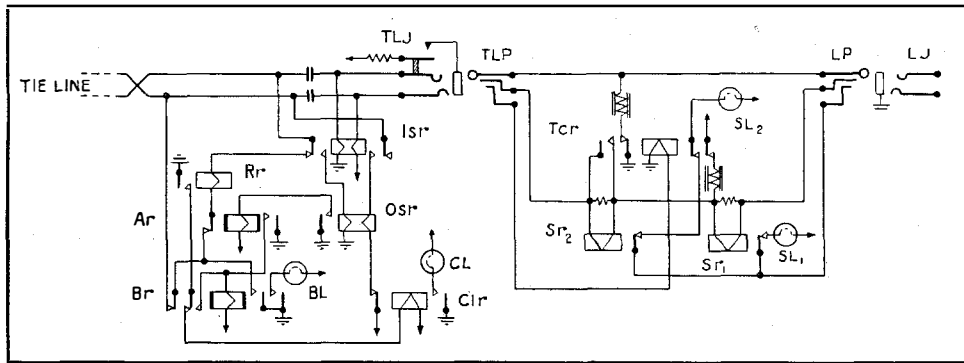

Fig. 7—Self-contained Tie Line to Common Battery Board.

in the jack circuit (Fig. 7) is operated. The calling relay CIr in turn becomes energized and lights the calling lamp CL . This sequence is typical of a jack circuit in a common battery switchboard.

If the manual board is of the local battery type, the P.A.B.X. tie line must give a ring-down signal to operate the tie line drop. Accordingly, the self-contained tie line may be modified as shown in Fig. 8. When the tie line is picked up, the feeding relay S_1r energizes and in turn operates the slow acting relays Ar and Lbr . In the meantime, the ringing relay Rr (fast operating, slow releasing) energizes and sends ringing current out on the line. The duration of this ringing impulse is sufficient to operate the drop in the jack circuit.

(b) Operator Answers

When the operator on a common battery

P.B.X. plugs in, the lamp is extinguished, the stepping relay Isr operates, and the Osr relay is connected across the tie line. The line relay falls off, and the two slow acting relays Ar and Br become energized (Fig. 7).

Plugging in on a local battery board has the effect of bridging the tie line by a retardation coil, thereby operating the distant end stepping relay S_2r (Fig. 8).

(c) Operator Originates a Call

By inserting a plug in the tie line jack, the operator closes the tie line loop, which prepares the distant tie line for the reception of dial impulses. A dial tone is sent back to the operator, who throws the dial key and sends the wanted number.

In the jack circuit of Fig. 7 the impulses are retransmitted by the stepping relay Isr , whereas in Fig. 8 the impulses are received directly on

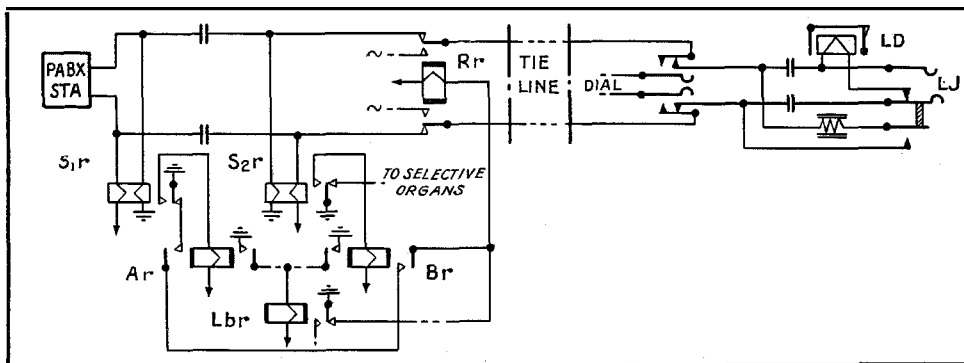

Fig. 8—Self-contained Tie Line to Local Battery Board.

relay S_2r in the distant self-contained tie line.

(d) *Supervision and Release*

Fig. 7 illustrates a typical manual C.B. cord circuit with common transmission bridge as used, for instance, on the Bell Telephone No. 7551 switchboard. This cord is arranged to give metallic through-connection on junction and tie line calls by the operation of the Tcr relay from a battery connected to the sleeve of the tie line jack.

Feeding on tie line calls is accomplished from the jack circuit combined supervisory and stepping relay Isr . One of the cord supervisory relays Sr_1 is connected in the manual subscriber's loop to give clearing signals to the operator. Clearing signals from the P.A.B.X. end are not provided.

If the operator clears first, the busy lamp remains lit.

If the P.A.B.X. party releases first, nothing happens, since the Osr relay is kept energized from ground on the "a" wire at the P.A.B.X. end.

In the local battery tie line it is easy to provide for a short clearing signal from the P.A.B.X. end (Fig. 8). If the P.A.B.X. party hangs up first, relay S_1r falls off and the Rr relay operates before the front contact of Ar is opened.

(e) *Control from the Distant End*

The self-contained tie lines shown in Figs. 7 and 8 are both arranged for control from the distant end, i.e., if the P.A.B.X. station releases first, no other P.A.B.X. party can pick up the tie line before the operator has cleared the connection. In Fig. 7, relay Osr establishes this control in connection with relay Csr in Fig. 4. In Fig. 8, the S_2r relay maintains the P.A.B.X. end engaged until the operator removes the plug.

(f) *Scope*

The self-contained tie line is used when the tie line resistance exceeds the maximum permissible resistance of a subscriber's line, and also if a plurality of tie lines, due to heavy traffic, is required.

4.4 *Simple Tie Line*

The justification for the design of a simple tie line between two automatic P.B.X.'s has

been indicated previously. It will be recalled that the simple tie line is provided with an impulse retransmitting arrangement, due to the difficulty of giving this facility in the local link circuit.

On tie lines to manual boards there is no need for such a retransmitting arrangement at the P.A.B.X. end. The simple tie line thus has very little scope in connection with manual P.B.X.'s and is very seldom used.

A regular subscriber's line, as described in section 4.2, can in most cases replace the simple tie line. An adapter circuit for long lines may eventually be added in case the tie line resistance should exceed the maximum permissible substation loop, thereby allowing the use of tie lines up to 900 Ω (24-volt systems).

4.5 *Long Manual Tie Lines*

It sometimes happens that a P.A.B.X. is connected to a distant manual P.B.X. or attendant's board by tie lines of up to 2 000 Ω resistance. The usual tie line arrangements, already described, would not be suitable in such cases.

It is nevertheless possible to employ direct current impulsing even under such circumstances, due to the particular method of operation on a manual tie line. Actually, only one person (the manual P.B.X. operator) dials over such tie lines, and dialling takes place in one direction only. Consequently, no great difficulty is encountered in inserting the dial directly in the tie line in order to avoid retransmission of impulses. Furthermore, by compensating the tie line to the maximum permissible loop resistance, the stepping relay at the P.A.B.X. end functions under the most favourable conditions.

Fig. 9 shows a skeleton tie line jack circuit with an individual dialling key, which permits dialling out on the tie line without retransmission of impulses.

The jack circuit to Fig. 7, interworking with a self-contained tie line to Fig. 4, would not work over more than about 800 Ω (24 volts at both ends). The jack circuit to Fig. 9, however, would work over 1 000–1 100 Ω . It is, moreover, possible to go even further by increasing the dialling and feeding battery in the jack circuit. This can be done by inserting dry cells

between the common battery and the feeding coil and dial key, as indicated by B in Fig. 9. Since the number of tie lines usually is small, and the resistance high, the current consumption of the extra dry cell battery will seldom exceed 50–60 milliamperes.

By adding 10 dry cells in series it is thus possible to work over tie line resistance up to 1 800 Ω . If the tie line terminates on a 48-volt attendant's board, the resistance may be increased to 2 000 Ω without jeopardizing the limits of safe operation.

The addition of an extra dry cell battery has given quite satisfactory results in practice, but the method is recommendable only in connection with manual tie lines.

5. TIE LINES WITH 50-CYCLE SIGNALING

5.1 Introduction

Reference has been made above to the factors influencing the transmission of dial impulses over different types of tie lines. Accordingly, a maximum permissible tie line resistance has been determined for the various arrangements utilizing dialling impulses in the form of interruptions of direct current. This resistance varies from 500 to 2 000 Ω .

All tie lines mentioned so far have a direct current passing over both wires from the moment the tie line is engaged until it is released after conversation. Any signals passed over the tie line consist of interruptions of the direct current.

The great majority of problems relating to interworking between P.A.B.X.'s can usually

be solved by means of one of the direct current tie line arrangements already described. There are cases, however, where direct current signaling methods cannot be employed, as for instance :

- Where the tie line resistance exceeds the limit of D.C. operation ;
- Where the tie lines are equipped with repeaters ;
- Where the tie lines make use of phantom circuits ;
- Where the tie lines must be terminated in repeating coils for any other reason, such as where carrier current remote control systems are superimposed on the telephone system.

In all these cases alternating current signalling methods must be adopted.

The type of 50-cycle signalling system, as developed by the Laboratories of the Bell Telephone Manufacturing Company, Antwerp, for use in long distance dialling networks, has also been adapted for use on P.A.B.X. tie lines. This system has been described previously¹ ; but, for the sake of completeness, the details of a typical 50-cycle tie line will be briefly indicated.

Fig. 10 shows the working principles of a 50-cycle self-contained tie line.

5.2 Self-contained Tie Line

The arrangement comprises two parts, viz., sending and receiving.

¹ "A Field Trial of 50-Cycle Signalling on Toll Lines," by William Hatton, *Electrical Communication*, October, 1936.

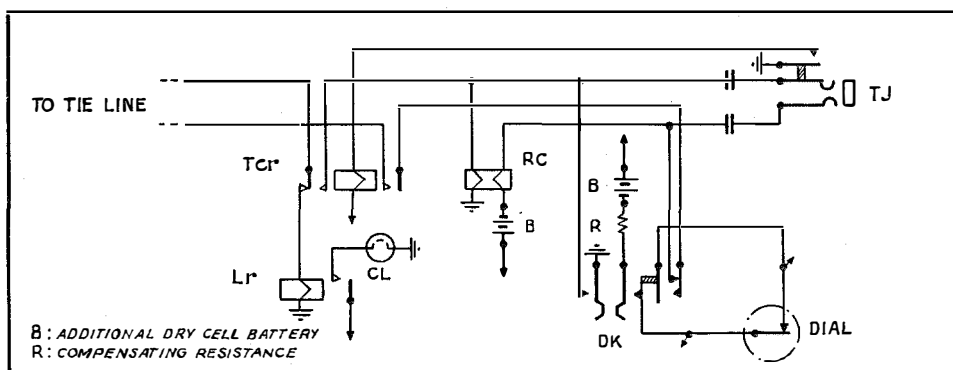

Fig. 9—Long Manual Tie Line.

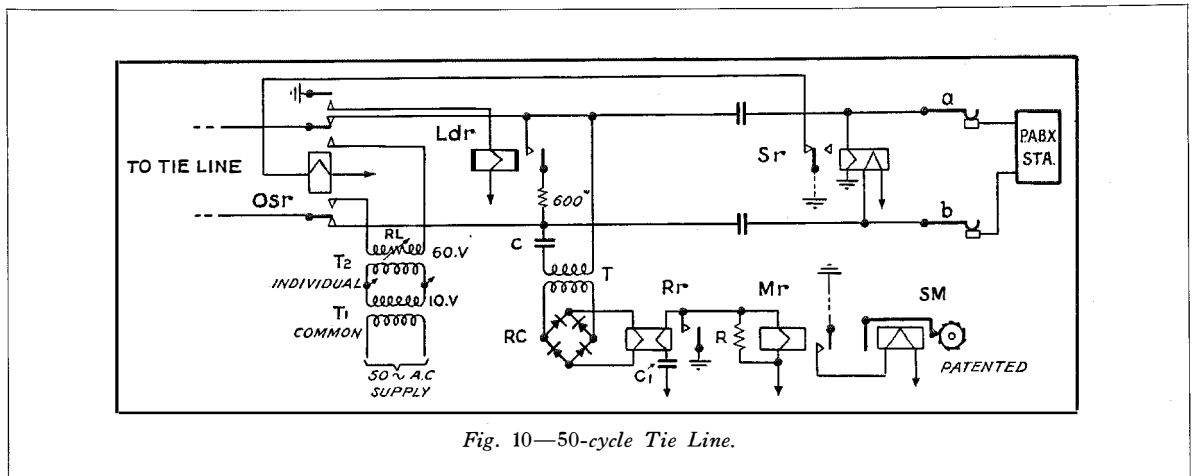

Fig. 10—50-cycle Tie Line.

(a) Sending Equipment

The sending part consists of the 50-cycle supply transformers, T_1 and T_2 , and the outstepping relay Osr .

Transformer T_1 is common per P.A.B.X., while T_2 is individual per tie line. By providing individual transformers the interference between adjacent circuits, due to current in the 50-cycle supply leads, is practically eliminated.

Relay Osr works from the back contact of the local stepping relay Sr , which in turn is operated from the P.A.B.X. station dial.

The direct current impulses produced by the dial are consequently converted into a series of 50-cycle current impulses sent out on the line via the front contacts of relay Osr .

The sending voltage is adjusted by means of the variable resistance RL .

In order to prevent the capacity discharge of the cable reaching the receiving unit, a slow releasing relay Ldr is included. This relay holds during the impulse train of each digit and short-circuits the line by a $600\ \Omega$ non-inductive resistance, which absorbs the cable discharge each time Osr closes its back contacts.

(b) Receiving Equipment

The receiving unit comprises a transformer T with condenser C , a rectifier Rc , a polarized stepping relay Rr and a local stepping relay Mr .

When a 50-cycle current impulse is received, it passes over the primary of transformer T . The current induced in the secondary of T is rectified by Rc , and operates Rr over its left-hand winding. Relay Rr in turn energizes Mr ,

which causes the impulse receiving switch SM to take a number of steps, corresponding to the number of A.C. impulses received.

The additional transmission loss introduced by the receiving unit is negligible, the impedance on voice current frequencies being of the order of $35\ 000\ \Omega$. This is due to the action of the rectifier Rc and to the fact that the unit is tuned to 50 cycles by means of condenser C .

It is well known that the resistance of a selenium rectifier is a function of the current. At speech currents of normal level the resistance of the rectifier is very high, so that the secondary of the transformer T is in effect practically open.

The direct current output of the rectifier is, of course, slightly undulated and might cause relay Rr to chatter on its front contact. Relay Rr , therefore, has been provided with a second winding which is connected to battery over a condenser C_1 .

When Rr closes its front contact, condenser C_1 is charged, and the charging current through the right-hand winding develops a magnetic flux, which aids the flux of the left-hand winding, thus rendering the front contact pressure less dependent on variations in the rectifier current. When Rr opens its front contact, C_1 discharges, and a reverse magnetic flux is built up, which assists the de-energization.

The discharge of C_1 not only speeds up the release of Rr , but it also delays the re-operation of Rr , if the interval between two successive impulses should be very short. In this manner, the impulses transmitted to relay Mr are partially corrected.

The ratio of the impulses transmitted by M to the stepping magnet SM can also be varied, if found necessary, by adjusting the parallel resistance R .

With A.C. dialling tie lines, no continuous current flows in the line wires, a condition which is contrary to D.C. tie line operation. Since a 50-cycle current is within the audible range, it would obviously interfere with conversation.

(c) *Supervision*

A 50-cycle tie line is always designed in the form of a self-contained circuit and is arranged for "front" release. The D.C. self-contained tie line, on the other hand, gives "last party" release.

(d) *Method of Operation*

There is no difference between the method of operation of a 50-cycle and a direct current self-contained tie line. The P.A.B.X. subscriber is not aware of the use of A.C. dialling.

(e) *Range of Operation*

A 50-cycle receiving unit, as shown in Fig. 10, will work satisfactorily over approximately 80 km of 1 mm loaded cable (177/63 mH) with a sending voltage of 50 volts.

(f) *Scope*

P.A.B.X. networks with 50-cycle tie lines are gradually finding wider application and, in

many cases, should be able to replace to advantage A.C. intercall systems.

6. TIE LINE INTER-CONNECTION OF A GROUP OF P.A.B.X.'S

Thus far only direct tie lines between two P.A.B.X.'s have been discussed. For the inter-connection of three or more installations, the provision of adequate tie line service raises new problems. Such networks may be realized in two different ways, i.e., as a "mesh" type or as a "star" type network.

6.1 Mesh Type Networks

A typical mesh type network is illustrated in Fig. 11. The automatic P.B.X.'s at A , B , C and D are inter-connected by means of direct tie lines, and A is also connected to a manual switchboard M .

This kind of network does not present any difficulty. The tie lines may be of any of the different types already described.

6.2 Star Type Networks

The prototype of a star type network is shown in Fig. 12, where A , B , C and D represent four P.A.B.X.'s with full automatic service between any two substations without the intervention of an operator.

A star network introduces a principle of

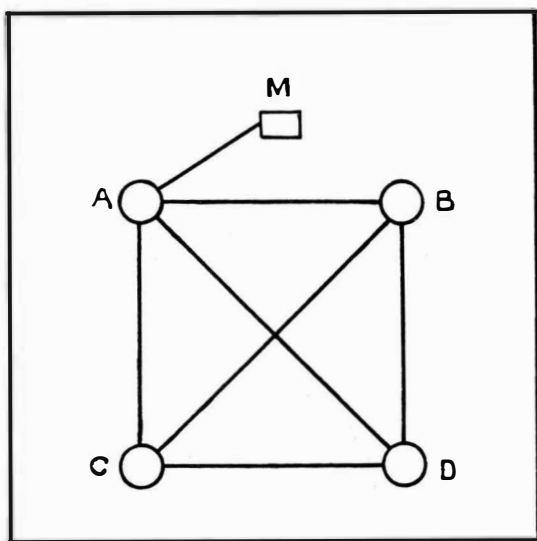

Fig. 11—Mesh Type Network.

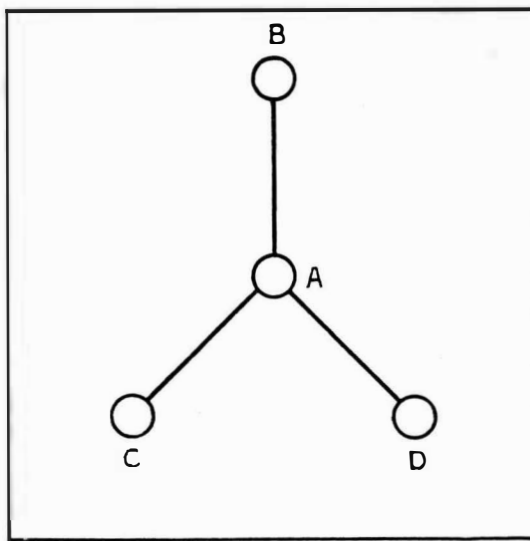

Fig. 12—Star Type Network.

traffic routing, generally referred to as tandem working, which simply means that the traffic between outlying exchanges must pass via a third or intermediate office, called a tandem exchange. Thus in Fig. 12, the P.A.B.X. at *A* serves as a tandem point.

A network of this structure has certain fundamental characteristics which may be summarized under three headings, viz. :

- (a) Method of numbering;
- (b) Method of signalling;
- (c) Method of tandeming.

6.3 Method of Numbering

With interworking telephone systems a distinction is made between "closed" and "open" numbering.

"Closed" numbering includes subscribers' lines in all exchanges in one uniform numbering scheme without distinctive exchange prefixes, and necessarily with only one dialling tone.

An "open" numbering scheme is a prefix system. Local numbers, which may comprise a variable number of digits, are dialled on receiving local dialling tone. On inter-office calls the variable prefix is included in the local number, depending on the exchange to which the wanted number is connected. One or two dialling tones may be employed.

Both schemes may, in principle, be applied in P.A.B.X. networks. A closed numbering scheme, however, implies a rather uniform network structure, which very rarely is encountered in P.A.B.X. application. In the great majority of cases, therefore, a P.A.B.X. network is based on open numbering. For reasons indicated hereinafter, two dialling tones are practically always required.

Although open numbering usually cannot be made strictly uniform, it ought at least to comprise uniform prefixes, that is, a subscriber should have only one number (prefix included) listed in the telephone directory, and he should always be called by this number from any station within the system, except on purely local calls where the exchange prefix is omitted.

This may seem an obvious and elementary requirement, and in rural and national dialling systems it is always fulfilled. In P.A.B.X. design, however, the problem is more complicated, due to the great diversity of the various

equipments which constitute an average P.A.B.X. network. It would frequently be both cheaper and easier to employ different prefixes for the same subscriber, depending on the point of origin of the call. Such operating methods, however, inevitably give rise to confusion.

6.4 Method of Signalling

The signalling and impulsing between P.B.X.'s may be carried out by direct current or by 50-cycle alternating current. The choice between these two systems depends primarily on the physical layout of the outside plant, and has no direct relation to the numbering scheme or method of operation.

6.5 Method of Tandeming

As previously mentioned, P.A.B.X. technique in most cases utilizes two dialling tones for the establishment of a call outside of a subscriber's own switchboard, be it via a tie line or via a junction.

The second dialling tone is not quite indispensable from a technical viewpoint. As a matter of fact it could be omitted, either by giving the stations access to a register, or by applying the principle of forward impulsing.

A register would receive and store the digits of the dialled number, and would control the various selections on well-known Rotary switching principles. A P.A.B.X. station might have access to a register in its own switchboard, or might automatically seize a junction to a parent exchange provided with registers.

By forward impulsing, which is the basis of the step-by-step system technique, a junction or tie line would be picked up in the arc of a selector in the same way as an outlet to a local switching stage. Applied to P.A.B.X. design, this scheme would result in the connection of a tie line as a regular subscriber's line at both ends.

Small and medium sized P.A.B.X.'s are not furnished with registers due to economic considerations. The reasons for abandoning the forward impulse method via regular P.A.B.X. links are enumerated in section 3.

In P.A.B.X. networks, consequently, the most economical and practical alternative is the use of two dialling tones. The universal method

of operation can, therefore, be summarized as follows:

- (1) Remove handset and wait for local dialling tone;
- (2) Dial first digit of prefix;
- (3) Wait for dialling tone from the tandem exchange;
- (4) Dial the remaining digits of the prefix and the wanted number.

After a substation subscriber at an outlying P.A.B.X. has become connected to the tandem exchange, he is again confronted with the problem of obtaining access to a tie line leading to another outlying P.A.B.X. He might wait for a third dialling tone, but this would undoubtedly complicate the method of operation and might create confusion, resulting in unsatisfactory service.

It will be understood, therefore, that although the switching problem of seizing a tie line is exactly the same in an outlying P.A.B.X. as in a tandem exchange, the solution of the problem as explained above for an outlying P.A.B.X. cannot be applied to a tandem exchange, due to the practical necessity of limiting the number of dialling tones to two. The tandem circuits must, consequently, independently of economic considerations, be designed on the basis of either register control or forward impulsing. Both methods are in actual use.

(a) Register Control

This solution is the most flexible, but also the most expensive, at least for small installations. The tie lines terminate as regular subscribers' lines at the tandem point and as self-contained tie lines at the outgoing P.A.B.X.

The tandem equipment may consist of a standard P.A.B.X., arranged for combined local and tandem working (as, for example, the 7-D P.A.B.X.) or may comprise separate tandem links and registers, specially designed for tie line inter-connection.

(b) Forward Impulsing

This scheme results in inexpensive and simple equipments, but its application is limited to certain types of networks. The tie lines are self-contained at both ends.

A typical 50-cycle A.C. network using forward

impulsing has previously been described.¹ It can be applied to small and medium sized P.A.B.X.'s where the digit receiving switch is of the rotary step-by-step type, and where the number of tie lines per direction is not too great.

7. SPECIAL TIE LINES

Requests are sometimes received for the provision of special operating facilities on tie lines, such as call-back and transfer, or extension of city connections. While it would be partly beyond the scope of the present article to analyze the design aspects of the various solutions realized (due to unavoidable reference to junction design and operating methods), a brief outline of the switching problems follows:

7.1 Call-back and Transfer

Call-back and transfer to stations belonging to the same P.A.B.X. can be introduced without difficulty in self-contained tie lines. The arrangement adopted is very similar to the standard junction scheme, and comprises a differential relay at each end, operated from a button on the subset.

This feature is seldom employed in connection with inter-P.A.B.X. traffic only, but it may be useful if city or toll connections are extended over tie lines.

7.2 Extension of City Connections

It frequently happens that a subsidiary plant or branch office, connected by tie lines to a main office, has no access to a public telephone exchange, due to its isolated location. In such cases, it may be found desirable to enable the main office P.A.B.X. attendant to extend city and toll connections via the tie lines to a substation in the branch office P.A.X. The manner of providing this facility depends primarily on the type of attendant's equipment installed at the main office.

A cord type attendant's board presents many advantages with respect to the handling of different groups of junctions without undue complication of the automatic circuits, whereas a cordless attendant's set entails rather important changes in the design of the tie lines.

(a) Cord Type Board

With a cord type attendant's board, it is com-

¹ "Airport P.A.B.X. Network," by R. T. Ringkjøb, *Electrical Communication*, January, 1939.

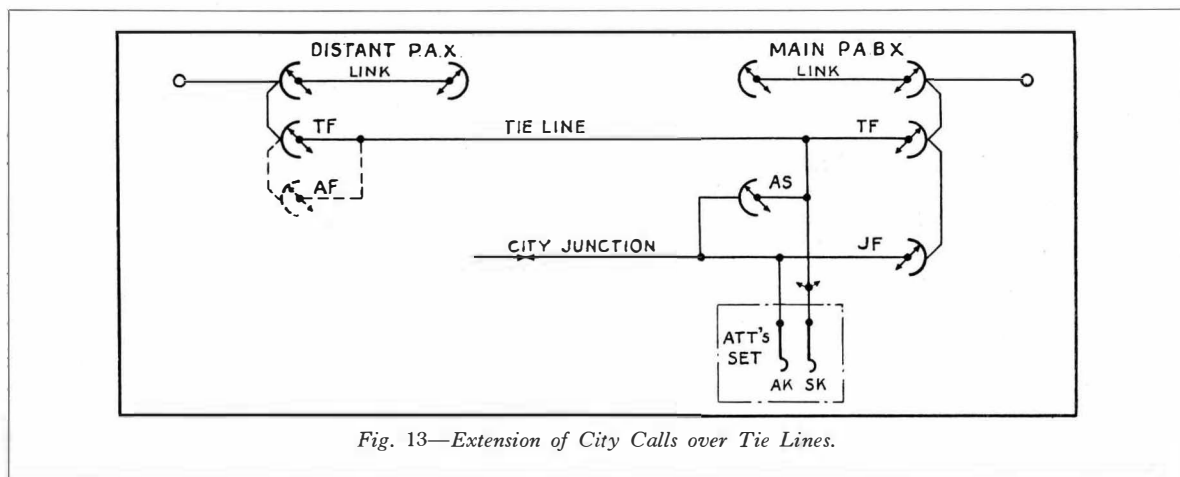

Fig. 13—Extension of City Calls over Tie Lines.

paratively easy to provide manual "in" and "out" city service via tie lines. For such service, self-contained circuits, comprising a jack and two lamps (busy and calling lamps) on the attendant's board, would be required.

To extend an incoming city call the attendant plugs into the jack of a free tie line and dials the number of the wanted distant party. When, after conversation, the latter hangs up, a clearing signal must be transmitted to the attendant, since usually no such signal is received from the city exchange.

On an outgoing city call, the distant party dials a single digit to pick up the tie line, and a second single digit to light the calling lamp in front of the attendant, who extends the call to the wanted city subscriber manually.

(b) Cordless Attendant's Set

In P.A.B.X. systems using cordless attendant's sets, the problem of connecting a tie line to a city junction, or *vice versa*, can be solved in several ways. The primary aim of the designer naturally is to achieve a simple method of operation for both the attendant and the distant P.A.X. subscribers. Usually, automatic "out" and manual "in" city service is provided.

The most frequently adopted solution consists in the addition of a switch per tie line at the main P.A.B.X. end. All junction circuits are connected to the arc of the additional switch, which has two functions:

- (1) On an automatic outgoing city call it hunts for a free junction;
- (2) On an incoming city call it hunts for the

particular junction on which the attendant is waiting. Fig. 13 shows the junction diagram of such an arrangement.

A distant P.A.X. party desiring an automatic outgoing city connection dials a single digit, different from the digit assigned to regular tie line calls at the main P.A.B.X. The additional switch *AS*, consequently, hunts for and picks up a free junction. When city dialling tone is received, the full wanted number is dialled.

On an incoming city call destined for a distant P.A.X. party, the attendant depresses a starting key, *SK*, common to all tie lines in a given direction. The additional switch of all free tie lines then hunts for the junction on which the attendant is waiting. After a tie line has become attached, a visual signal is given to the attendant, who releases the starting key and dials the wanted distant party's number.

With the automatic outgoing city service as described above, all distant P.A.X. stations have access to the city network. It is possible, however, to restrict certain stations from such service by adding an extra finder *AF* to the tie line at the distant end. The regular tie line finder, *TF*, would then be picked up by any station dialling, say, "8," for inter-P.A.B.X. calls, whilst the additional finder would be picked up by unrestricted stations dialling, say, "0," for outgoing city calls.

Local call-back and transfer features may be introduced on this kind of tie line. As an alternative, the distant P.A.X. station may be given the facility of recalling the main P.A.B.X. attendant on an established city connection.

Experimental Researches on the Propagation of Electro-Magnetic Waves in Dielectric (Cylindrical) Guides*

By A. G. CLAVIER and V. ALTOVSKY,

Laboratoires L.M.T., Paris, France

ELECTRO-MAGNETIC waves, in the first instance, were utilized through radiation into space; this represented the first "radio-electric transmissions." It is known, moreover, that under certain conditions the surface of the earth and the ionized layers of the higher atmosphere produce reflections of a serviceable nature and that the waves are in some way directed round the globe, thereby improving the transmission efficiency to a considerable degree. The efficiency may be further reinforced by concentrating the radiation directionally; "directed waves" are then obtained.

For a still better reception of the transmitted energy, however, electromagnetic waves may be propagated through closed channels or "guides," their utilization in the final analysis being obviously dependent on economic considerations. In addition to a reduced waste of energy, such guided transmissions, as compared with the non-guided type, afford advantages of great secrecy, decreased interference and improved quality, as well as more stable and reliable transmission characteristics.

The aim has been to apply increasingly higher frequencies to cables in order to utilize them for transmitting a correspondingly greater range of frequencies so as to provide a large number of simultaneous communication channels. Furthermore, in certain outstanding cases, such as high quality musical transmissions and especially television, extensive frequency bandwidths are necessary for attaining high quality transmission.

As the frequency increases, ordinary cables become less and less suitable for such applications due to prohibitively high attenuation. Accordingly, special structures consisting of two concentric conductors separated by high-

grade insulators have been developed: the coaxial cable.

Closer study of the theoretical conditions governing the propagation of electro-magnetic waves has shown that the presence of an interior conductor is not indispensable. The "wave guide" thus may take the form of a simple hollow metallic tube.

In the present article brief reference is made to the essential bases of the theory of guided waves, the complete mathematical development of which has been the object of earlier studies†. Attention is devoted mainly to experimental aspects of the problem; and, in particular, a detailed description is given of equipment used in demonstrating the fundamental characteristics of centimetre electro-magnetic wave propagation in dielectric guides.

I.—RÉSUMÉ OF THE THEORETICAL CONSIDERATIONS RELATING TO DIELECTRIC GUIDES

When making a theoretical study of the propagation of electro-magnetic waves in a dielectric medium of cylindrical symmetry defined by a metallic sheath, it is desirable to assume as a first approximation that the medium is a perfect dielectric (zero conductivity) and that the sheath is a perfect conductor (infinite conductivity). An electro-magnetic wave is characterized at each point of the transmission path by an electric vector field \vec{E} and a magnetic vector field \vec{H} related as indicated by Maxwell's equations:

$$\begin{aligned} \epsilon \frac{\partial \vec{E}}{\partial t} &= \text{curl } \vec{H} \\ -\mu \frac{\partial \vec{H}}{\partial t} &= \text{curl } \vec{E} \end{aligned} \dots\dots\dots (1)$$

ϵ is the dielectric coefficient and μ the per-

* Republished in slightly modified form from "Revue Générale de l'Electricité," May 27 and June 3, 1939.

† See Bibliography at end of article.

meability coefficient of the medium under consideration.

These equations should be applied with respect to their limiting conditions derived from the fundamental electro-magnetic laws which, if any vector quantities are present on the metallic wall, require that the electric vector be normal and the magnetic vector tangential.

Energy considerations suggest the resolution of the vectors \vec{E} and \vec{H} into cross-sectional components \vec{E}_s, \vec{H}_s , and axial components \vec{E}_z, \vec{H}_z .

Assuming an elementary volume comprised between two cross-sections S_1 and S_2 and the metallic wall, no flux passes through the metallic sheath. The sum of the flux through S_1, S_2 has a mean value of zero per cycle; the mean flow of energy W_m through a straight section is, therefore, constant. This flow is expressed as a function of the only components, \vec{E}_s, \vec{H}_s in the cross-section:

$$W_m = \int_s \frac{1}{4\pi} [\vec{E}_s \times \vec{H}_s] ds \dots\dots\dots(2)$$

It will thus be seen that the components \vec{E}_s and \vec{H}_s must coexist in order to ensure propagation in the axial direction. Investigation of possible types of progressive waves then points to the application of a group of linear differential equations in which the cross-sectional components are expressed as a function of the axial components.

The general solution results from the superposition of the following three particular cases:

- (1) The axial components \vec{H}_z and \vec{E}_z are both zero in the volume under consideration;
- (2) The axial magnetic field component \vec{H}_z is zero throughout;
- (3) The axial electric field component \vec{E}_z is zero throughout.

(1) \vec{E}_z and \vec{H}_z Zero Throughout—Coaxial Wave (Fig. 1)

Analysis shows that in this case the electric field \vec{E} is governed by a two-dimensional

potential $U(\rho, \theta)$ which checks with Laplace's equation $\Delta U = 0$.

The electric field is normal at the sheath surface, of which the cross-section represents an equipotential line. Moreover, the potential U verifying Laplace's equation must be constant within the equipotential line unless internal charges are present. The field \vec{E} , therefore, is everywhere equal to zero inside of the metallic sheath; hence no possible propagation occurs in a dielectric guide when \vec{E}_z and \vec{H}_z are zero throughout.

Conditions obviously are modified if a conducting surface be introduced into the first cylindrical sheath. A well-known form is the coaxial cable, the potential U then taking the form:

$$U = -A \log \rho + B; \dots\dots\dots(3)$$

A and B are constants.

The fundamental characteristics of this kind of propagation may easily be deduced from the above equations.

The vectors \vec{E} and \vec{H} then reduce to the components E_ρ, H_θ ; they are perpendicular to each other and in phase.

The wave is propagated with a velocity

$$v = \frac{1}{\sqrt{\epsilon\mu}}, \text{ equal to the velocity of light in a}$$

homogeneous dielectric medium of constants ϵ, μ .

These fields may be expressed by:

$$E_\rho = \sqrt{\frac{\mu}{\epsilon}} H_\theta = \frac{A}{\rho} e^{j(\omega t - \gamma z)}, \dots\dots\dots(4)$$

ω being the angular frequency ($2\pi f$); $\gamma = \frac{2\pi}{\lambda'}$

$= \frac{2\pi f}{v'}$, where λ' and v' , respectively, are the

wavelength and the phase velocity in the cable.

It is therefore possible to pass from equations of vector fields to those of differences of potential V between conductors and of currents I at their surface. If a and b be the diameters of the two metallic sheaths ($a < b$):

$$V = 2\sqrt{\frac{\mu}{\epsilon}} \log \frac{b}{a} e^{j(\omega t - \gamma z)} \dots\dots\dots(5)$$

$$\frac{V}{I} = 2\sqrt{\frac{\mu}{\epsilon}} \log \frac{b}{a} = Z \dots\dots\dots(6)$$

Z is the characteristic impedance of the coaxial cable.

Consideration of the constituent vector fields thus leads to the same derivation of the propagation characteristics as by the application of well-known Kirchhoff's equations.

Let us revert to the guide constituted by a simple metallic sheath limiting a dielectric medium, and examine the case where one of the vectors, either electric or magnetic, has an axial component.

(2) Electric Vector with Single Component E_z along the Axis-E Wave (Fig. 1)

The condition $H_z = 0$ gives the equations :

$$E_\rho = \sqrt{\frac{\mu}{\epsilon}} \frac{v}{v'} H_\theta \dots\dots\dots(7) \quad \text{taking}$$

$$E_\theta = -\sqrt{\frac{\mu}{\epsilon}} \frac{v}{v'} H_\rho \dots\dots\dots(8)$$

section E_s (E_ρ, E_θ) and H_s (H_ρ, H_θ) are perpendicular to one another and in phase. As above, v is the velocity of light in an undefined homogeneous medium with coefficients ϵ and μ ; v' is the axial phase velocity in the interior of the guide.

The transverse components may be expressed as functions derived from E_z :

$$j k^2 E_\rho = \gamma \frac{\partial E_z}{\partial \rho}$$

$$j k^2 E_\theta = \frac{\gamma}{\rho} \frac{\partial E_z}{\partial \theta} \dots\dots\dots(9)$$

$$-j k^2 H_\rho = \frac{\omega \epsilon}{\rho} \frac{\partial E_z}{\partial \theta},$$

$$-j k^2 H_\theta = -\omega \epsilon \frac{\partial E_z}{\partial \rho},$$

$$k = \sqrt{\omega^2 \epsilon \mu - \gamma^2} = 2\pi f \sqrt{\frac{1}{v^2} - \frac{1}{v'^2}} \dots\dots(10)$$

indicating that the components of the cross

At a given point, in particular, the component

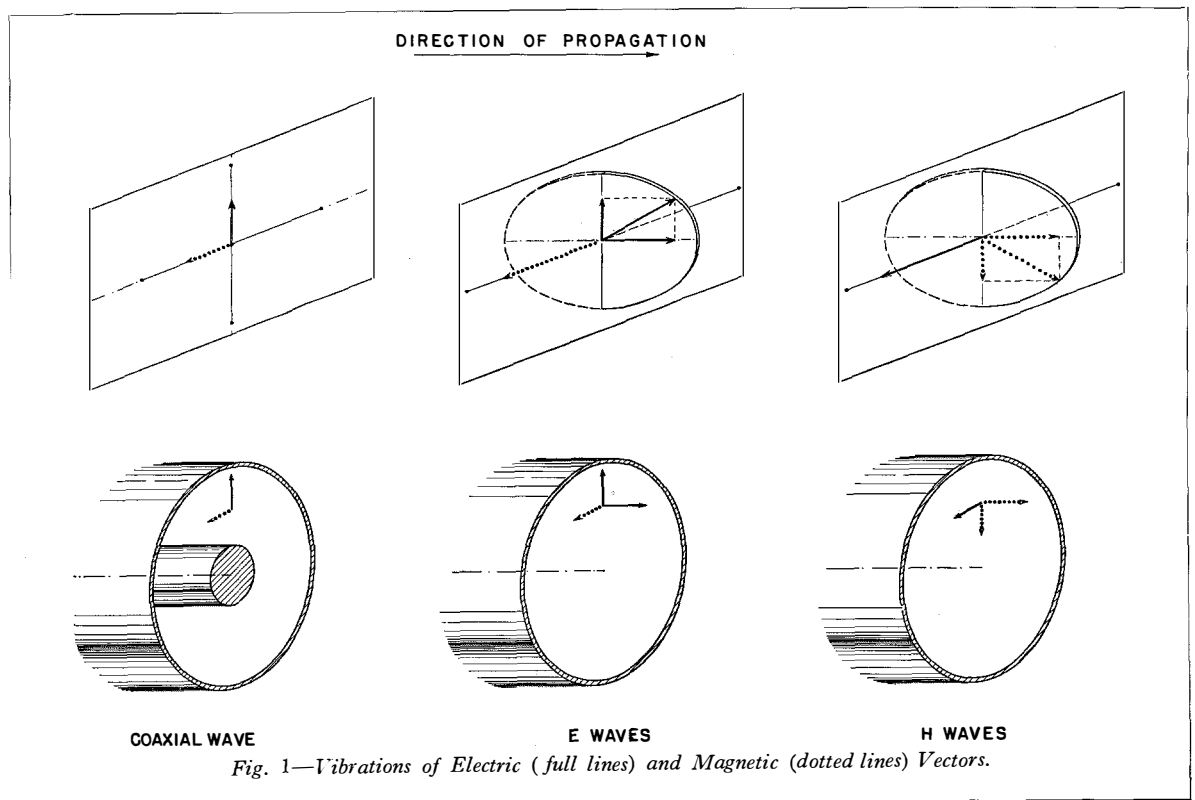

E_z along the axis is out of phase by $\frac{\pi}{2}$ with respect to the cross-sectional components.

The oscillation of the vectors at a point is represented in Fig. 1 (E waves): the magnetic vector (dotted line) has a rectilinear vibration in the plane of the cross-section; the electric vector (full line) has an elliptic vibration in a plane parallel to the axis. An investigation of the distribution of the amplitudes E_z of the axial component at different points of the cross-section yields the classical Bessel equation of which the integral takes the general form:

$$E_z = A_n J_n(k\rho) + B_n Y_n(k\rho);$$

J_n and Y_n are Bessel functions of the first and second type and of the n th order. The function Y is infinite for $\rho = 0$; it does not meet the case under consideration.

The equations for the E waves may finally be written:

$$\begin{aligned} E_z &= A_n J_n(k\rho) \cdot \cos n\theta \cdot e^{j(\omega t - \gamma z)} \\ E_\rho &= \frac{2\pi}{\lambda'} \frac{1}{k} A_n J'_n(k\rho) \cdot \cos n\theta \cdot e^{j(\omega t - \gamma z - \frac{\pi}{2})} \\ E_\theta &= -\frac{2\pi}{\lambda'} \frac{n}{k^2 \rho} A_n J_n(k\rho) \cdot \sin n\theta \cdot e^{j(\omega t - \gamma z - \frac{\pi}{2})} \\ &\dots\dots\dots(11) \\ H_\rho &= \frac{2\pi}{\lambda} \sqrt{\frac{\varepsilon}{\mu}} \frac{n}{k^2 \rho} A_n J_n(k\rho) \cdot \sin n\theta \cdot e^{j(\omega t - \gamma z - \frac{\pi}{2})} \\ H_\theta &= \frac{2\pi}{\lambda} \sqrt{\frac{\varepsilon}{\mu}} \frac{1}{k} A_n J'_n(k\rho) \cdot \cos n\theta \cdot e^{j(\omega t - \gamma z - \frac{\pi}{2})} \end{aligned}$$

Thus it is possible for E waves to exist in a guide provided that the limiting conditions at the contiguous surface of the dielectric and the metallic envelope are satisfied. In a guide of radius b , it is necessary that:

$$J_n(kb) = 0 \dots\dots\dots(12)$$

which gives the possible values of k .

Briefly, a particular E wave is characterized, on the one hand, by its distribution law along a circumference centred on the axis (value of n); and, on the other hand, by its distribution law along a radius of the cross section (order of the root of equation (12)).

The fundamental wave in this class of propagation, designated E_0 , is that for which $n = 0$. It gives uniform distribution along a circumference centred on the axis, the first root other than zero of Bessel's function J , of order 0, being taken:

$$J_0(k\rho) = 0.$$

Fig. 2 represents the distribution of the vectors at a given moment for a progressive wave E_0 .

(3) The Magnetic Vector only has a Component H_z along the Axis— H Waves (Fig. 1)

The condition $E_z = 0$ gives the following equations:

$$\begin{aligned} E_\rho &= \sqrt{\frac{\mu}{\varepsilon}} \frac{v'}{v} H_\theta \\ &\dots\dots\dots(13) \\ E_\theta &= -\sqrt{\frac{\mu}{\varepsilon}} \frac{v'}{v} H_\rho \end{aligned}$$

The cross-sectional components, in this case also, are perpendicular to one another and in phase.

These components may again be expressed as a function derived from the axial component H_z and it will be seen that they are dephased by $\frac{\pi}{2}$ with respect to H_z .

The vibration of the vectors at a point is indicated in Fig. 1 (H waves). The electric vector (continuous line) oscillates rectilinearly in the plane of the cross-section. The magnetic vector (dotted line) has an elliptic vibration in a plane parallel to the axis.

The equations for H waves may be developed the same as for E waves; they are:

$$\begin{aligned} H_z &= B_n J_n(k\rho) \cdot \cos n\theta \cdot e^{j(\omega t - \gamma z)} \\ H_\rho &= \frac{2\pi}{\lambda'} \frac{1}{k} B_n J'_n(k\rho) \cdot \cos n\theta \cdot e^{j(\omega t - \gamma z - \frac{\pi}{2})} \\ H_\theta &= -\frac{2\pi}{\lambda'} \frac{n}{k^2 \rho} B_n J_n(k\rho) \cdot \sin n\theta \cdot e^{j(\omega t - \gamma z - \frac{\pi}{2})} \\ &\dots\dots\dots(14) \\ E_\rho &= -\frac{2\pi}{\lambda} \sqrt{\frac{\mu}{\varepsilon}} \frac{n}{k^2 \rho} B_n J_n(k\rho) \cdot \sin n\theta \cdot e^{j(\omega t - \gamma z - \frac{\pi}{2})} \\ E_\theta &= -\frac{2\pi}{\lambda} \sqrt{\frac{\mu}{\varepsilon}} \frac{1}{k} B_n J'_n(k\rho) \cdot \cos n\theta \cdot e^{j(\omega t - \gamma z - \frac{\pi}{2})} \end{aligned}$$

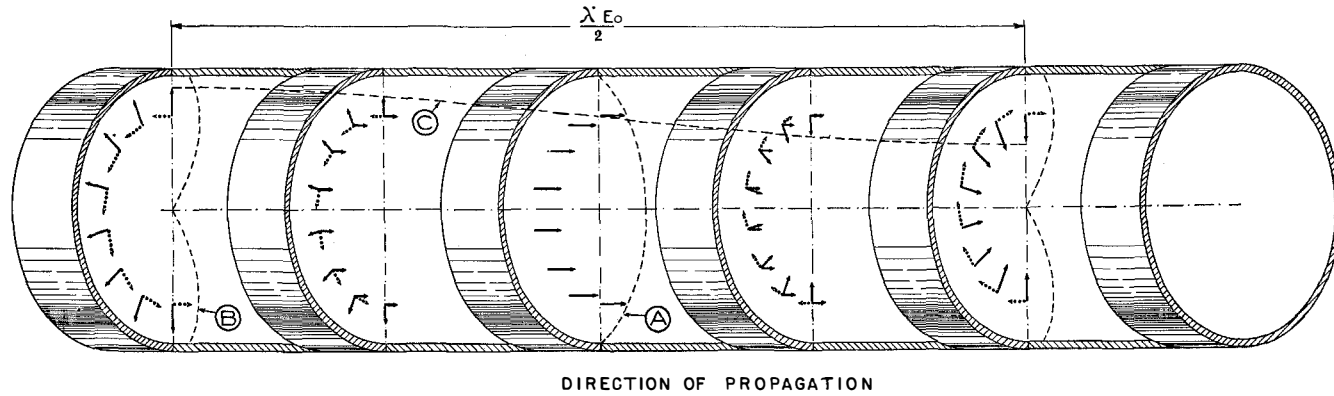

Fig. 2—Progressive E_0 Wave : Electric (full lines) and Magnetic (dotted lines) Vectors. Curve A : distribution of longitudinal vectors along the radius (Bessel function $J_0(K\rho)$). Curve B : distribution of transverse vectors along the radius (Bessel function $J_1(K\rho)$). Curve C : distribution of all vectors along the axis (sinusoidal function).

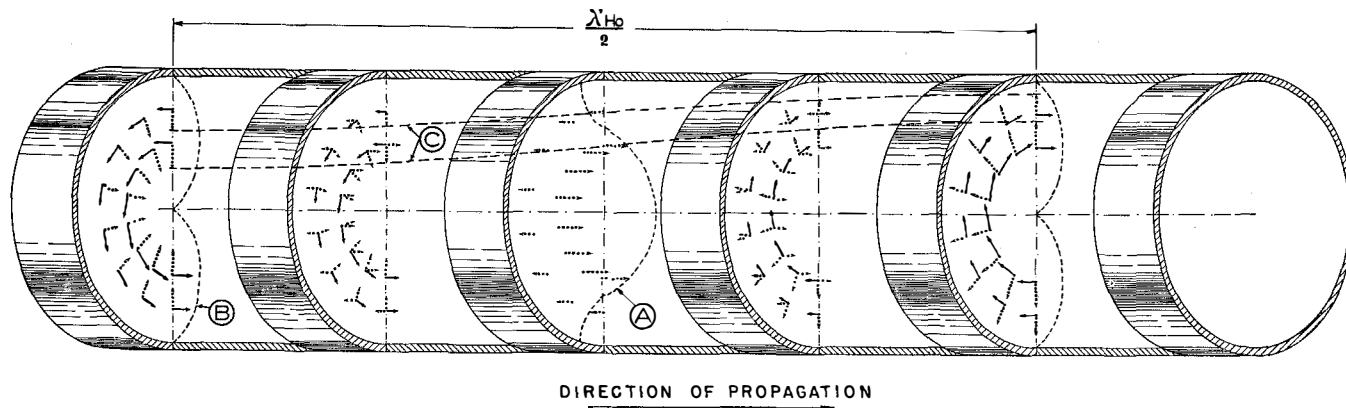

Fig. 3—Progressive H_0 Wave : Electric (full lines) and Magnetic (dotted lines) Vectors. Curve A : distribution of longitudinal vectors along the radius (Bessel function $J_0(K\rho)$). Curve B : distribution of transverse vectors along the radius (Bessel function $J_1(K\rho)$). Curve C : distribution of all vectors along the axis (sinusoidal function).

Thus H waves may exist in a guide provided that the following condition be satisfied :

$$J'_n(kb) = 0 ; \dots\dots\dots(15)$$

J'_n is the derivative of J_n .

Similarly to E waves, a particular H wave is characterized by the value of n and the order of the root of equation (15).

The value of n governs the distribution law of the amplitude of the vectors along the circumference centred on the axis. The order of the root of the Bessel function governs the law of distribution along the radius. This distribution is illustrated by Fig. 3 which represents a progressive H_0 wave at a given instant. The fundamental H_0 wave corresponds to $n=0$ (uniform circular distribution) and the first non-zero root of :

$$J'_0(k\rho) = -J_1(k\rho) = 0. \dots\dots(16)$$

LOWER FREQUENCY LIMITS OF E AND H WAVES

For the type of wave applicable to the coaxial cable no E_z , E_θ or H_ρ vectors exist.

The limiting conditions at the surface of separation of the dielectric and metallic walls are already fulfilled and the problem of a theoretical frequency limit does not arise. For E and H waves in a guide, conditions are different, and it is necessary that equations (12) and (15), respectively, be satisfied.

Taking the first non-zero root of these equations, r_n , (r'_n for (15)), the following results :

$$kb = r_n \text{ (or } r'_n \text{),}$$

assuming

$$2\pi f \sqrt{\frac{1}{v^2} - \frac{1}{v'^2}} = \frac{r_n}{b} \dots\dots\dots(17)$$

This relationship shows that the phase velocity v' in the guide must always be greater than the velocity v of light in the dielectric medium considered.

The smallest value of f , say f_c , which permits of propagation in a given cable, corresponds to an infinite value for v' ; consequently,

$$f_c = \frac{kv}{2\pi} = v \frac{r_n}{2\pi b} \dots\dots\dots(18)$$

This cut-off frequency, f_c , corresponds in

the unlimited medium ϵ , μ , to a cut-off wavelength of :

$$\lambda_c = \frac{2\pi b}{r_n} \dots\dots\dots(19)$$

The table below gives the value of the first roots r_n , r'_n , of the J_n and J'_n functions.

n	0	1	2
r_n	2.40	3.83	5.1
r'_n	3.83	1.84	3

The following observations apply :

- (1) The H_1 wave makes it possible to use the lowest frequency for a guide of given diameter ;
- (2) H_0 and E_1 waves have the same cut-off frequency due to the equation $J'_0 = -J_1$.
- (3) From the viewpoint of most immediate application, the waves to be considered are the fundamental E_0 and H_0 waves, also the H_1 , which gives the most favourable cut-off frequency.
- (4) The cut-off frequency corresponds to a wavelength in the free dielectric medium of the same order of magnitude as the diameter of the guide in the most favourable case.

In order to utilize cables in the form of guides of practical dimensions, it is consequently necessary to resort to oscillations of extremely high frequency, corresponding to wavelengths of only a few centimetres.

A dielectric medium with a dielectric constant higher than air would make it possible, other factors being equal, to employ a lower frequency, inversely proportional to the square root of the dielectric coefficient. The dominant consideration, nevertheless, is the energy loss in transmission along the cable, since it governs the maximum length of cable between repeater stations of given gain. This question will be discussed later.

PHASE AND GROUP VELOCITIES

In the case of a coaxial cable without energy loss, the wave propagation velocity would be $v = \frac{1}{\sqrt{\epsilon\mu}}$ independent of frequency. Phase and

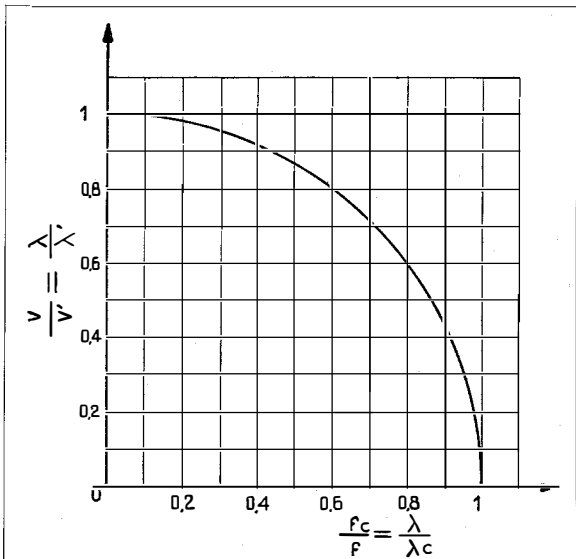

Fig. 4—Law of Variation of Phase Velocity in a Guide.

group velocities would be equal to the velocity of light in a homogeneous medium $\epsilon\mu$.

In the case of E and H waves, on the contrary, phase velocity v' , as previously indicated, is greater than the velocity of light in a free medium. Reverting to equations (17) and (18) it follows that :

$$2\pi f \sqrt{\frac{1}{v^2} - \frac{1}{v'^2}} = \frac{2\pi f c}{v}; \dots\dots(20)$$

hence,

$$\left(\frac{f_c}{f}\right)^2 + \left(\frac{v}{v'}\right)^2 = 1.$$

This relationship is represented by the circular curve of Fig. 4. It permits the determination of the phase velocity v' as a function of the applied frequency f , the cut-off frequency f_c being known. The latter depends on the type of wave, the radius of the guide, and the velocity v in a free medium corresponding to the dielectric considered.

As the operating frequency approaches the cut-off frequency, the phase

velocity increases indefinitely. With increased frequency, the phase velocity decreases and, at its limit, approaches the velocity of light in a free medium.

The magnitude which is of interest in the propagation of a modulated signal is the group velocity v_g . In a cable of given diameter, the following obtains :

$$v_g = \frac{\partial \omega}{\partial \gamma} = \frac{v^2}{v'} \dots\dots\dots(21)$$

Since the phase velocity v' is always greater than v , the group velocity v_g is always less than v , the velocity of light in an unlimited medium characterized by the constants ϵ, μ .

II.—EXPERIMENTAL STUDIES OF G.C. SOUTHWORTH AND OF W.L. BARROW

Retracing the bases of the theory sketched in the foregoing to Lord Rayleigh's work in 1897, it is evident that considerable progress was required in the art of generating electromagnetic waves before experimental investigations could be successfully undertaken.

Experimental studies with a view to verifying the characteristics of this new method of transmission were first begun in America, and results were published during the year 1936. The first two investigations related to dielectric guides of circular section, which seemed to be of the most

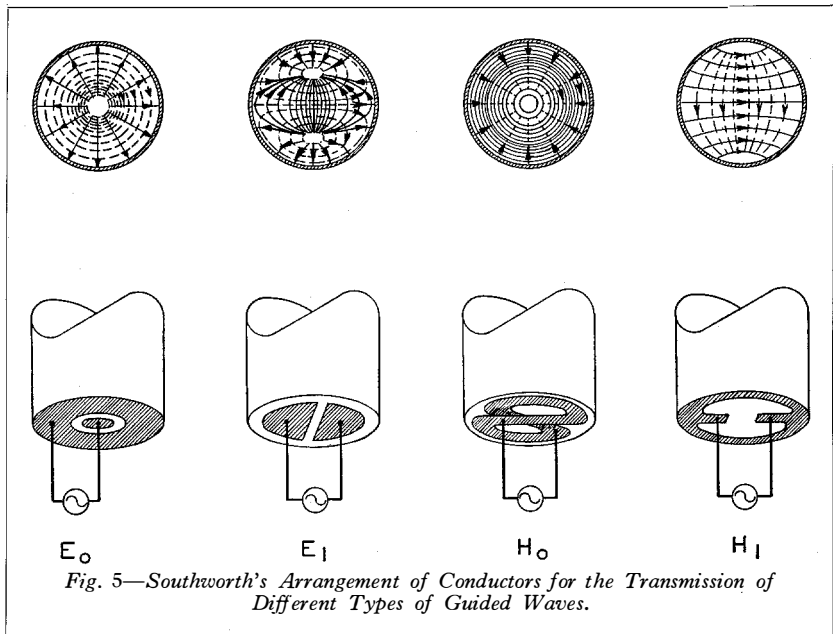
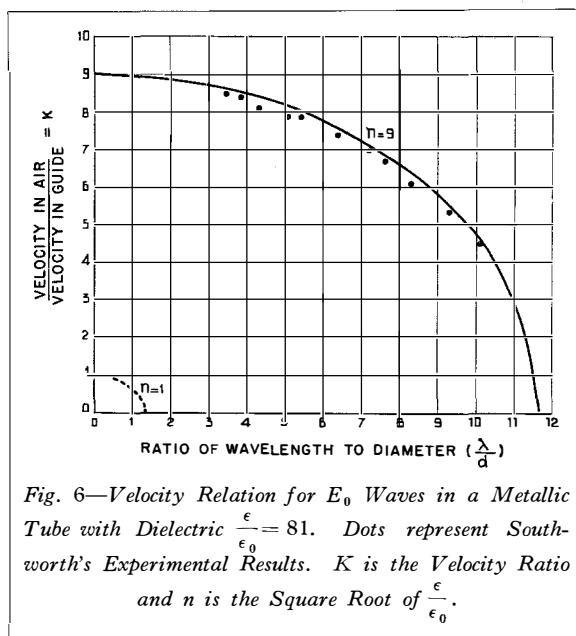

Fig. 5—Southworth's Arrangement of Conductors for the Transmission of Different Types of Guided Waves.



immediate interest from the viewpoint of application.

Southworth started with water as a dielectric and was thus enabled to use metric waves (3 m to 0.75 m, i.e., 100 to 400 Mc/s) and guides 15 to 25 cm in diameter. A column of water 1.20 m in height was contained in a bakelite or copper tube. E waves (E_0 and E_1), and H waves (H_0 and H_1) were investigated, excited as indicated in Fig. 5. By probing the cross-section, field distributions and relative intensities were observed to vary in substantial agreement with calculations. Certain irregularities, apparently, were attributable to the simultaneous presence of different types of waves, it being difficult to obtain a specific type of wave, particularly E_0 and H_0 waves. Another method of exploring the fields showed the reflector effect of screens formed of conductor wires: wires parallel to one diameter for H_1 waves; radial wires for E_0 , and circular wires for H_0 waves. Such screens were found useful in particularizing the excitation.

The phase velocity along the guide was determined accurately by measuring the distances between nodes and anti-nodes under stationary vibration conditions. Fig. 6 indicates the points measured and the curve calculated for the E_0 wave. Similarly, the cut-off frequency was experimentally determined.

Due to considerable dissipation by the water, the investigation was pursued with copper tubes filled with air. These tubes were 10 cm and 15 cm in diameter, and the tests were made with 20 cm (1 500 Mc/s) and 15 cm (2 000 Mc/s) waves, principally of type H_1 . Results relating to phase velocity are illustrated in Fig. 7. Agreement between experiment and calculation is quite remarkable, the differences—less than 1%—being of the order of magnitude of errors in measurement.

To obtain progressive waves the guide must be correctly terminated; the conditions of adaptation are quite critical. The arrangement adopted utilized a thin resistive film placed in a straight section in front of an adjustable reflector piston or a resonance chamber containing a dissipative element. The resonance chamber consisted of a short guide section with resonance and anti-resonance characteristics.

Barrow, independently of Southworth, experimented with a galvanized iron guide 44 cm in diameter and 4.60 m long, the wavelength being about 40 cm. The cut-off characteristic was verified at 25 watts output on a 1 m wavelength. The methods of initiating the waves are indicated in Fig. 8. They correspond to the waves which, following Southworth, may be termed E_0 and H_1 . By means of a probe detector the length of a stationary wave was measured and the field distribution investigated; the results were found to agree closely with theory. Placed at the open end of the guide, the detector may be used to indicate the radiation diagram at the mouth of the guide.

In another series of experiments, Barrow checked the distribution of fields and the value

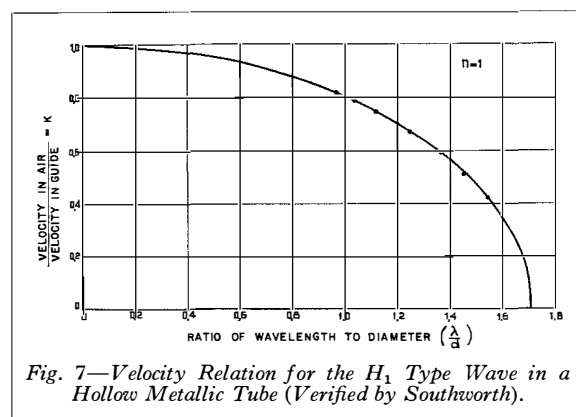

of phase velocity in guides of rectangular section (15 cm × 50 cm) with wavelengths between 40 cm and 1 m. In particular, he traced the end radiation diagrams.

These remarkable experiments aroused considerable interest in scientific and engineering circles, and initiated a series of researches auguring interesting possibilities of application.

III.—L.M.T. LABORATORIES EXPERIMENTAL WORK

Investigations on the propagation of centimetric waves inside conductor tubes were under-taken in 1938 in the L.M.T. Laboratories. Dating from 1929, they had been interested in the properties of electro-magnetic

decimetric and centimetric waves. On March 31st, 1931, the first practical demonstration of Micro-ray Radio was given across the English Channel on a wavelength of approximately 17 cm. The technique thus acquired by experience was found particularly interesting in its application to dielectric guides.

The application of dielectric guide methods of transmission necessitates, in order that it may be economically justified, that the diameter of the guide should not exceed 1 to 2 cm; hence, centimetre or even millimetre wavelengths must be used. Such waves can be produced by positive grid and reflecting electrode tubes derived from the type developed for the Lympne-St. Inglevert Micro-ray link operating on 17.4 cm. Tubes of this type have been developed for operation on wavelengths down to 5 cm. Below 5 cm, magnetron tubes of the non-split anode type are utilized. The shortest wavelength attainable at present in the Laboratories is 12 mm, corresponding to a frequency of 25 000 million cycles per second.

Researches involved principally three types

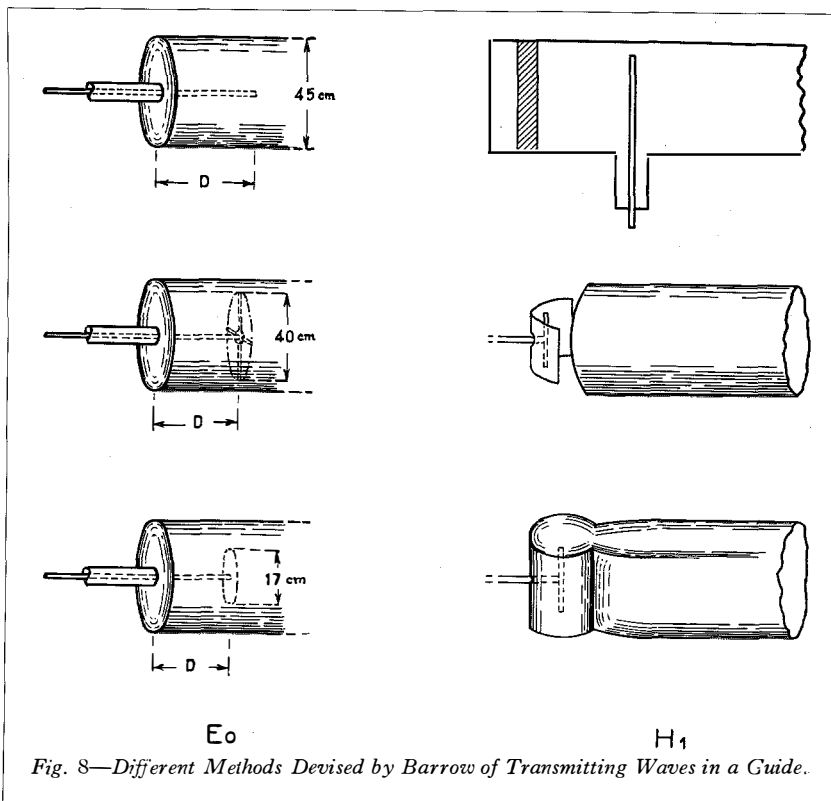

Fig. 8—Different Methods Devised by Barrow of Transmitting Waves in a Guide.

of waves, E_0 , H_0 , H_1 ; the first two types, circular in shape, may be termed the fundamental waves for a circular sectional guide; the third, H_1 , is the most favourable from the viewpoint of cut-off frequency for a specified diameter of guide. Use was made successively of copper tubes some metres in length with diameters of 125, 60, 40, 23, and 16 mm. Wavelengths between 150 mm and 25 mm were utilized, corresponding to frequencies from 2 000 to 12 000 Mc/s.

An experimental demonstration of the most characteristic features of guided waves was given in Paris, in 1938, before the Société des Radio-Électriciens (November 16th), the Société de Physique (November 18th), the Société Française des Électriciens (November 26th—Discussion Week), and the Congrès International in commemoration of the discovery of Hertzian waves at the Palais de la Découverte (November 29th).

Figs. 9, 10, 11 give some idea of the set-up of the apparatus employed in demonstrations. The copper tube (125 mm in diameter) represents the first guide used. The transmitter

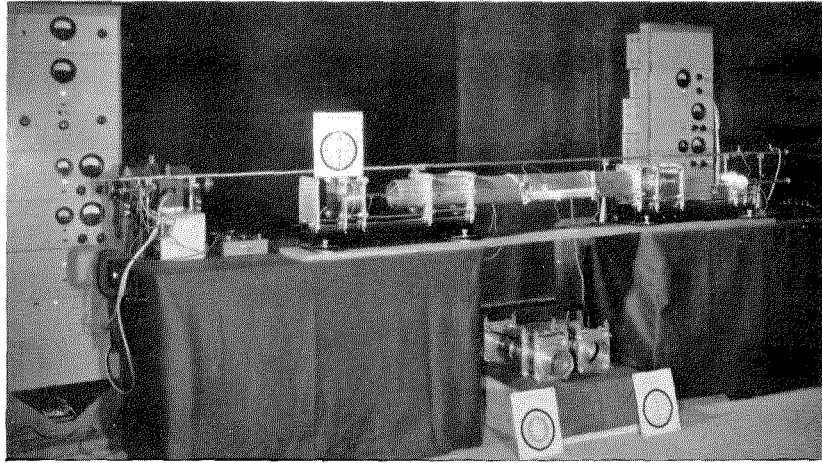

Fig. 9—View of Demonstration Apparatus for the Propagation of Centimetre Waves in Metal Tubes (12.5 cm and 1.6 cm in diameter).

valve, which produces a wavelength of 8 cm, is visible in the centre of Fig. 10 with its power rack in the background. Between the valve and the input of the guide are interchangeable coupling elements suitable for the various types of waves. Two of these coupling elements may be seen in the lower part of Fig. 9. A third one is mounted at the head of the guide. At the opposite end of the guide is a movable truck housing the detector system.

The second guide, placed behind the first, might more appropriately be termed a "cable." It is, in effect, a copper tube 16 mm in diameter. The transmitter supplying the input operates

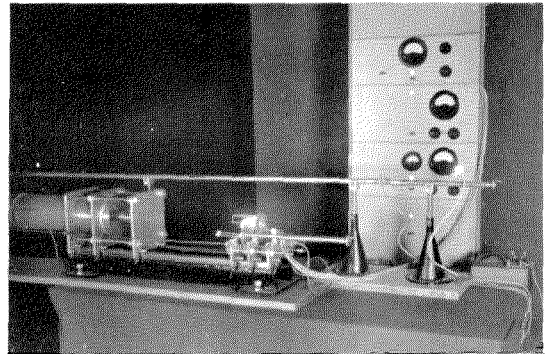

Fig. 10—Positive Grid Generator (wavelength 8 cm), in centre; Coupling Apparatus to the 12.5 cm Guide (E_0 Wave), at left; Receiving Apparatus of a 1.6 cm Guide, at right.

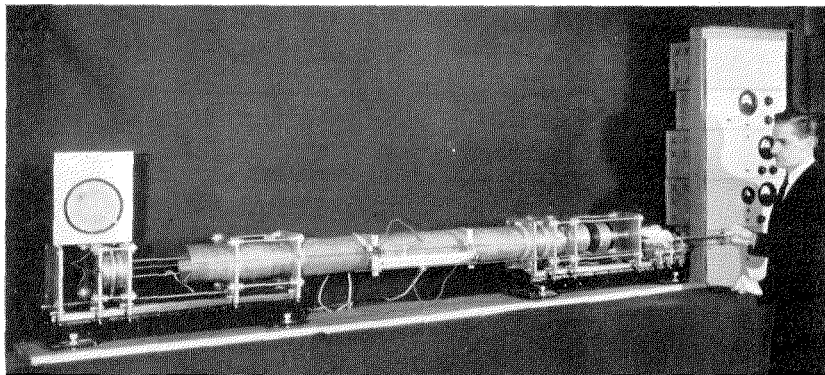

Fig. 11—Experiments in Phase Velocity and Field Distributions in a Guide (H_0 Wave).

on a wavelength of 25 mm; it may be seen at the left in Fig. 9, as also its power rack. Fig. 10 shows the receiver at the opposite end of the guide.

This demonstration equipment includes a number of devices developed in the course of investigations on dielectric guides. Before describing it in detail, certain work performed in the Lab-

oratories will be outlined in order to clarify the operation of the individual elements.

DETERMINATION OF PHASE VELOCITY

In experimental studies on guided waves it is frequently necessary to measure phase velocities or wavelengths along

the guide. As previously indicated, the equation whereby the phase velocity may be calculated is :

$$\left(\frac{f_c}{f}\right)^2 + \left(\frac{v}{v'}\right)^2 = 1$$

or, in a different form,

$$\left(\frac{\lambda}{\lambda_c}\right)^2 + \left(\frac{\lambda}{\lambda'}\right)^2 = 1 \dots\dots\dots(22)$$

λ , being the wavelength in a non-limited medium,
 $\epsilon \mu$;

λ_c , the cut-off wavelength in the same medium ;

λ' , the wavelength in the guide.

The cut-off wavelength, which depends on the diameter of the guide and the type of wave considered, can easily be obtained from Plate I

expressing the relation $\lambda_c = \frac{2\pi b}{r_n}$.

The roots r_n, r'_n of the Bessel functions, J and J' , have been classified by increasing orders of magnitude. The straight lines traced are relative to types of waves given by the first six roots.

The cut-off wavelength, λ_c , thus determined is the length corresponding to the dielectric medium of constants ϵ, μ utilized in the guide. If this dielectric medium differs from air, the corresponding cut-off wavelength in air (ϵ_0, μ_0) is obtained by multiplying λ_c by the ratio

$$\sqrt{\frac{\epsilon\mu}{\epsilon_0\mu_0}}$$

To determine rapidly the wavelength in the guide in specific cases as a function of the operating wavelength, or *vice versa*, equation (22) has been translated in the form shown in Plate II where the co-ordinates express the wavelength in relation to the diameter.

To each type of wave there corresponds a branch curve having for its asymptote the cut-off wavelength. The tangent at the origin for all the curves is a straight line inclined at 45° , corresponding to the wavelength in the free medium.

The experimental measurement of the wavelength in the guide is effected by producing stationary waves within the guide by reflection at the guide terminal.

If the end of the guide be closed by a perfectly conducting plane perpendicular to the axis, the incident wave gives rise by reflection to a wave

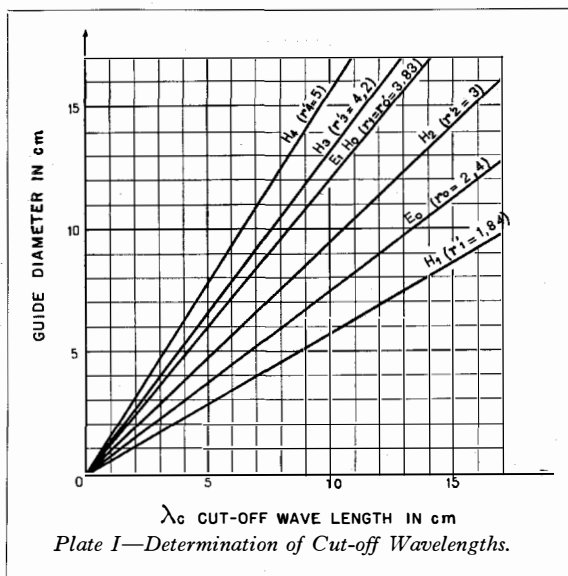

which is propagated in the reverse sense. This reflected wave is of the same type as the incident wave.

In effect, the variation along O_z of the different vectors may be expressed by the factor $e^{-j\gamma z}$, identical for all vectors. In other words, for a given type of wave, the relative field distribution corresponding to the points in a cross-section is maintained along the path of transmission ; i.e., all the vectors undergo the same variation of phase when passing from a plane Z_1 to a plane Z_2 . When reflection occurs on a plane perpendicular to the axis O_z , the components of the vectors $E_s, H_s, E_z,$ and H_z are subject only to variations of phase (perfect reflection). These variations of phase, which are identical for vectors of the same nature, are either zero or equal to π so that the relative de-phasing of vectors of different natures is maintained. Thus electric and magnetic vectors in the straight section E_s, H_s are always in phase. The vectors E_s simply change sign ; similarly the de-phasing of $\frac{\pi}{2}$ between transverse and axial vectors is maintained. The reflected wave is of the same nature as the incident wave. The superposition of the incident wave and the reflected wave gives a system of stationary waves characteristic of the type of wave under consideration. The position of the nodes and anti-nodes will now be sought :

- (1) Vectors subject to reflection without

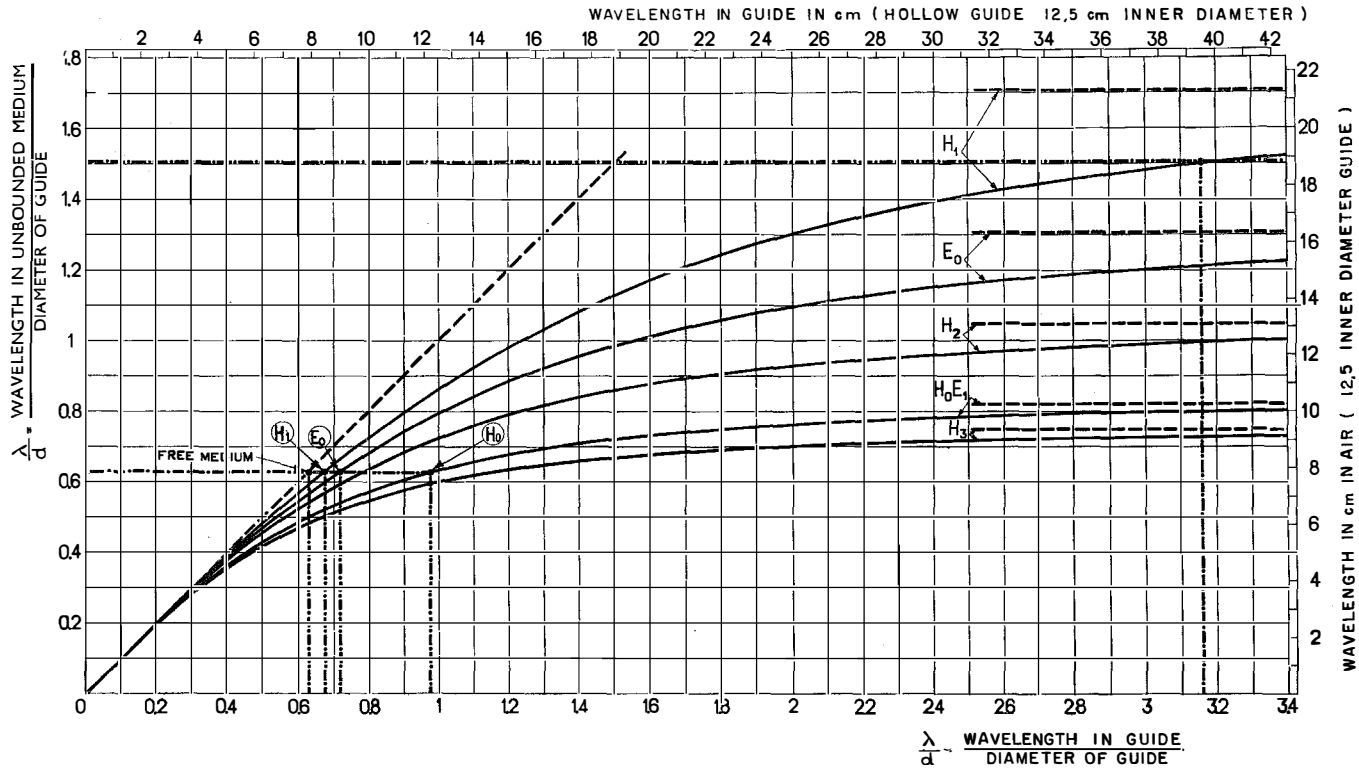
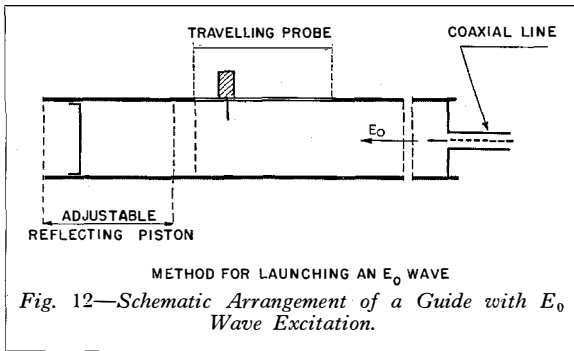

Plate II—Determination of Wavelengths in a Guide. Wavelengths in Free Medium and in the Guide are Plotted relatively to the Guide Diameter.



change of phase (vectors E_z, H_s). An incident vector of the form $Ae^{j(\omega t - \gamma z)}$ is superimposed on the vector $Ae^{j(\omega t + \gamma z)}$, the plane of reflection being taken as the origin for the z coordinates :

$$Ae^{j(\omega t - \gamma z)} + Ae^{j(\omega t + \gamma z)} = 2Ae^{j\omega t} \cos \gamma z = 2Ae^{j\omega t} \cos \frac{2\pi z}{\lambda'} \quad (23)$$

(2) Vectors subject to reflection with change of phase (vectors H_z, E_s); after superimposing :

$$Ae^{j(\omega t - \gamma z)} - Ae^{j(\omega t + \gamma z)} = -2Ae^{j\omega t} \sin \gamma z = -2Ae^{j\omega t} \sin \frac{2\pi z}{\lambda'} \quad (24)$$

E WAVES

The axial electric vector E_z is reflected without change of sign, the reflecting plane corresponding to a vector anti-node. In the case of the electric vector of the straight section E_s , on the other hand, the reflecting plane represents a node with the first anti-node $\frac{\lambda'}{4}$ in front of the reflecting plane.

The magnetic vector H_s has its nodes and anti-nodes on the same abscissa as the axial vector E_z . For example, for the E_0 wave the configuration of stationary waves corresponds to Fig. 2, in which the magnetic vectors undergo a displacement of $\frac{\lambda'}{4}$.

H WAVES

The magnetic axial vector H_z changes sign at the reflecting plane, which is a nodal point. It is an anti-node for the transverse magnetic vector H_s and a node for the transverse electric vector E_s . The configuration H_0 (Fig. 3) again represents a stationary state, provided the

electric vectors are displaced by $\frac{\lambda'}{4}$.

The phase velocity along the guide thus may be measured by the distance separating successive anti-nodes and nodes of one of the vectors.

Study of the stationary wave characteristics, moreover, gives valuable information on the emission of the different types of waves. It should be noted, in fact, that the theory outlined in the foregoing does not include the problem of the production of these types of waves, nor of coupling with the guide. This problem is essential to the experimenter and will be examined below.

EXCITATION OF E_0 WAVE

The configuration of the E_0 wave in the straight section is reminiscent of the coaxial wave. In both modes of propagation, the magnetic fields are circular and the electric fields radial (the relative distribution of the fields differs since the limiting conditions are dissimilar). The degree of relationship suggests the excitation of E_0 waves through a coaxial line, as represented diagrammatically in Fig. 12. Fig. 13 illustrates such an arrangement.

A small axial antenna fed by a coaxial line is passed through the centre of a cross-sectional plane closing the entrance to the guide. The electric and magnetic fields in the neighbourhood of this type of antenna appear substantially similar to the E_0 configuration. This method of excitation is fairly pure since, in a symmetrical arrangement, no other type of wave has a tendency to be generated. By changing the

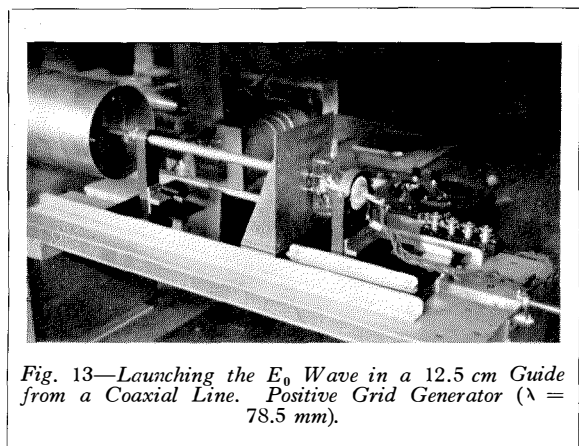

Fig. 13—Launching the E_0 Wave in a 12.5 cm Guide from a Coaxial Line. Positive Grid Generator ($\lambda = 78.5$ mm).

length of the axial antenna, it is possible to adjust the guide coupling to the source of emission. Closure of the extremity of the guide by a movable piston with a plane surface results in the production of stationary waves which may be studied by inserting a detector into the guide. Results of an experimental test with such a detecting device for a guide 125 mm in diameter and emission on a wavelength of 78.5 mm are given in Fig. 14, where the upper curve shows current variation as a function of the displacement of the detector along the guide for a given position of the reflecting piston. This curve illustrates the sinusoidal character of the variation of the transverse component of the electric field in accordance with equation (24).

Similarly, the value of the wavelength measured along the guide was 89.5 mm, which is in agreement with theory.

The lower curve of Fig. 14 was obtained by moving the reflecting piston, the position of the detector remaining fixed. Its configuration

indicates that the guide section considered functions as a high Q circuit. Resonance points determine guide lengths which are integral numbers of E_0 half-wavelengths. The wavelength is measured with much greater accuracy than in the previous case. The principle used may be adopted in the design of wavemeters. If the guide is damped, for example, through absorption of energy by means of a receiver at the end, the system becomes less selective and the curves, taken as a function of the displacement of the piston, are more rounded. Under these conditions, an interesting characteristic is revealed: besides the type of wave desired, indication is given of the coexistence in the guide of different types of waves due, in general, to deficiencies in the generating arrangement.

Fig. 15 illustrates an example of this phenomenon. The lower curve shows the detected current in a receiver E_0 , indicating the energy at the end of the guide as a function of its length. The upper curve was plotted from

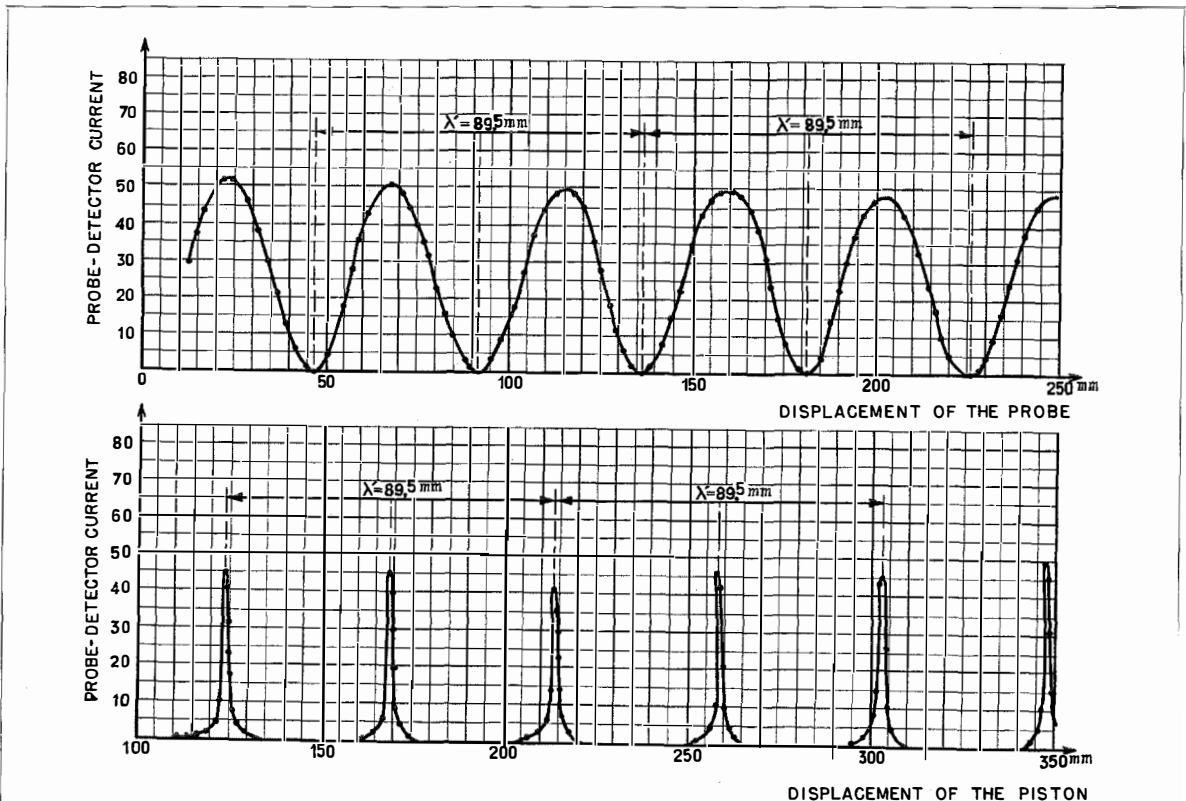

Fig. 14—Transverse Vector Distribution of an E_0 Wave along the Guide Axis (Upper Curve); and Amplitude Variation as a Function of the Resonance Chamber Length. Guide Diameter 125 mm ($\lambda = 78.5$ mm).

data obtained simultaneously, the current being detected by a small radial detector inserted into the guide (Fig. 16). The guide was 125 mm in diameter and the transmitter operated on a frequency of 2 370 Mc/s, corresponding in air to a wavelength of 126.5 mm. The current, as detected in the receiver, varied periodically with a periodicity of 100 mm corresponding to a wavelength of 200 mm in the guide—obviously the E_0 wave. Resonance was not very sharp, due to the damping caused by the receiver. On the other hand, the detector showed very selective maxima with a periodicity of 78.5 mm, corresponding exactly to H_1 wave in the guide at the same frequency. The receiver, being energized through an axial antenna, does not cause any damping in the guide except for the E_0 type of wave.

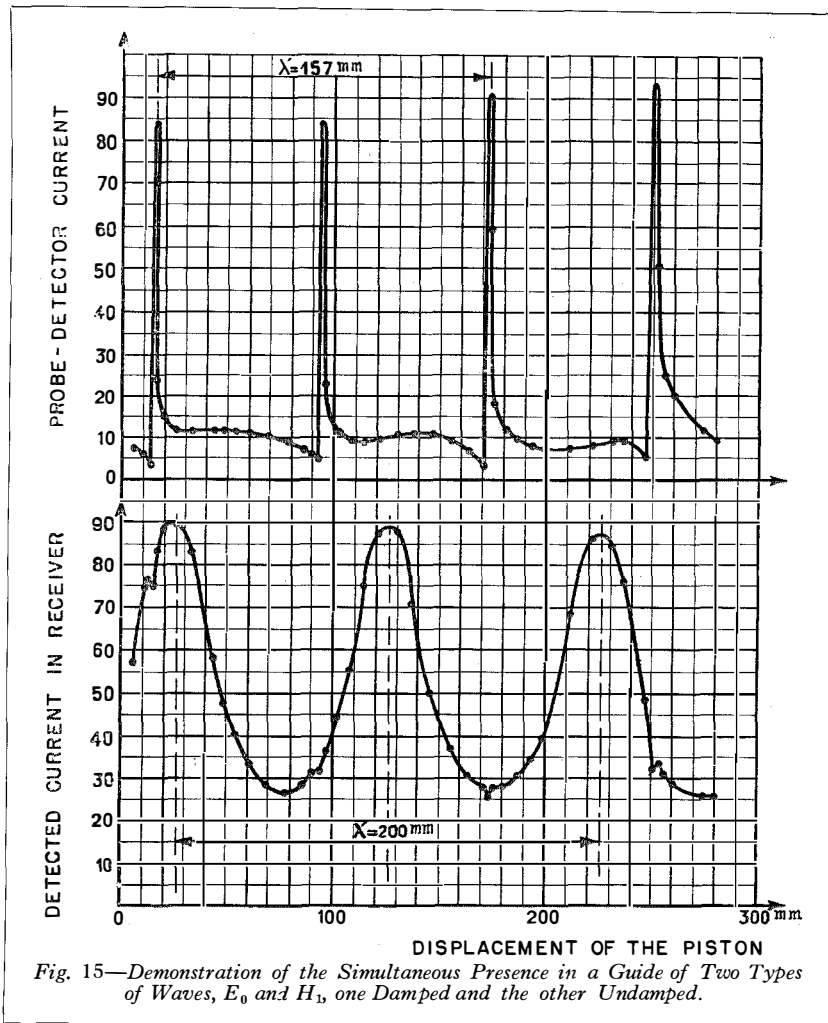

Fig. 15—Demonstration of the Simultaneous Presence in a Guide of Two Types of Waves, E_0 and H_1 , one Damped and the other Undamped.

The probe, however, is sensitive both to E_0 and H_1 waves (with the exception of H_1 waves the nodal line of which would be in the direction of the probe). The guide, for the wave H_1 , has no external damping; it acts, in this case, as a high Q circuit, capable

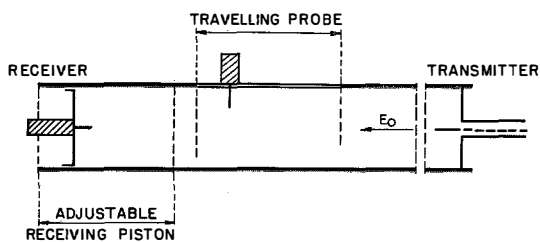

Fig. 16—Schematic of a Transmitter and Receiver (E_0 Wave). The Detector Reveals the Presence of an H_1 (Parasitic) Wave.

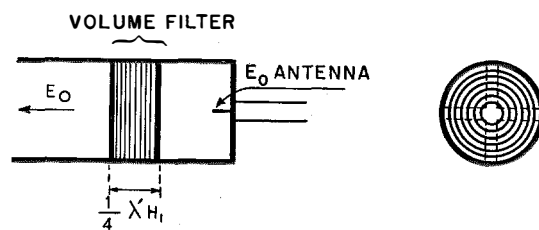

Fig. 17—Schematic of a Filter for Purifying E_0 Waves.

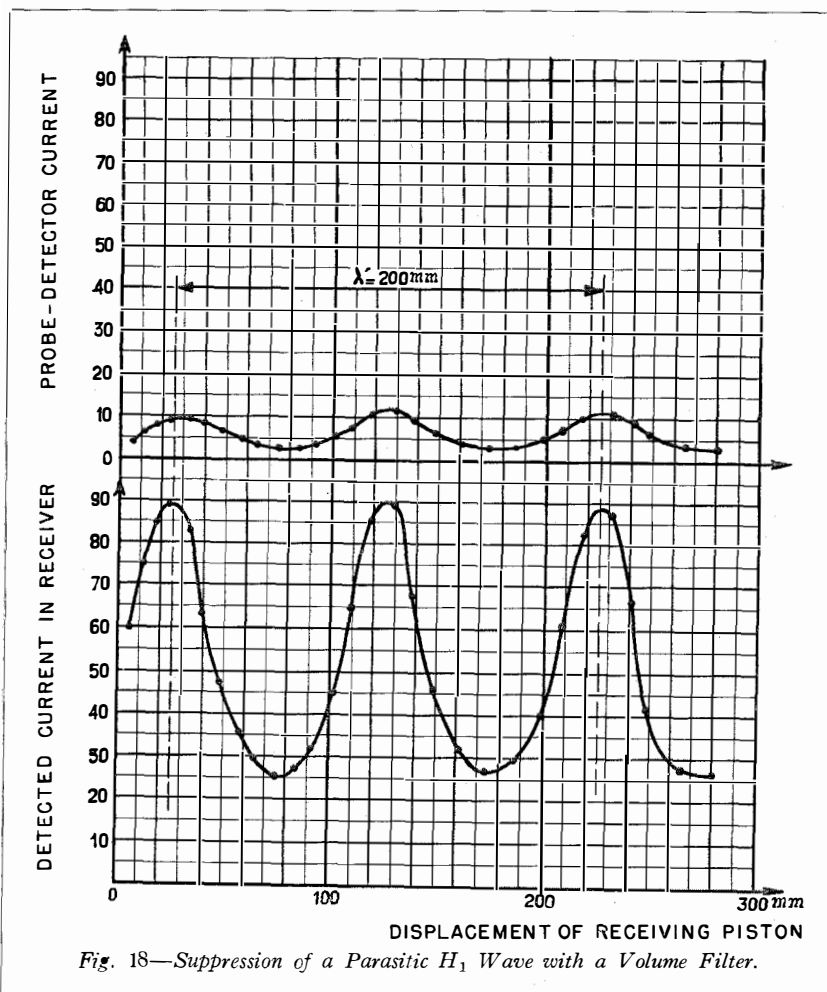

Fig. 18—Suppression of a Parasitic H_1 Wave with a Volume Filter.

of oscillating with considerable amplitudes on low excitations such, for example, as those which the deficiencies of the E_0 generating system may produce.

This clearly illustrates that it is possible for a section of the guide to possess very distinct simultaneous resonant characteristics for different types of waves. The impedance in the case of any particular guide section, is dependent on the specific wave structure.

VOLUME FILTERS

An attempt has been made to utilize this characteristic in guide sections which could be tuned separately for different types of waves. In effect, a plane metallic piston serves as a reflector for all types of waves. If the piston at the end of the guide be replaced by a plane

network composed of conducting wires, and if the electric lines of force be parallel to the conductor wires, reflection also occurs; if the lines of force be perpendicular to the wires, the wave crosses the network without noticeable alteration.

Combining this characteristic, due to the field configurations of the different types of waves, with the resonant effects due to different phase velocities, there are obtained circuit elements with interesting characteristics bearing on the separation of the different types of waves; and, in particular, on the generation of a purer wave of specific type. Consider a guide section limited on either side by two identical networks and place this section at the input of a guide of the same diameter; excitation with a wave with electric fields perpendicular

to the wires of the networks shows that the

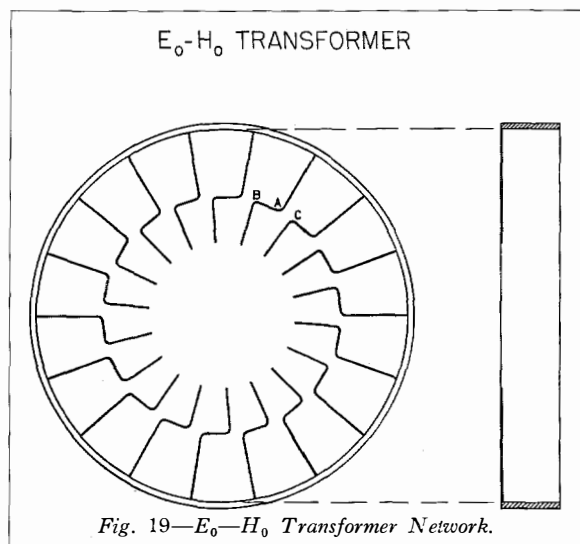

Fig. 19— E_0-H_0 Transformer Network.

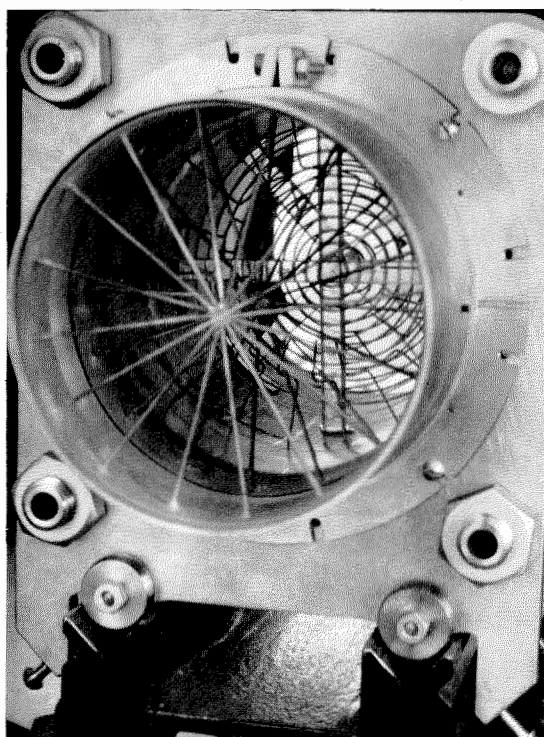

Fig. 20—Apparatus for Transforming the E_0 into the H_0 Wave. Propagation takes place towards the Front.

latter are practically without effect on this wave. For another wave, the required condition not being realized, the section of the guide limited by the networks will function as a resonance chamber; and, if this chamber be tuned to a quarter wavelength (or an uneven number of quarter wavelengths) of this type of wave, a high impedance effect will be presented, resulting in reflection. Such filters, designated as "volume filters" by the present authors, are very efficient. For example, referring to the experiment corresponding to Fig. 16 but placing ahead of the excitation antenna E_0 a guide section limited by two networks of circular conductors at a distance equal to a quarter H_1 wavelength (Fig. 17), and tracing the curves as a function of the displacement of the piston, the result reproduced on Fig. 18 is obtained. The E_0 wave crosses the volume filter without alteration; the H_1 wave, on the other hand, is stopped by the quarter wave circuit.

EXCITATION OF H_0 WAVE

Whilst one finds for the E_0 wave a relation-

ship with known methods of propagation, the same does not apply to the symmetrical magnetic wave H_0 which possesses a circular electric field and a radial magnetic field. A rational method of excitation for this type of wave would be a uniform circular current centred on the axis, as visualized in the method of excitation outlined by Southworth in the form of two semi-circles fed by a bi-filar line such that both currents have the same direction of rotation. If attempts be made to obtain greater current uniformity by increasing the number of circle arcs, it is necessary to increase proportionately the number of feed lines, the phase adjustment of which rapidly becomes extremely delicate; moreover, these feed lines themselves introduce disturbing interference. These considerations point to the development of an excitation system for H_0 waves free from these disadvantages.

The exciter adopted consists essentially of an interrupted circle formed of a large number of similar conductor arcs fed by radial wires placed in a field of configuration E_0 (Fig. 19). The radial elements are excited by the field of waves of E_0 origin, thus generating in the arcs of the circle equal currents of the same sense, suitable for the excitation of H_0 waves as confirmed by experiment. The system may be considered as a transformer of the E_0 wave into the H_0 wave.

Determination of the dimensions of this network depends on the following considerations:

- (a) The optimum diameter is that corresponding to the inversion of the axial magnetic field of the wave H_0 ;

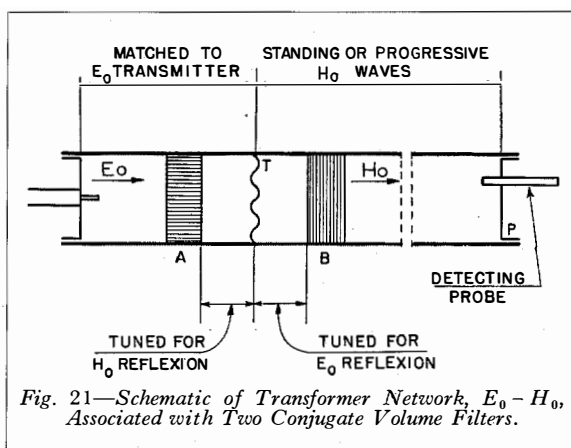

Fig. 21—Schematic of Transformer Network, $E_0 - H_0$, Associated with Two Conjugate Volume Filters.

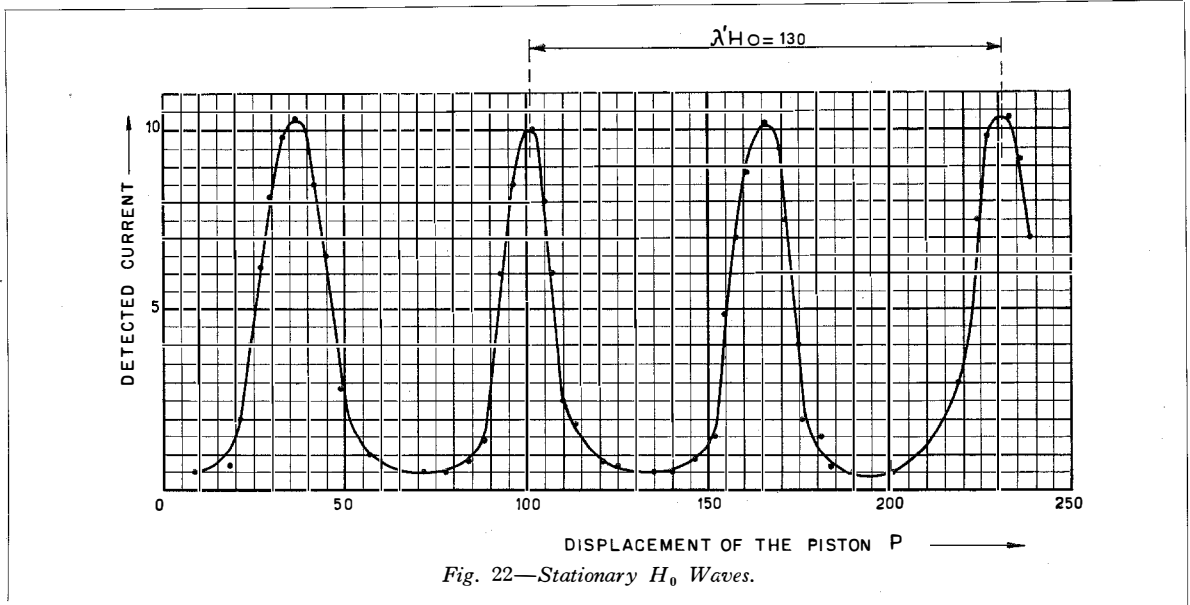

Fig. 22—Stationary H_0 Waves.

The axial component of the magnetic field H_0 is given by :

$$H_z = BJ_0(k\rho) e^{j(\omega t - \gamma z)}$$

J_0 becomes zero for $k\rho = 2.4$; and since $kb = 3.8$,

$$\rho = \frac{2.4}{3.8} b. \dots\dots\dots(25)$$

The maximum diameter of the circle of excitation is $\frac{2.4}{3.8} d$, d being the diameter of the guide ;

- (b) The length of the free ends corresponds with the existence of current anti-nodes on the arcs of the circle ;
- (c) The elementary arc length is less than a quarter wavelength in air ;
- (d) The separation of the elements is such that the space AC has an impedance definitely greater than the space AB .

The above points to the use of about twenty elementary arcs. But n arcs are capable of exciting E and H waves of order n . For $n = 20$, the cut-off frequencies are far removed from the frequencies used in the majority of cases and excitation cannot take place. It should be noted that in the construction of the transformer network no insulator is used ; further, the field configurations are substantially of the E_0 and the H_0 types. Radiation of both types due

to the transformer network takes place, however, in two directions along the guide. In order to separate the two types of radiation, a conjugate volume filters system is utilized. Fig. 20 shows a view of the complete equipment ; its schematic appears in Fig. 21.

Between the transformer network T and the E_0 transmitting antenna, a circular network volume filter, A, adjusted to a quarter wavelength H_0 , sends back that part of H_0 energy, which was propagated towards the transmitter, with a suitable phase. This filter passes E_0 waves. On the other side of the transformer a radial network volume filter, B, adjusted to the quarter wave E_0 transmits towards the transformer that part of the E_0 wave which would have a tendency to propagate itself in the guide. This filter, B, passes H_0 waves. Not only are

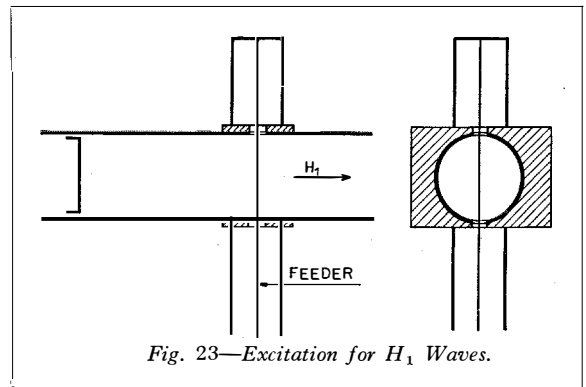

Fig. 23—Excitation for H_1 Waves.

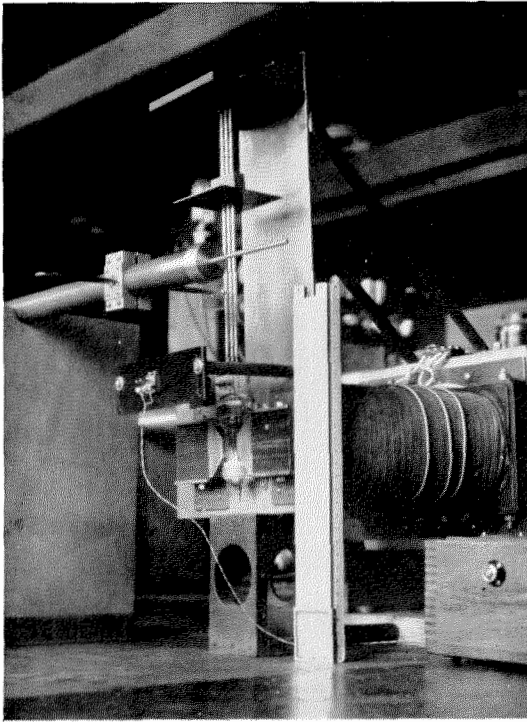

Fig. 24—Coupling for H_1 Waves of an Oscillating Magnetron (35 mm Wavelength) to a 23 mm Guide.

the E_0 and H_0 waves thus separated, but maximum efficiency of the transformer network is ensured.

The conjugate filters, A and B, are particularly suited to the transformation of E_0 , H_0 waves. These two waves are themselves conjugate, the lines of force of the one forming the orthogonal trajectories of the other.

The system was tested out under the following conditions :

Diameter of guide	..	125 mm
Transmitting wavelength		81 mm
Wavelength E_0	93 mm
Wavelength H_0	130 mm

The curve reproduced in Fig. 22 was plotted in a stationary condition, the detector being directed perpendicularly to a radius. Rotating this test around the axis of the guide, perfect circular symmetry was noted. Placing the detector along a radius for E_0 excitation, no current could be measured. Hence, an H_0 wave of great purity was obtained.

EXCITATION OF H_1 WAVE

The H_1 wave is unique in its low cut-off

frequency. Thus, for a given frequency, when the diameter of the guide is progressively diminished, a point is reached where the sole method of propagation possible is of the H_1 type.

The H_1 configuration suggests a type of excitation by means of a diametrical conductor, a piston reflector permitting all the energy to be transmitted in the direction desired (Fig. 23). This method of excitation can readily be effected with a coaxial or tri-filar line of which the central conductor only passes into the interior of the guide. The adjustment of this line on either side of the guide makes it possible to adapt the guide to the transmitter. The guide diameter along which the current is sent is entirely arbitrary. It determines the direction of polarization of the H_1 wave picked up at the receiver. Fig. 24 offers a practical example of a 23 mm diameter guide coupled to a magnetron oscillating on a 35 mm wavelength. For transmitting the H_1 wave in a guide equally suitable for other types of waves, use may advantageously be made of an intermediate section of guide of a smaller diameter to function as a filter and pass only H_1 waves.

TERMINATION ARRANGEMENTS

In general the structure used for transmitting a given type of wave may serve also for reception at the other end of the guide. In order to obtain a proper termination which will suppress the stationary waves, the entire incident energy must be taken from the guide. This energy may be radiated outside or dissipated in a receiver.

Figs. 25 and 26 illustrate the two cases. The system of Fig. 25 necessitates the successive adjustments of the interior axial antenna, the coaxial line and the exterior antenna. In the system in Fig. 26, the regulation of the axial

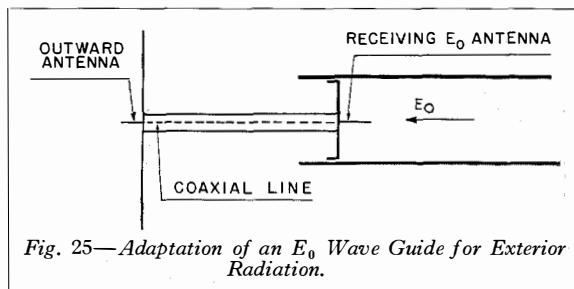
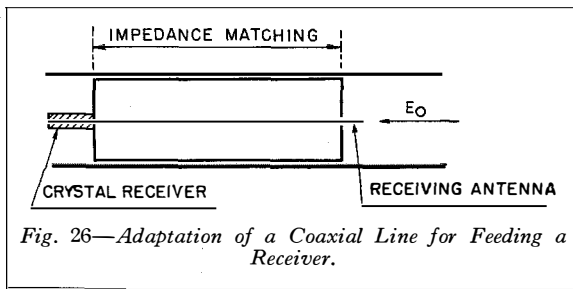

Fig. 25—Adaptation of an E_0 Wave Guide for Exterior Radiation.



antenna and the length of the coaxial line suffices. In order to control the adaptation, the receiver assembly is moved along the guide, the points of disappearance of the maxima and minima of stationary waves being noted.

IV.—DEMONSTRATION EQUIPMENT

The above outline of some of the processes and methods adopted in studies on wave guides will facilitate the description of the equipment employed to demonstrate the characteristic properties of this type of propagation: the phase velocity and the field configuration. Experiments included the three types of waves, E_0 , H_0 and H_1 .

The demonstration guide consisted of a copper tube 125 mm in interior diameter and about 1.50 m in length. The same transmitter was used for the three types of waves—a positive grid tube adjusted on a wavelength of 78.5 mm and modulated by a musical frequency. It is visible in Figs. 27, 28 and 29, including its bi-filar line terminated by a radiating doublet.

Fig. 27 shows the system generating a wave of the E_0 type. It is composed of a coaxial line coupled to the transmitter by a half-wave antenna. The central conductor of the coaxial line is prolonged and extends into the guide.

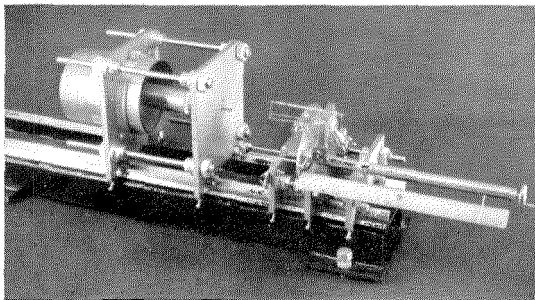

Fig. 27—Transmitter for E_0 Waves.

The wave obtained is filtered by a circular network volume filter.

On Fig. 28, in front of the transmitter, is the assembly used for the transmission of H_0 wave. As explained previously, an E_0 wave is produced initially and transformed into an H_0 wave by means of a wave transformer and a system of two conjugate volume filters. One of the elements of these filters may be seen in the illustration.

Fig. 29 shows the generator for H_1 waves. It is a 60 mm guide section which passes only H_1 waves. Coupling is effected by a slit which determines the diameter of polarization.

In the demonstration, the wavelengths in air and in the guide for the three types of waves were compared. A coaxial line wavemeter equipped with a crystal detector for measuring

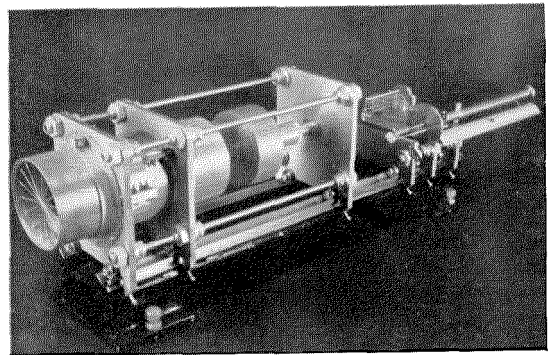

Fig. 28—Transmitter for H_0 Waves.

the wavelength in air may be noted on the side of the transmitter tube of Figs. 27, 28 and 29. This wavemeter operates on the principle of stationary waves produced inside the coaxial line by a short circuited piston. When the position of the piston corresponds to an anti-node in the detector, the current attains maximum value; after amplification, it is fed into a small lamp. By means of rods the movement of the lamp is made to correspond to that of the adjustable piston of the wavemeter (Fig. 11).

Above this lamp, a second one is connected to a reflecting piston at the end of the guide and fed by the current previously amplified through a detector associated with the moving piston. The wavelengths are compared in the following manner.

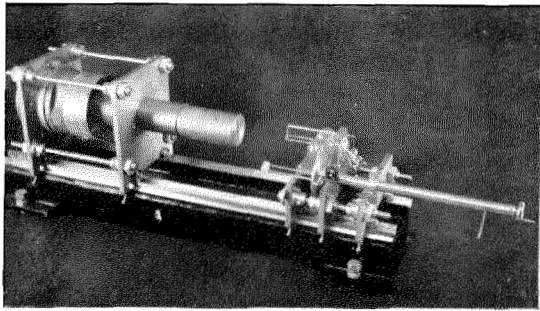

Fig. 29—Transmitter for H_1 Waves.

By moving the wavemeter the lower lamp progresses in front of a graduated scale and lights up at every half wave. Thus the wavelength in air may be measured. An exact reading gives 78.5 mm.

The piston is then moved to the end of the guide and the upper lamp is seen to move and light up, the intervals corresponding to half wavelengths in the guide. The wavelength in the guide is always greater than in air.

The values determined were :

Wave E_0	89.5 mm
Wave H_0	122 mm
Wave H_1	84.5 mm

They are in agreement with the computed values, as given in Plate II.

The field distributions for each type of wave are given by means of the apparatus of Fig. 30. It consists essentially of a section of tube 125 mm in diameter, inside which a plane reflecting piston slides. From this piston a small protruding probe feeds a crystal detector. The piston is part of a movable truck on rails paralleling the axis of the guide ; this longitudinal movement makes it possible to measure the guide wavelengths, the detector indicating the stationary wave condition.

In a given position of the truck, manipulation of a hand wheel results in a rotary movement which enables the probe to explore the field over a complete circumference centred on the axis. This movement is transmitted to a representative probe made of two small lamps in front of a panel representing the lines of force of the type of wave under study.

In order to experiment with the E_0 wave, for example, the probe at the reflecting piston is given a direction following the radius of the

cylinder ; the representative probe is placed correspondingly. Having excited the guide with E_0 waves, the piston is adjusted to maximum brightness of the small lamps fed, after amplification, by the current picked up by the detector. Then, by manipulating the hand wheel, the probe and the lamps rotate simultaneously, the flash of the latter making it possible to explore the field. In the present case their constant brightness demonstrated the perfectly uniform circular distribution of the radial field, characteristic of the E_0 wave.

After having substituted the transmitting device for E_0 by that for H_0 and given the probe a direction perpendicular to the radius, the exploration was repeated. It again showed a perfectly uniform distribution of the circular electric field.

Another substitution was made for the H_1 wave. The detector, rotating around the axis, lights up and is extinguished twice in a complete rotation, thus showing the diameter of polarization characteristic of this type of wave.

This series of tests having demonstrated an experimental realization of individually different types of waves postulated by theory, another

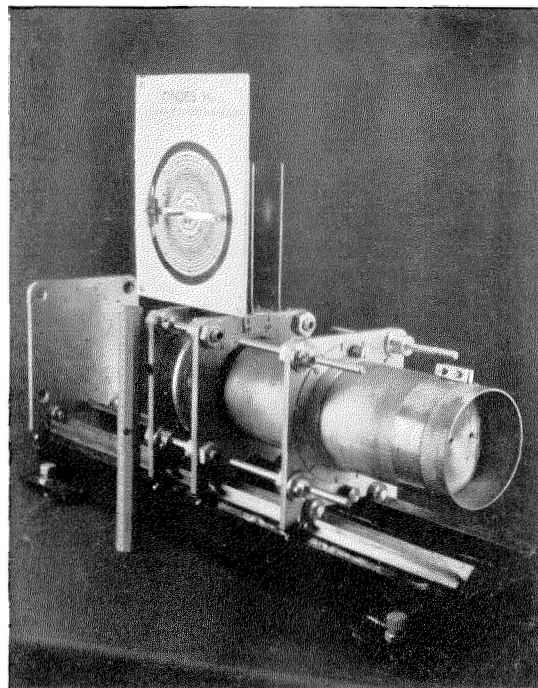

Fig. 30—Receiving Side of a 12.5 cm Guide with Means for Demonstrating the Distribution of Electric Lines of Force for Different Types of Waves.

experiment showed the possibility of transmitting these guided waves in cables of practical commercial size: 25 mm H_1 waves (12 000 Mc/s) were propagated in a copper tube of 16 mm inside diameter. The guide was 5 m in length.

The transmitting side is shown in Fig. 31. As may be seen, the entrance of the guide is coupled to the tri-filar line of a magnetron tube placed between the poles of an electro-magnet. On the left, mounted on a conical support, is a small coaxial line wavemeter, which is a reduced model of the wavemeter used on 8 cm wavelengths, and which serves as transmitter control apparatus. The operation of a handle moves the small lamp which lights every 12.5 mm under the influence, after detection and amplification, of the modulated wave emitted by the magnetron.

The guide, as illustrated in Fig. 32, is terminated by a detector corresponding to the diameter of polarization and is followed by a movable reflecting piston. A small lamp indicates the current picked up by the receiver. It moves with the piston and thus measures the wavelength in the guide (54 mm as shown in Fig. 11). The large increase in wavelength is due to the proximity of the applied and cut-off frequencies.

The above description is limited to aspects of apparatus relating to the centimetre wave technique as applied to dielectric guides. Obviously, special attention must be devoted to the feeding of the transmitter valves. In particular, the stability of the emitted frequency

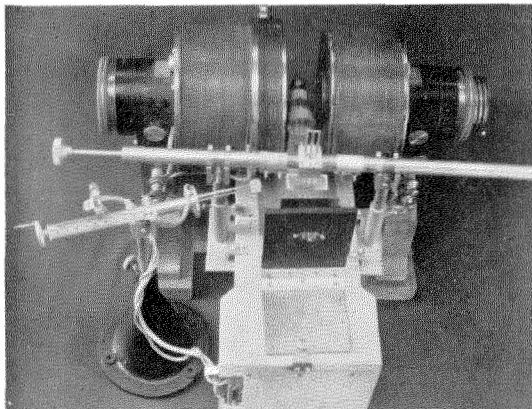

Fig. 31—25 mm Wavelength Transmitter and Coupling to a 16 mm Guide. At the Left is a Control Wavemeter.

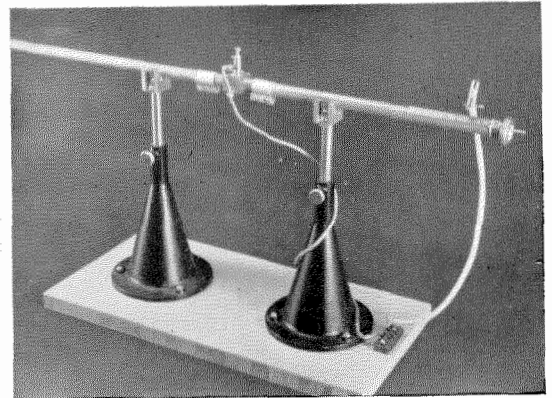

Fig. 32—Crystal Receiver Mounted on a 16 mm Guide.

is directly dependent on the sources of supply; accuracy of sources of supply achieved in these demonstrations was of the order of one in ten-thousand.

V.—ATTENUATION COEFFICIENTS

In the foregoing demonstrations, it was possible to verify the agreement between theoretical conclusions and experimental facts, whilst giving an indication of aspects of this new technique utilizing centimetre electromagnetic waves. One question of particular interest to engineers dealing with transmission remains to be examined, i.e., the attenuation of a progressive wave in the course of its propagation along the dielectric guide. For the calculation of attenuation coefficients reference may be made to previous publications. The following are the most important conclusions.

Considering copper losses alone, attenuation in the case of a coaxial cable increases proportionately to the square root of the frequency. In the dielectric guide there is a minimum attenuation frequency for the E_0 wave, and the ratio m of this optimum frequency to the cut-off frequency is equal to $\sqrt{3}$. The wave H_1 also presents minimum attenuation when the ratio m is equal to 3.15.

Finally, the wave H_0 behaves uniquely. For this type of wave, the transverse magnetic vector H_s has zero value at the surface of the conductor; no current flows in the copper in the axial direction, but only circularly. When the value of the mean energy flux is constant in the straight section, the circular current (which is dependent on the axial magnetic field H_z on

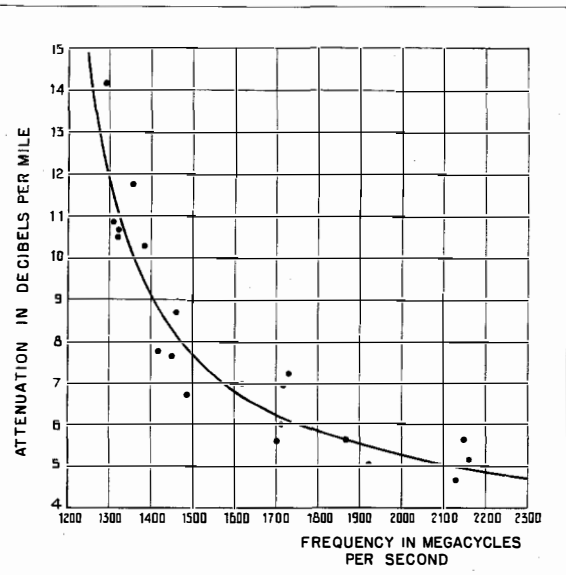

Fig. 33—Attenuation of H_1 Waves in a Copper Tube 15 cm in Diameter. The Curve is Calculated, the Dots are Experimental (Southworth's Results).

frequency increases. Thus H_0 is a wave structure of which the attenuation coefficient due to copper losses decreases as the frequency increases.

The attenuation coefficients calculated above relate only to losses in the copper. In the case of the coaxial cable, a coefficient of attenuation due to losses in the insulation must be added.

In dielectric guides, the dielectric losses are practically negligible if air is used as the medium of propagation. Consideration might be given to the employment of a dielectric other than air, thus making it possible, for a given frequency, to reduce the guide diameter. A supplementary attenuation coefficient, however, would be introduced; even with the best known dielectrics it would be very much greater than the coefficient due to copper losses so that, at present, it is not possible to visualize any dielectric other than dry air.

For the case of the dielectric guide with a copper sheath of a resistance equal to 1724 E.M.U., the results of calculations are given in Plate III. Comparisons are made of values relating to the following cases: E_0 waves with minimum attenuation ($m = \sqrt{3}$); H_1 approximating minimum attenuation ($m = 3$); and,

the surface) decreases as the frequency increases. It even tends towards zero at very high frequencies since H_z , which is a component not linked up with the transmission of energy in the direction of the axis, approaches zero as the

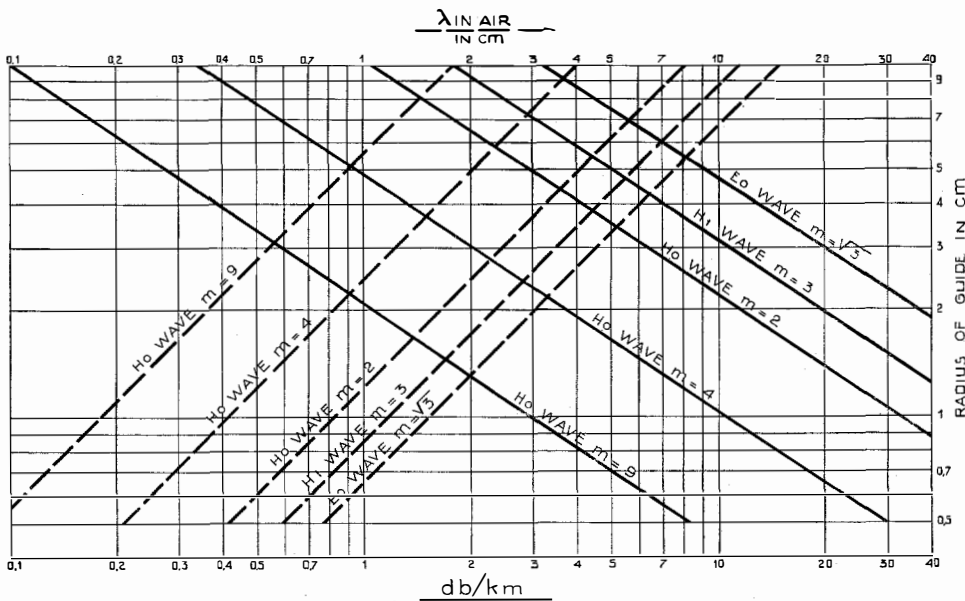
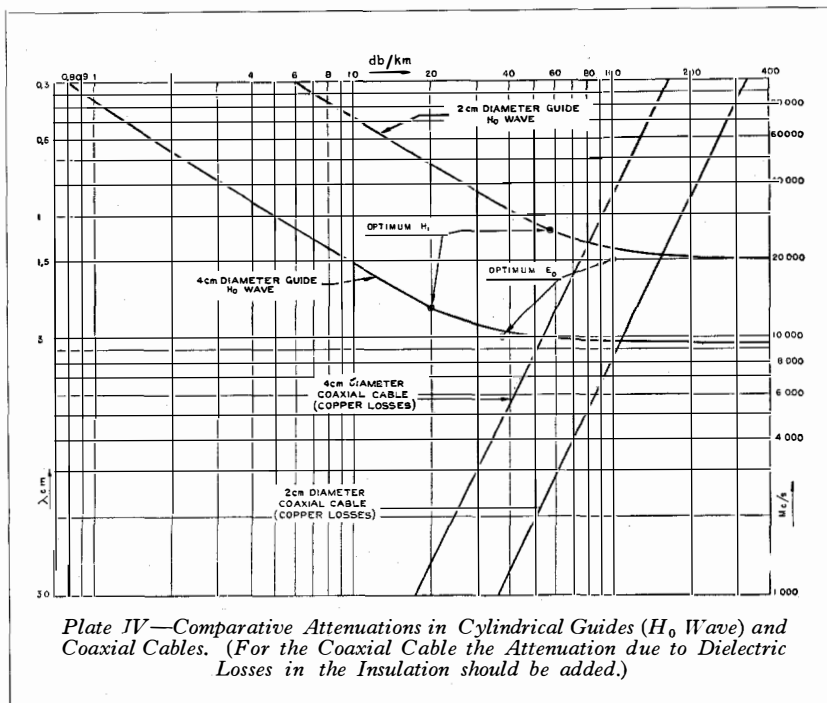

Plate III—Optimum Operating Wavelengths of Different Types Versus Guide Radius (broken lines), and Corresponding Attenuation due to Copper Loss (full lines).



finally, H_0 for the parameters $m = 2, 4$ and 9 . They give an indication of the orders of magnitude involved.

From Plate III, for example, it will be seen that in a guide with a radius of 1.5 cm, the E_0 wave yields an attenuation of 58 db. per km; the wavelength is 2.3 cm. For the optimum H_1 wave (1.75 cm), the attenuation is 30 db. per km.

For the same guide radius, the wave H_0 is capable of yielding values which are clearly lower, provided that it is found practicable to produce and utilize sufficiently high frequencies. The following values apply :

$$\begin{aligned} \text{for } \lambda &= 1.25 \text{ cm, } \alpha = 18 \text{ db./km} \\ \lambda &= 0.6 \text{ cm, } \alpha = 6 \text{ db./km} \\ \lambda &= 0.3 \text{ cm, } \alpha = 1.8 \text{ db./km} \end{aligned}$$

These values are the results of calculation ; the experimental verifications are not, as yet, far advanced. Southworth, nevertheless, has made tests on a guide 15 cm in diameter and 550 m in length. The results, with an H_1 wave between 1 200 and 2 200 Mc/s, are given by Fig. 33.

Finally Plate IV gives a comparison of the theoretical attenuations incurred in coaxial cable and dielectric guides. The coaxial cable

employs relatively low frequencies ; the guide, relatively high ones. It must not be forgotten that the merits of the very high frequency guide are emphasized by consideration of the losses produced by insulation in coaxial cable ; such losses become important at very high frequencies but do not occur in dielectric guides.

VI.—CONCLUSION

Guided electro-magnetic waves offer a new transmission method, the study of which is in its infancy. A forecast as to the extent such guided waves will find commercial application

certainly would be premature. Characteristics disclosed by theory and confirmed by experiment, and in particular those presented by the H_0 wave structure, in any case, are important. Assuming continued progress in centimetre wave technique, interesting developments seem assured.

BIBLIOGRAPHY

- LORD RAYLEIGH : "The Passage of Electric Waves through Tubes, or the Vibrations of Dielectric Cylinders," *Philosophical Magazine*, 1897, Vol. 43, pp. 125-132.
- D. HONDROS and P. DEBYE : "Elektromagnetische Wellen an Dielektrischen Drähten," *Annalen der Physik*, 1910, Vol. 32, pp. 465-476.
- H. ZAHN : "Über den Nachweis Elektromagnetischer Wellen an Dielektrischen Drähten," *Annalen der Physik*, 1916, Vol. 49, pp. 907-933.
- O. SCHRIEVER : "Elektromagnetische Wellen an Dielektrischen Drähten," *Annalen der Physik*, 1920, Vol. 63, pp. 645-673.
- J. R. CARSON : "Guided and Radiated Energy in Wire Transmission," *Journal of A.I.E.E.*, 1924, Vol. 43, October, pp. 908-913.
- A. G. CLAVIER : "Production and Utilization of Micro-Rays," *Electrical Communication*, 1933, July, pp. 8-11.
- A. G. CLAVIER and L. C. GALLANT : "The Anglo-French Micro-Ray Link between Lympe and St. Inglevert," *Electrical Communication*, 1934, January, pp. 222-228.
- G. C. SOUTHWORTH : "Hyper-Frequency Wave Guides—General Considerations and Experimental

Results," *Bell System Technical Journal*, 1936, April, pp. 284-309.

J. R. CARSON, SALLIE P. MEAD and S. A. SCHELKUNOFF: "Hyper-Frequency Wave Guides—Mathematical Theory," *Bell System Technical Journal*, 1936, April, pp. 310-333.

L. BRILLOUIN: "Propagation d'ondes Électromagnétiques dans un Tuyau," *Revue Générale de l'Électricité*, 1936, Vol. 22, August, pp. 227-239.

W. L. BARROW: "Transmission of Electromagnetic Waves in Hollow Tubes of Metal," *Proceedings of I.R.E.*, 1936, Vol. 24, pp. 1298-1328.

LEIGH PAGE and N. I. ADAMS, Jr.: "Electromagnetic Waves in Conducting Tubes," *Physical Review*, 1937, Vol. 52, pp. 647-651.

S. A. SCHELKUNOFF: "Transmission Theory of Plane Electromagnetic Waves," *Proceedings of I.R.E.*, 1937, Vol. 25, pp. 1457-1491.

A. G. CLAVIER: "Théorie des Câbles Diélectriques Cylindriques et Relations avec la Théorie des Câbles Coaxiaux," *Sté. Française des Electriciens*, 1938, Vol. 8 (5th series), April, pp. 355-388.

J. SAPHORES: "General Properties of Dielectric Guides," *Electrical Communication*, 1938, Vol. 16, April, pp. 346-349.

L. BRILLOUIN: "Theoretical Study of Dielectric Cables," *Electrical Communication*, 1938, Vol. 16, April, pp. 350-372.

W. L. BARROW and F. M. GREENE: "Rectangular Hollow-Pipe Radiators," *Proceedings of I.R.E.*, 1938, Vol. 26, December, pp. 1498-1519.

W. L. BARROW and L. J. CHU: "Electromagnetic Waves in Hollow Metal Tubes of Rectangular Cross Section," *Proceedings of I.R.E.*, 1938, Vol. 26, December, pp. 1520-1555.

THE BRITISH BROADCASTING CORPORATION'S START POINT TRANSMITTER.

The view on the right shows the transmitter hall from the gallery, with the transmitter (right), control desk (centre), and modulation transformer and plate feed reactors (left). Pictured below is the vault beneath the transmitter hall with valve-cooling water pumps and high tension enclosure in the background.

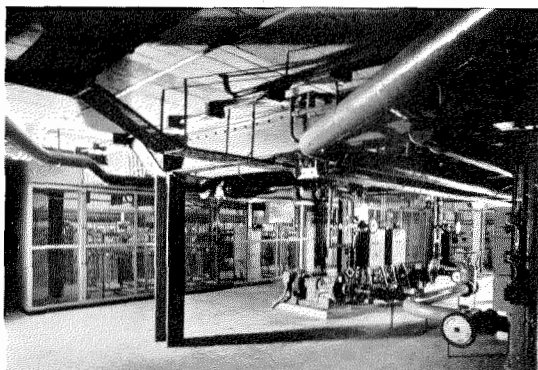

[Photographs reproduced by courtesy of the British Broadcasting Corporation.]

THE Start Point, South Devon, 100 kW transmitter (285.7 m) and also the 20 kW Clevedon, Somerset, transmitter (203.5 m) were inaugurated simultaneously by His Grace the Duke of Somerset, on June 14th, 1939, and are intended to serve the whole area of South-West England. They employ class "B" modulation with negative feedback so that the total harmonic content amounts to not more than 2.5 per cent. at 90 per cent. modulation.

The transmitter and valves for both stations were supplied by Standard Telephones and Cables Limited, London, together with the dry-metal rectifiers used for operating the station relay system. In addition, in the case of Clevedon, S.T.C. supplied the power and water cooling plant and auxiliaries for the station, including the 9 500-volt H.C.M.V. rectifier for the high tension supply.

Telephone and Telegraph Statistics of the World

Compiled by Chief Statistician's Division, American Telephone and Telegraph Company

Telephone Development of the World, by Countries January 1, 1938

COUNTRIES	NUMBER OF TELEPHONES			Per Cent of Total World	Telephones Per 100 Population
	Government Systems	Private Companies	Total		
NORTH AMERICA :					
United States.....	—	19 453 401	19 453 401**	49.57%	15.09
Canada.....	199 150	1 123 644	1 322 794	3.37%	11.90
Central America.....	12 520	16 033	28 553	0.07%	0.40
Mexico.....	1 337	136 744	138 081	0.35%	0.72
West Indies—					
Cuba.....	610	50 553	51 163	0.13%	1.15
Puerto Rico.....	531	14 640	15 171	0.04%	0.85
Other W. I. Places.....	9 015	16 943	25 958	0.07%	0.36
Other No. Am. Places.....	—	14 900	14 900	0.04%	4.13
Total.....	223 163	20 826 858	21 050 021	53.64%	11.68
SOUTH AMERICA :					
Argentina.....	—	377 473	377 473	0.96%	2.96
Bolivia.....	—	2 555	2 555	0.007%	0.08
Brazil.....	958	240 603	241 561	0.62%	0.47
Chile.....	—	70 867	70 867	0.18%	1.54
Colombia.....	8 500	30 259	38 759	0.10%	0.39
Ecuador.....	4 267	2 816	7 083	0.02%	0.28
Paraguay.....	—	3 133	3 133	0.01%	0.33
Peru.....	—	25 981	25 981	0.07%	0.39
Uruguay.....	32 823	11 245	44 068	0.11%	2.11
Venezuela.....	805	20 253	21 058	0.05%	0.61
Other So. Am. Places.....	2 869	—	2 869	0.007%	0.52
Total.....	50 222	785 185	835 407	2.13%	0.86
EUROPE :					
Austria.....	281 790	—	281 790	0.72%	4.12
Belgium†.....	393 528	—	393 528	1.00%	4.70
Bulgaria.....	25 532	—	25 532	0.07%	0.40
Czecho-Slovakia.....	220 510	—	220 510	0.56%	1.43
Denmark.....	17 950†	408 001	425 951	1.09%	11.25
Finland.....	6 743	164 998	171 741	0.44%	4.48
France.....	1 552 618	—	1 552 618	3.96%	3.70
Germany†.....	3 623 697	—	3 623 697	9.23%	5.31
Great Britain and No. Ireland.....	3 029 456	—	3 029 456	7.72%	6.41
Greece.....	6 780	36 774	43 554	0.11%	0.62
Hungary.....	148 595	744	149 339	0.38%	1.65
Ireland (Eire)†.....	40 403	—	40 403	0.10%	1.36
Italy.....	—	600 501	600 501	1.53%	1.38
Jugo-Slavia.....	59 022	—	59 022	0.15%	0.38
Latvia†.....	77 230	—	77 230	0.20%	3.90
Lithuania.....	22 042	—	22 042	0.06%	0.87
Netherlands.....	401 484	—	401 484	1.02%	4.65
Norway*.....	135 007	87 003	222 010	0.57%	7.61
Poland.....	146 562	125 738	272 300	0.69%	0.79
Portugal.....	17 115	47 426	64 541	0.16%	0.87
Roumania.....	—	81 205	81 205	0.21%	0.41
Russia□.....	950 000	—	950 000	2.42%	0.53
Spain.....	—	300 000	300 000	0.76%	1.20
Sweden.....	737 102	1 596	738 698	1.88%	11.75
Switzerland.....	430 877	—	430 877	1.10%	10.26
Other Places in Europe.....	91 201	—	91 201	0.23%	1.76
Total.....	12 415 244	1 853 986	14 269 230	36.36%	2.47
ASIA :					
British India†.....	31 075	49 156	80 231	0.20%	0.02
China.....	80 000	90 000	170 000	0.43%	0.04
Japan†.....	1 304 693	—	1 304 693	3.33%	1.82
Other Places in Asia.....	172 583	93 684	266 267	0.68%	0.14
Total.....	1 588 351	232 840	1 821 191	4.64%	0.17
AFRICA :					
Egypt.....	60 546	—	60 546	0.16%	0.27
Union of South Africa†.....	189 601	—	189 601	0.48%	1.90
Other Places in Africa.....	121 014	2 094	123 108	0.31%	0.10
Total.....	371 161	2 094	373 255	0.95%	0.24
OCEANIA :					
Australia*.....	594 855	—	594 855	1.51%	8.71
Hawaii.....	—	30 794	30 794	0.08%	7.62
Netherlands East Indies.....	41 581	4 128	45 709	0.12%	0.07
New Zealand†.....	192 020	—	192 020	0.49%	11.97
Philippine Islands.....	1 256	26 651	27 907	0.07%	0.19
Other Places in Oceania.....	4 351	329	4 680	0.01%	0.19
Total.....	834 063	61 902	895 965	2.28%	0.93
TOTAL WORLD.....	15 482 204	23 762 865	39 245 069§	100.00%	1.79

* June 30, 1937.

† February 28, 1938.

‡ March 31, 1938.

** As reported by the United States Department of Commerce, Bureau of the Census.

□ U.S.S.R., including Siberia and Associated Republics. (Estimated)

§ Includes approximately 20 000 automatic or "Dial" telephones, of which about 42% are in the United States.

Telephone and Telegraph Wire of the World, by Countries
January 1, 1938

COUNTRIES	Service Operated by (See Note)	MILES OF TELEPHONE WIRE			MILES OF TELEGRAPH WIRE		
		Number of Miles	Per Cent of Total World	Per 100 Population	Number of Miles	Per Cent of Total World	Per 100 Population
NORTH AMERICA :							
United States.....	P.	90 831 000	53.88%	70.47	2 320 000	33.83%	1.80
Canada.....	P.G.	5 308 000	3.15%	47.73	363 000	5.29%	3.26
Central America.....	P.G.	62 000	0.04%	0.86	22 000	0.32%	0.31
Mexico.....	P.	582 000	0.35%	3.04	100 000	1.46%	0.52
West Indies—							
Cuba.....	P.	278 000	0.17%	6.24	12 000	0.18%	0.27
Puerto Rico.....	P.	38 000	0.02%	2.12	2 000	0.03%	0.11
Other W. I. Places.....	P.G.	109 000	0.06%	1.51	9 000	0.13%	0.12
Other No. Am. Places.....	P.	22 000	0.01%	6.09	11 000	0.16%	3.05
Total.....		97 230 000	57.68%	53.77	2 839 000	41.40%	1.58
SOUTH AMERICA :							
Argentina.....	P.	1 480 000	0.88%	11.63	160 000	2.33%	1.25
Bolivia.....	P.	5 500	0.003%	0.17	5 000	0.07%	0.16
Brazil.....	P.	1 025 000	0.61%	2.01	110 000	1.61%	0.22
Chile.....	P.	282 000	0.17%	6.13	30 000	0.44%	0.65
Colombia.....	P.G.	159 000	0.09%	1.59	22 000	0.32%	0.22
Ecuador.....	P.G.	9 000	0.01%	0.36	4 000	0.06%	0.16
Paraguay.....	P.	7 500	0.004%	0.79	3 000	0.04%	0.32
Peru.....	P.	89 000	0.05%	1.33	13 000	0.19%	0.19
Uruguay.....	P.G.	158 000	0.09%	7.55	8 000	0.12%	0.38
Venezuela.....	P.	100 000	0.06%	2.92	7 000	0.10%	0.20
Other So. Am. Places.....	G.	6 000	0.004%	1.08	500	0.01%	0.09
Total.....		3 321 000	1.97%	3.40	362 500	5.29%	0.37
EUROPE :							
Austria.....	G.	677 000	0.40%	9.90	48 000	0.70%	0.70
Belgium.....	G.	1 944 000	1.15%	23.24	35 000	0.51%	0.42
Bulgaria.....	G.	79 000	0.05%	1.25	5 500	0.08%	0.09
Czecho-Slovakia.....	G.	700 000	0.41%	4.55	85 000	1.24%	0.55
Denmark.....	P.	1 430 000	0.85%	37.78	9 000	0.13%	0.24
Finland.....	P.	299 000	0.18%	7.80	22 000	0.32%	0.57
France.....	G.	5 861 000	3.48%	13.97	319 000	4.65%	0.76
Germany†.....	G.	17 030 000	10.10%	24.97	182 000	2.65%	0.27
Great Britain and No. Ireland†.....	G.	14 086 000	8.35%	29.81	243 000	3.54%	0.51
Greece.....	P.G.	147 000	0.09%	2.10	37 000	0.54%	0.53
Hungary.....	G.	435 000	0.26%	4.81	46 000	0.67%	0.51
Ireland (Eire)†.....	G.	134 000	0.08%	4.52	22 000	0.32%	0.74
Italy.....	P.	1 631 000	0.97%	3.74	276 000	4.02%	0.63
Jugo-Slavia.....	G.	145 000	0.09%	0.94	58 000	0.85%	0.38
Latvia†.....	G.	310 000	0.18%	15.65	4 500	0.07%	0.23
Lithuania.....	G.	78 000	0.05%	3.07	2 500	0.04%	0.10
Netherlands.....	G.	1 300 000	0.77%	15.05	10 000	0.15%	0.12
Norway*.....	P.G.	688 000	0.41%	23.59	22 000	0.32%	0.75
Poland.....	P.G.	998 000	0.59%	2.89	49 000	0.71%	0.14
Portugal.....	P.G.	174 000	0.10%	2.33	14 000	0.20%	0.19
Roumania.....	P.	389 000	0.23%	1.96	47 000	0.69%	0.24
Russia‡.....	G.	1 500 000	0.89%	0.83	600 000	8.75%	0.33
Spain.....	P.	1 500 000	0.89%	6.00	90 000	1.31%	0.36
Sweden.....	G.	2 796 000	1.66%	44.49	17 000	0.25%	0.27
Switzerland.....	G.	1 530 000	0.91%	36.43	12 000	0.18%	0.29
Other Places in Europe.....	G.	290 000	0.17%	5.60	13 000	0.19%	0.25
Total.....		56 151 000	33.31%	9.71	2 268 500	33.08%	0.39
ASIA :							
British India†.....	P.G.	500 000	0.30%	0.14	424 000	6.19%	0.12
China.....	P.G.	650 000	0.38%	0.14	130 000	1.90%	0.03
Japan†.....	G.	4 733 000	2.81%	6.60	234 000	3.41%	0.33
Other Places in Asia.....	P.G.	854 000	0.51%	0.46	221 000	3.22%	0.12
Total.....		6 737 000	4.00%	0.62	1 009 000	14.72%	0.09
AFRICA :							
Egypt.....	G.	325 000	0.19%	1.48	36 000	0.52%	0.16
Union of South Africa†.....	G.	721 000	0.43%	7.21	31 000	0.45%	0.31
Other Places in Africa.....	G.	353 000	0.21%	0.23	150 000	2.19%	0.12
Total.....		1 399 000	0.83%	0.91	217 000	3.16%	0.14
OCEANIA :							
Australia*.....	G.	2 670 000	1.58%	39.09	106 000	1.54%	1.55
Hawaii.....	P.	103 000	0.06%	25.50	0	0.00%	0.00
Netherlands East Indies.....	G.	251 000	0.15%	0.36	20 000	0.29%	0.03
New Zealand†.....	G.	627 000	0.37%	39.09	21 000	0.31%	1.31
Philippine Islands.....	P.	72 000	0.04%	0.50	10 000	0.15%	0.07
Other Places in Oceania.....	G.	12 000	0.01%	0.50	4 000	0.06%	0.17
Total.....		3 735 000	2.21%	3.89	161 000	2.35%	0.17
TOTAL WORLD.....		168 573 000	100.00%	7.67	6 857 000	100.00%	0.31

NOTE : Telegraph service is operated by Governments, except in the United States and Canada. In connection with telephone wire, P. indicates that the telephone service is wholly or predominantly operated by private companies, G. wholly or predominantly by the Government, and P.G. by both private companies and the Government. See preceding table.

* June 30, 1937. † February 28, 1938. ‡ March 31, 1938.
 † U.S.S.R., including Siberia and Associated Republics. (Estimated)

Telephone Development of Large and Small Communities—January 1, 1938

COUNTRY	Service Operated By (See Note)	NUMBER OF TELEPHONES		TELEPHONES PER 100 POPULATION	100 POPULATION
		In Communities of 50 000 Population and Over	In Communities of less than 50 000 Population	In Communities of 50 000 Population and Over	In Communities of less than 50 000 Population
Australia**	G.	365 800	229 055	11.04	6.51
Austria	G.	218 611	63 179	9.91	1.36
Belgium†	G.	278 411	115 117	7.70	2.42
Canada	P.G.	732 289	590 505	19.83	7.95
Czecho-Slovakia*	G.	106 263	101 024	5.99	0.75
Denmark	P.	227 578	198 373	20.65	7.39
Finland	P.	64 592	107 149	12.89	3.21
France	G.	855 883	696 735	8.07	2.22
Germany†	G.	2 366 196	1 257 501	8.17	3.21
Great Britain and No. Ireland†	G.	2 200 000	885 000	8.04	4.45
Hungary	G.	113 633	35 706	4.91	0.53
Japan†	G.	903 367	401 326	3.80	0.84
Netherlands	G.	257 852	143 632	7.16	2.85
New Zealand†	G.	80 957	111 063	14.23	10.73
Norway**	P.G.	89 465	132 545	21.98	5.28
Poland	P.G.	172 401	99 899	3.71	0.33
Sweden	G.	285 573	453 125	25.87	8.75
Switzerland	G.	197 721	233 156	21.87	7.07
Union of South Africa†	G.	117 777	71 824	8.29	0.84
United States	P.	11 196 576	8 256 825	21.23	10.84

NOTE: P. indicates that the telephone service is wholly or predominantly operated by private companies, G. wholly or predominantly by the Government, and P.G. by both private companies and the Government. See first table.
 * January 1, 1937. ** June 30, 1937. † February 28, 1938. ‡ March 31, 1938.

Telephone Conversations and Telegrams—Year 1937

COUNTRY	Number of Telephone Conversations	Number of Telegrams	Total Number of Wire Communications	PER CENT OF TOTAL WIRE COMMUNICATIONS		WIRE COMMUNICATIONS PER CAPITA		Total
				Telephone Conversations	Telegrams	Telephone Conversations	Telegrams	
Australia	568 000 000	17 015 000	585 015 000	97.1	2.9	83.4	2.5	85.9
Austria	655 000 000	1 649 000	656 649 000	99.7	0.3	96.0	0.2	96.2
Belgium	316 000 000	5 861 000	321 861 000	98.2	1.8	37.9	0.7	38.6
Canada	2 613 807 000	12 441 000	2 626 248 000	99.5	0.5	236.0	1.1	237.1
Czecho-Slovakia*	285 000 000	4 018 000	289 018 000	98.6	1.4	18.7	0.3	19.0
Denmark	693 000 000	1 624 000	694 624 000	99.8	0.2	182.6	0.4	183.0
Finland	279 000 000	799 000	279 799 000	99.7	0.3	73.0	0.2	73.2
France	974 000 000	28 170 000	1 002 170 000	97.2	2.8	23.2	0.7	23.9
Germany	2 722 000 000	16 883 000	2 738 883 000	99.4	0.6	40.1	0.2	40.3
Gt. Britain and No. Ireland	2 186 000 000	58 618 000	2 244 618 000	97.4	2.6	46.4	1.2	47.6
Hungary	178 000 000	2 133 000	180 133 000	98.8	1.2	19.8	0.2	20.0
Japan	5 082 000 000	66 128 000	5 148 128 000	98.7	1.3	71.4	0.9	72.3
Netherlands	435 000 000	3 374 000	438 374 000	99.2	0.8	50.6	0.4	51.0
Norway	294 000 000	3 385 000	297 385 000	98.9	1.1	101.1	1.2	102.3
Poland	562 000 000	3 783 000	565 783 000	99.3	0.7	16.4	0.1	16.5
Sweden	1 070 000 000	4 107 000	1 074 107 000	99.6	0.4	170.5	0.7	171.2
Switzerland	294 000 000	1 754 000	295 754 000	99.4	0.6	70.2	0.4	70.6
Union of South Africa	307 000 000	7 075 000	314 075 000	97.7	2.3	31.2	0.7	31.9
United States	28 300 000 000	207 000 000	28 507 000 000	99.3	0.7	220.2	1.6	221.8

NOTE: Telephone conversations represent completed local and toll or long distance messages. Telegrams include inland and outgoing international messages.
 * Year 1936.

NOTE: There are shown, for purposes of comparison with cities in other countries, the total development of all cities in the United States in certain population groups, and the development of certain representative cities within each of such groups.
 * June 30, 1937. † February 28, 1938. ‡ March 31, 1938.
 †† International Settlement and French Concession.

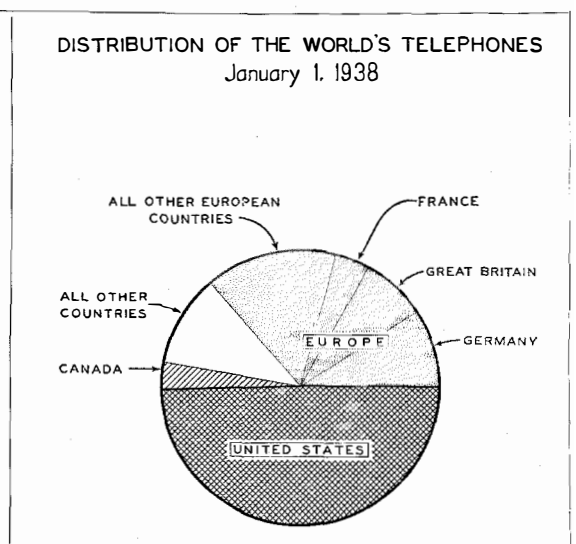
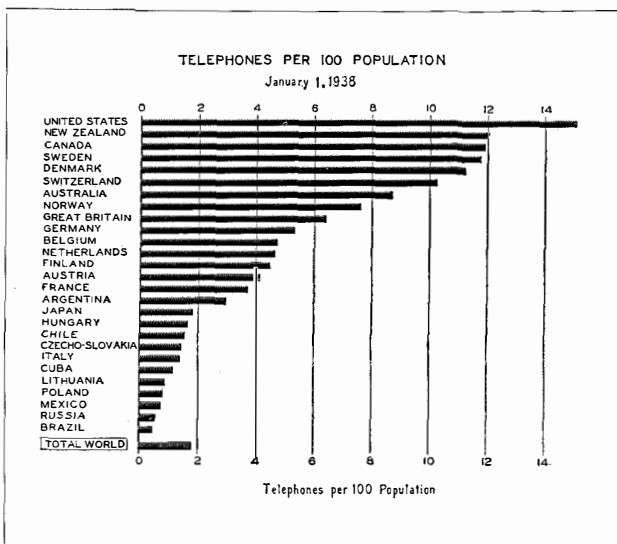

Telephone Development of Large Cities
January 1, 1938

Country and City (or Exchange Area)	Estimated Population (City or Ex- change Area)	Number of Telephones	Telephones Per 100 Population	Country and City (or Exchange Area)	Estimated Population (City or Ex- change Area)	Number of Telephones	Telephones Per 100 Population
ARGENTINA :				IRELAND (Eire) :†			
Buenos Aires.....	3 075 000	233 051	7.58	Dublin.....	477 000	22 760	4.77
AUSTRALIA :				ITALY :			
Adelaide.....	318 000	34 177	10.75	Milan.....	1 178 000	101 528	8.62
Brisbane.....	318 000	33 417	10.51	Naples.....	907 000	29 911	3.30
Melbourne.....	1 024 000	127 516	12.45	Rome.....	1 247 000	111 784	8.96
Sydney.....	1 279 000	150 005	11.73	JAPAN :†			
AUSTRIA :				Kobe.....	975 000	44 728	4.59
Graz.....	153 000	11 748	7.68	Kyoto.....	1 150 000	50 162	4.36
Vienna.....	1 878 000	192 149	10.23	Nagoya.....	1 220 000	43 674	3.58
BELGIUM :‡				Osaka.....	3 260 000	165 486	5.08
Antwerp.....	560 000	48 696	8.70	Tokio.....	6 320 000	269 565	4.27
Brussels.....	991 000	127 639	12.88	LATVIA :†			
Liege.....	433 000	29 885	6.90	Riga.....	390 000	29 310	7.52
BRAZIL :				LITHUANIA :			
Rio de Janeiro.....	1 860 000	87 609	4.71	Kaunas.....	108 000	7 906	7.32
CANADA :				MEXICO :			
Montreal.....	1 063 700	178 518	16.78	Mexico City.....	1 423 000	79 384	5.58
Ottawa.....	193 300	38 590	19.96	NETHERLANDS :			
Toronto.....	793 800	208 524	26.27	Amsterdam.....	790 000	62 348	7.89
Vancouver.....	277 700	73 219	26.37	Haarlem.....	170 000	14 080	8.28
CHILE :				Rotterdam.....	625 000	41 884	6.70
Santiago.....	843 000	35 640	4.23	The Hague.....	535 000	53 926	10.08
CHINA :				NEW ZEALAND :†			
Hong Kong.....	800 000	18 764	2.35	Auckland.....	209 000	28 530	13.65
Shanghai††.....	1 600 000	45 495	2.84	NORWAY :*			
CUBA :				Oslo.....	250 000	60 331	24.13
Havana.....	710 000	40 662	5.73	PHILIPPINE ISLANDS :			
CZECHO-SLOVAKIA :				Manila.....	450 000	22 353	4.97
Prague.....	965 000	74 586	7.73	POLAND :			
DANZIG :				Lodz.....	665 000	17 292	2.60
Free City of Danzig.....	253 000	18 666	7.38	Warsaw.....	1 261 000	81 900	6.49
DENMARK :				PORTUGAL :			
Copenhagen.....	873 000	201 987	23.14	Lisbon.....	683 000	30 476	4.46
FINLAND :				ROUMANIA :			
Helsingfors.....	290 000	46 556	16.34	Bucharest.....	800 000	39 287	4.91
FRANCE :				SWEDEN :			
Bordeaux.....	260 000	22 739	8.75	Göthenburg.....	270 000	54 097	20.04
Lille.....	200 000	18 155	9.08	Malmö.....	148 000	25 920	17.51
Lyons.....	650 000	38 764	5.96	Stockholm.....	458 000	165 248	36.08
Marseilles.....	915 000	37 801	4.13	SWITZERLAND :			
Paris.....	2 850 000	435 832	15.29	Basel.....	154 000	36 773	23.88
GERMANY :†				Berne.....	116 000	28 889	24.90
Berlin.....	4 307 000	574 367	13.34	Geneva.....	150 000	29 938	19.96
Breslau.....	624 000	47 011	7.53	Zurich.....	282 000	66 368	23.53
Cologne.....	768 000	72 319	9.42	UNITED STATES :			
Dresden.....	821 000	72 144	8.79	(See Note)			
Dortmund.....	577 000	27 385	4.75	New York.....	7 284 000	1 623 117	22.28
Essen.....	672 000	34 931	5.20	Chicago.....	3 520 000	945 598	26.86
Frankfort-on-Main.....	650 000	67 114	10.33	Los Angeles.....	1 390 000	423 766	30.49
Hamburg-Altona.....	1 714 000	180 411	10.53	Pittsburgh.....	1 040 000	216 745	20.84
Leipzig.....	762 000	71 523	9.39	Total 10 cities over			
Munich.....	848 000	92 878	10.95	1 000 000 Population			
GREAT BRITAIN AND				Milwaukee.....	790 000	155 500	19.68
NO. IRELAND :†				San Francisco.....	721 000	275 204	38.17
Belfast.....	415 000	22 308	5.38	Washington.....	584 700	226 957	38.82
Birmingham.....	1 260 000	75 960	6.03	Minneapolis.....	515 000	141 156	27.41
Bristol.....	446 000	29 249	6.56	Total 10 cities with			
Edinburgh.....	460 000	42 923	9.33	500 000 to 1 000 000			
Glasgow.....	1 140 000	68 784	6.03	Population.....	6 703 900	1 532 146	22.85
Hull.....	358 000	23 488	6.56	Seattle.....	423 200	122 884	29.04
Leeds.....	562 000	34 648	6.17	Denver.....	317 000	101 277	31.95
Liverpool.....	1 260 000	76 424	6.07	Hartford.....	243 300	62 845	25.83
London—				Omaha.....	236 100	65 974	27.94
(City and County of				Total 34 cities with			
London)	4 057 000	696 808	17.18	200 000 to 500 000			
Manchester.....	1 005 000	66 560	6.62	Population.....	10 580 200	2 150 960	20.33
Newcastle.....	477 000	26 526	5.56	Total 54 cities with			
Sheffield.....	517 000	26 924	5.21	more than 200 000			
HAWAII :				Population.....	39 814 900	8 749 227	21.97
Honolulu.....	150 000	20 914	13.94				
HUNGARY :							
Budapest.....	1 606 000	100 677	6.27				
Szeged.....	140 000	2 441	1.74				

NOTE: There are shown, for purposes of comparison with cities in other countries, the total development of all cities in the United States in certain population groups, and the development of certain representative cities within each of such groups.
* June 30, 1937. † February 28, 1938. ‡ March 31, 1938.
†† International Settlement and French Concession.

TELEPHONES PER 100 POPULATION
OF LARGE CITIES

January 1, 1938

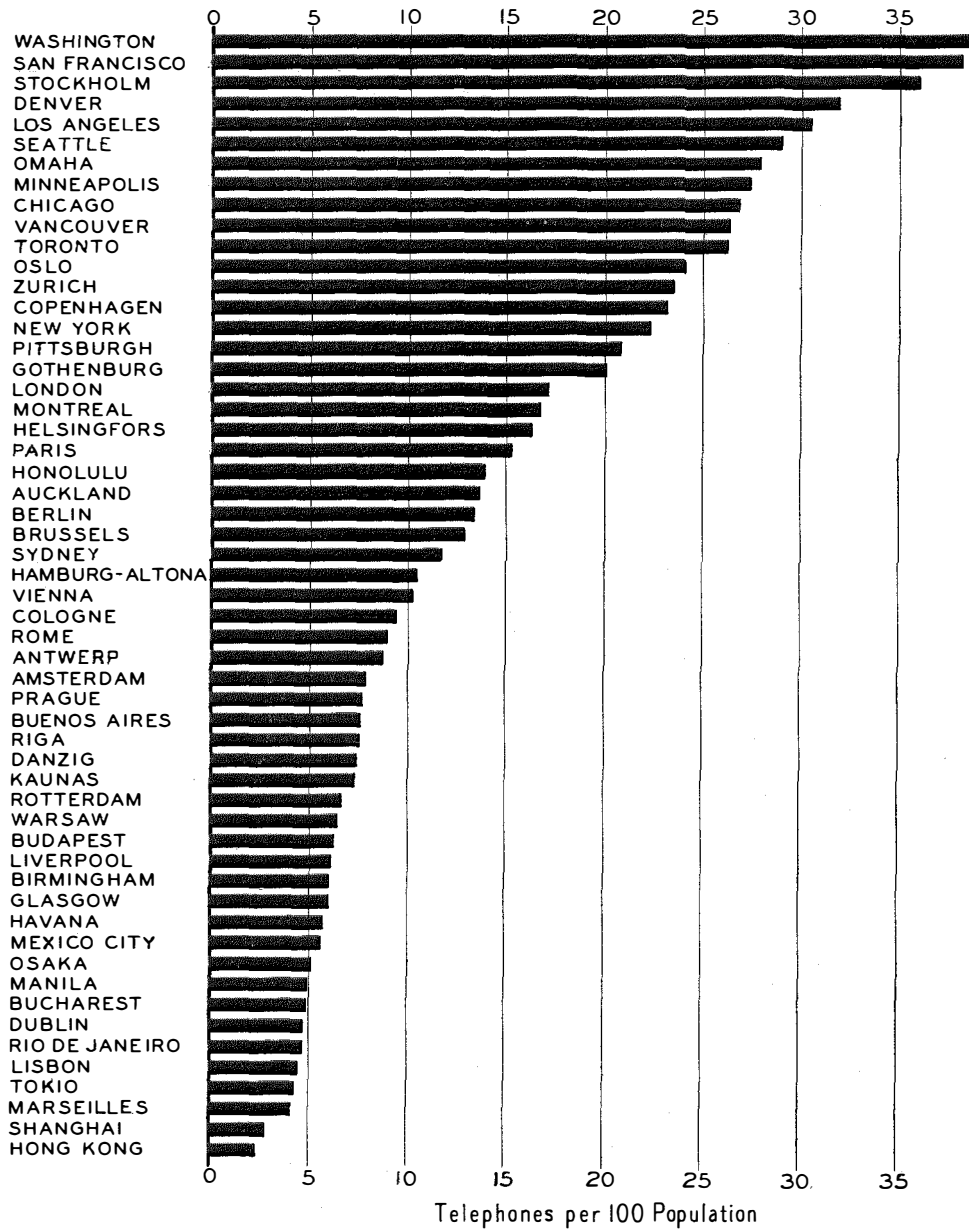

Recent Telecommunication Developments of Interest

PM-5 Portable Radio Set.—The Bell Telephone Manufacturing Company, Antwerp, has designed a one load portable radio telephone and telegraph station intended for short distance communication.

The complete set is contained in a duralumin box which can very easily be carried on the back of one person. The total weight does not exceed 20 kg and the approximate dimensions are 350 × 300 × 375 mm. It is especially designed to withstand the severe conditions encountered in field service.

The antenna consists of a vertical rod 3 m high composed of 11 sections.

The frequency of the transmitter and the receiver is controlled by one large lever moving

in front of a circular scale directly calibrated in kc/s. The transmitter and the receiver are therefore always tuned on the same frequency. The generally used frequency range extends from 4.3 Mc/s to 7.5 Mc/s (40 to 70 m), but the set can be furnished for operation over any range of the same wavelength ratio between 25 and 1.5 Mc/s (12 to 200 m). Quick change-over between two selected frequencies is provided.

The transmitter consists of an electron-coupled master oscillator followed by a power amplifier. The antenna is tuned by means of a single knob without any tap choosing switch. Its power varies between 0.3 and 0.4 W according to the frequency. A push-pull low frequency stage modulates the power amplifier on both plate and screen.

The receiver is of the superheterodyne type. Reception of CW telegraphy is obtained by oscillating the second detector. A vernier is provided and permits fine receiver tuning without altering the tuning of the transmitter. The sensitivity of the receiver is very good, 2 microvolts modulated 30% at 400 p : s giving an output of at least 1 mW.

The selectivity is such that a signal 10 kc off tune is attenuated by 32 db. The image ratio is better than 50 db.

The power supply consists of dry cell batteries :

144 V for the H.T.

3 V for the L.T.

18 V for the bias voltages.

The only controls, located on the front panel, are the wavelength change controls and the heating voltage regulator. All other controls are on the handpiece so that one man can operate the set while marching. These controls are : (a) On-off switch ; (b) Send-receive switch ; and (c) Volume control of the receiver.

• • •
Bellton Chimes.—The Bell Telephone Manufacturing Company, Antwerp, recently

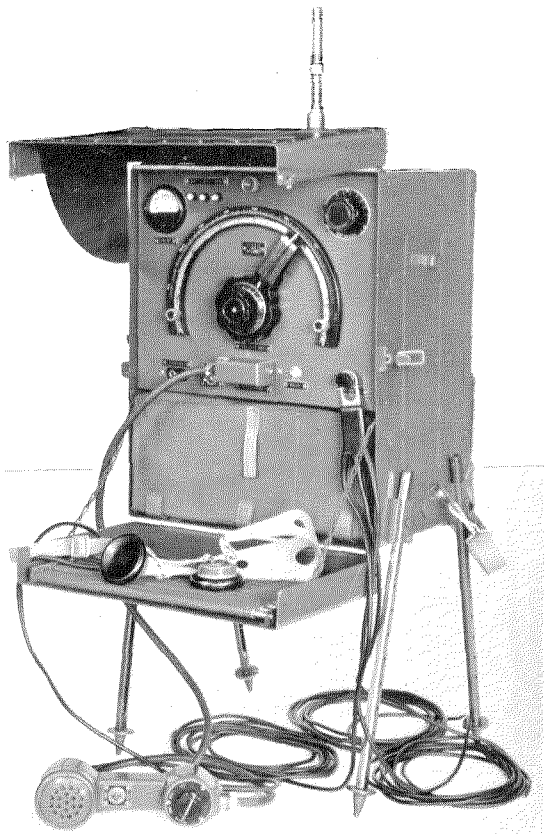

began manufacture of a line of electric signalling chimes. These signalling devices have the outstanding feature of emitting a mellow single or double note instead of the usual harsh buzz or disagreeable clamour of the ordinary buzzer or electric bell. They are attractive in design and may be installed equally well in homes, offices or factories.

Three types are available :

The "Baby" is a compact single-stroke chime suitable for lifts or for industrial or office applications, where code signalling systems are desirable.

The "Senior" normally emits a deep two-tone chime, but may also be wired to give a single note from a second signalling position. This model may be used as a door chime in the home, or as a secretary's or receptionist's signal in offices.

The "De Luxe" is a more elaborate chime fitted with a pair of long chromium-plated tubes. It gives a clear penetrating two-tone chime suitable for use as a door signal in large homes or for installation in schools, laboratories, hospitals, etc.

Any of the Bellton models may be substituted for ordinary bells or buzzers without change of wiring, or they may be arranged to operate directly from 110 or 220-volt D.C. mains, or, by means of a special transformer, from A.C. mains.

• • •

Telecommunications Exhibition.—At the Telecommunications Exhibition, organized by the Department of Posts and Telegraphs (Argentina) during the period of the International Postal Conference (Buenos Aires, April,

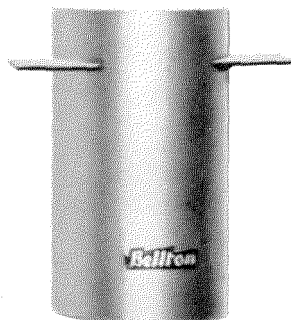

"Baby" Bellton Chimes.

1939), items featured by the Compañía Standard Electric Argentina included the following: a Creed Printer receiving bulletins from one of the news agencies, a Western Electric Police Radio Equipment (to be installed in Cordoba), a W.E. 100 kW Valve of the type used in the Buenos Aires Municipal Broadcasting Station, and a Mix and Genest Master Clock (to be installed in the Durand Hospital, Buenos Aires).

Other participating Companies in the International Telephone and Telegraph Group included the United River Plate Telephone Company, Limited, which displayed switchboards, carrier equipment, etc., in actual operation; All America Cables and Radio, Inc.; Compañía Internacional de Radio (Argentina) and Sociedad Anónima Radio Argentina.

Licensee Companies

A.B. STANDARD RADIOFABRIK.....	<i>Ulusunda (Sweden)</i>
BELL TELEPHONE MANUFACTURING COMPANY.....	<i>Antwerp</i>
<i>Branches : Brussels</i>	
BELL TELEPHONE MANUFACTURING COMPANY.....	<i>Berne</i>
BELL TELEPHONE MANUFACTURING COMPANY.....	<i>The Hague</i>
CHINA ELECTRIC COMPANY, LIMITED.....	<i>Shanghai</i>
<i>Branches : Hongkong, Tientsin, Canton, Kunming.</i>	
COMPAGNIE DES TÉLÉPHONES THOMSON-HOUSTON.....	<i>Paris</i>
COMPAÑÍA RADIO AEREA MARITIMA ESPAÑOLA.....	<i>Madrid</i>
COMPAÑÍA STANDARD ELECTRIC ARGENTINA.....	<i>Buenos Aires</i>
CREED AND COMPANY, LIMITED.....	<i>Croydon (England)</i>
FABBRICA APPARECCHIATURE PER COMUNICAZIONE ELETTRICHE.....	<i>Milan</i>
<i>Branch : Rome.</i>	
INTERNATIONAL MARINE RADIO COMPANY, LIMITED.....	<i>London</i>
JUGOSLAVIAN STANDARD ELECTRIC COMPANY, LIMITED.....	<i>Belgrade</i>
KOLSTER-BRANDES, LIMITED.....	<i>Sidcup (England)</i>
LE MATÉRIEL TÉLÉPHONIQUE.....	<i>Paris</i>
C. LORENZ, A.G.....	<i>Berlin-Tempelhof</i>
MIX & GENEST AKTIENGESELLSCHAFT.....	<i>Berlin-Schöneberg</i>
NIPPON DENKI KABUSHIKI KAISHA.....	<i>Tokyo</i>
<i>Branches : Osaka ; Dalny (Dairen, Manchuria) ; Taihoku (Formosa).</i>	
SOCIÉTÉ ANONYME LES TÉLÉIMPRIMEURS.....	<i>Paris</i>
STANDARD ELECTRIC AKTIESELSKAB.....	<i>Copenhagen</i>
STANDARD ELECTRIC COMPANY W POLSCE SKA Z O. O.....	<i>Warsaw</i>
STANDARD ELECTRIC DOMS A SPOL.....	<i>Praha</i>
<i>Branch : Bratislava.</i>	
STANDARD ELECTRICA.....	<i>Lisbon</i>
STANDARD ELÉCTRICA, S.A.....	<i>Madrid</i>
<i>Branches : Barcelona, Santander.</i>	
STANDARD ELECTRICA, S.A.....	<i>Rio de Janeiro</i>
STANDARD FABRICA DE TELEFOANE SI RADIO, S.A.....	<i>Bucharest</i>
STANDARD TELEFON OG KABELFABRIK A/S.....	<i>Oslo</i>
STANDARD TÉLÉPHONE ET RADIO, S.A. Zürich.....	<i>Zürich</i>
STANDARD TELEPHONES AND CABLES, LIMITED.....	<i>London</i>
<i>Branches : Glasgow, Leeds, Dublin, Cairo, Pretoria, Calcutta.</i>	
STANDARD TELEPHONES AND CABLES (PTY.), LIMITED.....	<i>Sydney</i>
<i>Branches : Melbourne ; Wellington, New Zealand.</i>	
STANDARD VILLAMOSSÁGI RÉSZVÉNY TÁRSASÁG.....	<i>Budapest</i>
SÜDDEUTSCHE APPARATEFABRIK GESELLSCHAFT m.b.h.....	<i>Nürnberg</i>
SUMITOMO ELECTRIC WIRE & CABLE WORKS, LIMITED.....	<i>Osaka</i>
TELEFONGYÁR r.t.....	<i>Budapest</i>
VEREINIGTE TELEPHON- UND TELEGRAPHENFABRIKS AKTIEN-GESELLSCHAFT, CZEIJA, NISSEL & CO.....	<i>Vienna</i>

Sales Offices and Agencies Throughout the World.